

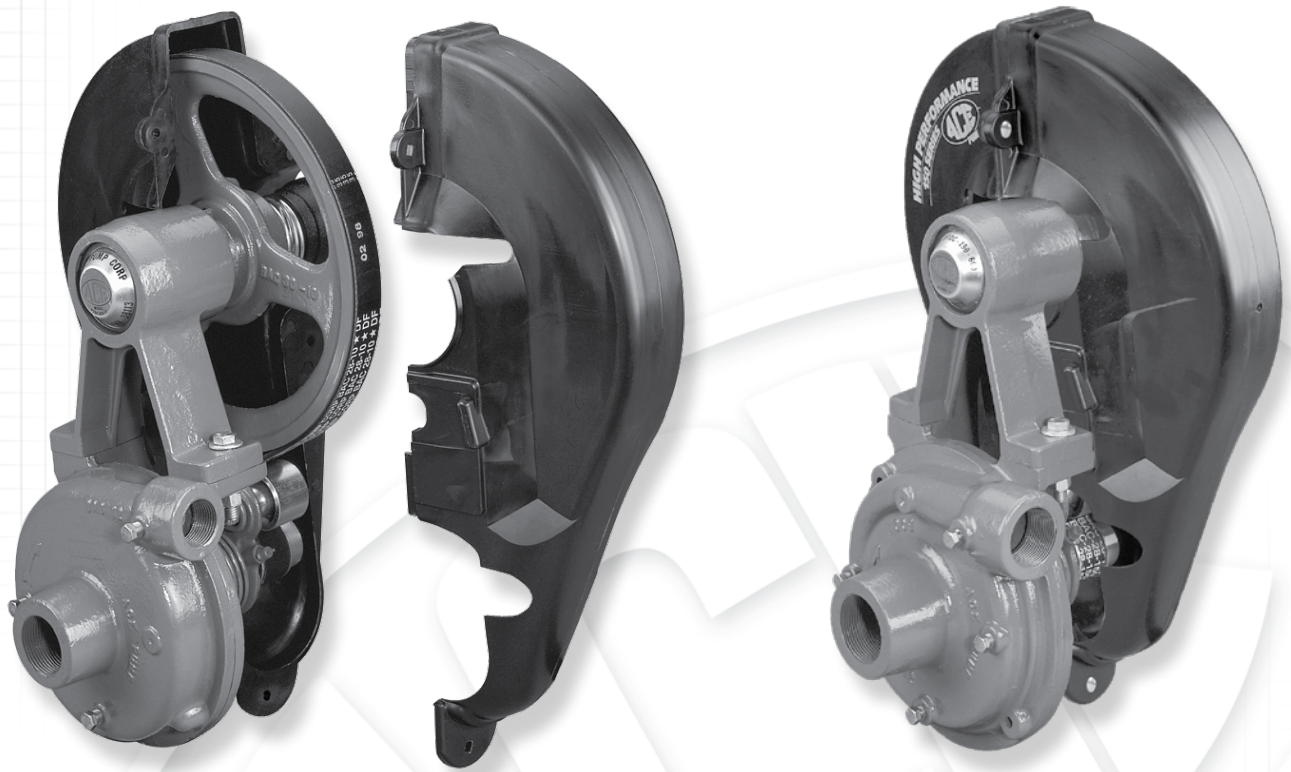

INSTRUCTION MANUAL



PTO DRIVEN CENTRIFUGAL PUMPS

TABLE OF CONTENTS

Warnings	1
PTOC Pump Features	1
Plumbing Diagram	2
Sprayer Plumbing Suggestions	2
Pump Mounting	3
Mechanical Shaft Seals	3
Installation Instructions	4
Maintenance and Storage	5
Pump Repair Instructions	6
Pump Repair Kits	8
Trouble Shooting	8
Warranty	9

Note: Pump performance data, dimensions, and parts listings are available on individual pump specification sheets and are not included in this manual. The specification sheets may be downloaded from the Product Literature page at AcePumps.com or call 800-843-2293 to request a copy.

WARNINGS

BELT AND SHAFT GUARD MUST BE INSTALLED



The belt, pulleys, idler, and PTO driveline on these pumps are external moving components which present a danger to the operator and personnel in the area if not properly guarded and operated. Prior to using any belt driven pump, ensure the belt and shaft guards are installed and functioning properly. While operating the pump, keep all articles (hands, fingers, clothing, hair, etc.) away all moving parts and pinch points.

TIE DOWN

See “Tie Down Pump” section on page 5 for instructions. Failure to follow these instructions may result in physical injury or damage to the tractor and pump.

HANDLE CHEMICAL PRODUCTS SAFELY

Direct exposure to hazardous chemicals may cause serious injury. Potentially hazardous chemicals used with Ace pumps are grease, fertilizer, and chemicals. A Material Safety Data Sheet (MSDS) provides specific details on chemical products: physical and health hazards, safety procedures, and emergency response techniques. Always review the MSDS before starting any job using a hazardous chemical.

PTO DRIVEN PUMP FEATURES

Easily Maintained - Model PTOC pumps are easy to operate and maintain. Belts can be replaced in the field with minimum downtime. Maintenance features also include sealed ball bearings and a readily replaceable mechanical seal.

Spring Loaded Idler - The idler maintains proper belt tension which minimizes the load on the pump bearings. More importantly, the idler helps absorb the shock of PTO engagement that can destroy belts or gears.

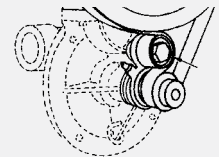

Belt Guard - The belt guard provides complete coverage of the pulleys, shafts, and belt.

Roundup® Ready - All PTO driven pumps are equipped with a stainless steel shaft and wear ring for excellent corrosion resistance. ®Roundup is a registered trademark of Monsanto Company.

Consult these Ace Product Updates for more information:

Update 5 - BAC-31 Bearing

Update 7 - Belt Guard Kit

Update 10 - Drive Shaft Changes

Product Updates can be found on the Product Literature page at AcePumps.com.

Suction x Discharge Connections:

PTOC Models - 1 1/4" x 1"

PTOC-150 Models - 1 1/2" x 1 1/4"

PLUMBING DIAGRAM

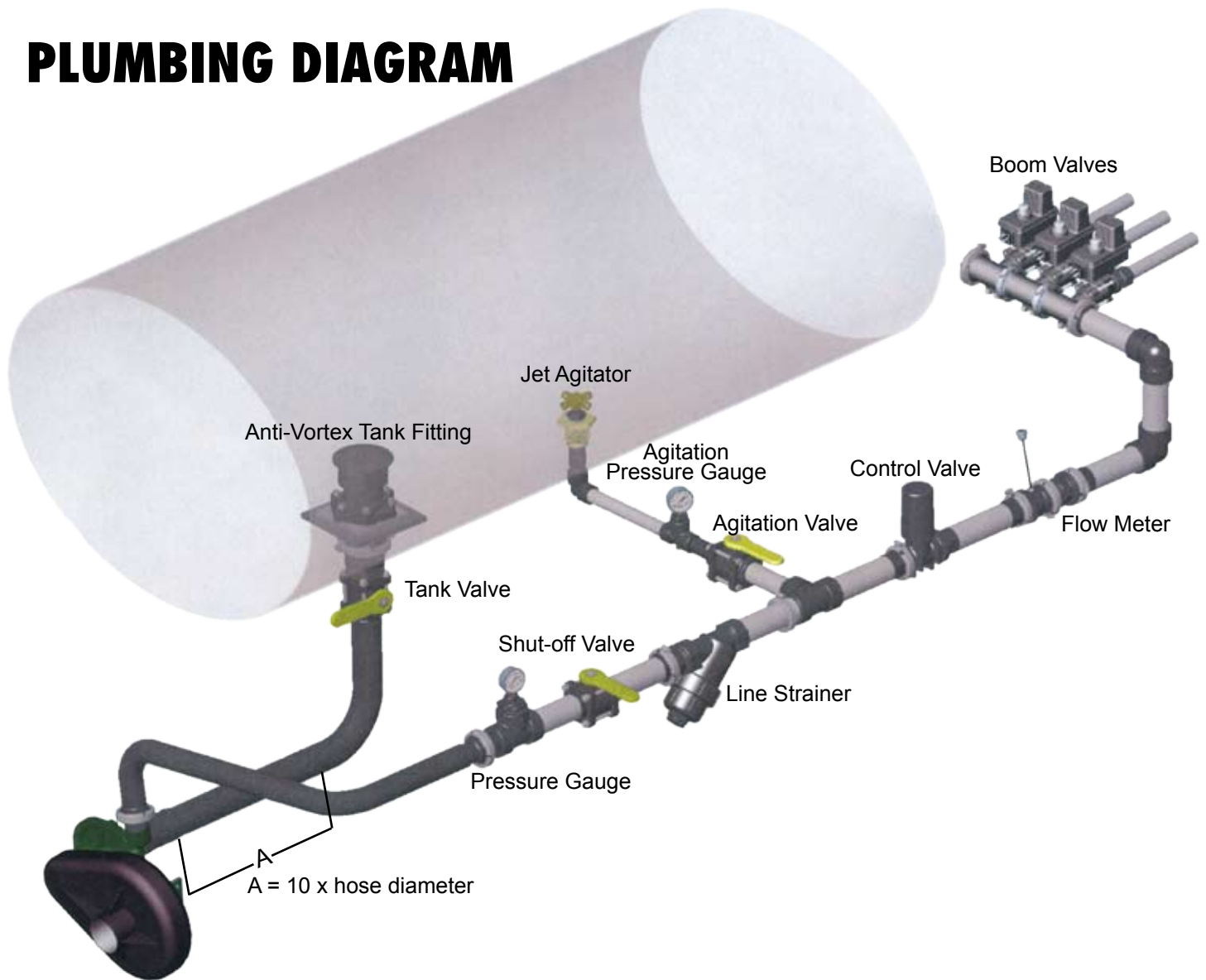

SPRAYER PLUMBING SUGGESTIONS

The primary goal when plumbing a sprayer pump is to route liquid from the pump to the spray boom with minimum restriction. Minimizing restrictions is necessary for achieving the pump's maximum rated capacity.

1. Hoses should be the same size as the pump's suction and discharge port. Increasing the suction hose diameter by one size will improve the pumps performance.
2. A minimum number of elbows, fittings, and valves should be used to reduce pressure losses.
3. Plumb a straight section of hose leading into the suction port equal to 10 times the hose inside diameter. (i.e. 1-1/2" hose = 15" of straight hose)
4. Use spray control valves and a flowmeter that are the same size as the discharge port to prevent flow restriction.

Following these guidelines is necessary for delivering the highest pressure to the boom.

PUMP MOUNTING

The following are basic guidelines for proper pump mounting:

1. Always check to see that the pump can be turned by hand before mounting.
2. The pump should be mounted below the tank(s) to allow gravity to naturally fill the pump with liquid.
3. The volute should be oriented with the discharge port pointing up or across the top of the pump which allows air to rise out of the pump.
4. A petcock valve can be installed in the top most pipe plug hole to allow air to be bled off each time the tanks are filled.
5. Another option is to install a 1/4" air bleed line from the top most pipe plug hole to the sprayer tank. This will continually bleed air from the pump housing.
6. If the pump must be located above the liquid level, a foot valve should be installed to maintain the pump's prime.

PTO driven centrifugal pumps are straight centrifugals and must be primed prior to operation. The word "primed" means the pump must be completely full of water and any trapped air vented before a centrifugal pump can operate. Following the pump mounting guidelines will insure proper priming of the pump and avoid premature seal failure.

MECHANICAL SHAFT SEALS

Mechanical seals have two polished faces which run against one another forming a barrier preventing solution from leaking. A small quantity of liquid crosses the faces and is necessary to lubricate and remove heat from the seal faces. The two most common causes of seal failure are:

1) Abrasive Wear - The carbon seal face is scratched by harder material crossing the face. Damage to the seal by harder materials can be caused by abrasive solution materials, rust, or corrosion near the seal, precipitates which come out of solution when heated, and residue between the seal faces when a pump is shut off and not flushed out. This type of seal failure can be minimized by flushing the pump with water after use and storing the pump filled with antifreeze to prevent corrosion and freezing.

Note: In tough applications where the standard carbon seal face is scratched or quickly worn, the **BAC-7SC** seal with extra hard silicon carbide faces is recommended.

2) Thermal Shock - The seal face is cracked by cool liquid contacting a hot seal. There is no liquid to lubricate or remove heat from the seal faces when a pump runs dry. The seal heats up rapidly to a temperature that causes damage to the seal components. The resulting thermal shock creates radial cracks in the white ceramic face and the heat may melt rubber components.

Consult Ace Product Update 2- Mechanical Seals for additional information. Product Updates can be found on the Product Literature page at AcePumps.com.



INSTALLATION INSTRUCTIONS

CHECK BELT ALIGNMENT

All pumps are factory tested for leakage and belt alignment. It is possible for belt alignment to shift during shipment. Check belt alignment prior to installing pump on tractor.

Alignment may be checked by rotating the large pulley back and forth while observing belt tracking at the idler roller (see photo). If you see a belt shift on the roller when the direction of rotation changes, the pulleys need to be realigned.

Caution: Keep hands away from pinch points while checking alignment.

Alignment instructions:

1. Loosen two set screws on the small pulley BAC-29.
2. Move small pulley along pump shaft until belt does not shift when large pulley is rotated back and forth.
3. Tighten set screws on small pulley.

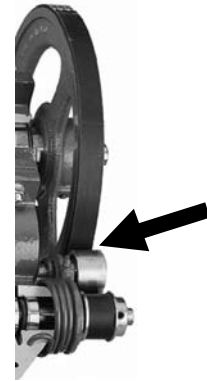

CONNECT TO PTO

Follow the connection instructions for the type of coupler on your pump:

-B (base mount on implement with 1" stub shaft)

Connection Instructions:

1. To minimize stress and vibration on the pump and driveline:
 - a. The hitch pin must be centered between pump and tractor PTO shaft. See diagram: $L_1 = L_2$
 - b. The distance from the ground to PTO shaft should be equal to the distance from the ground to the pump stub shaft. See diagram: $H_1 = H_2$
 - c. If either of the above is not possible, a constant velocity (CV) driveline is recommended.
2. Slide driveline with key onto pump stub shaft.
3. Install a 5/16" bolt through cross hole and secure with a washer and nut.
4. Attach other end of driveline to your tractor PTO as instructed by driveline manufacturer.

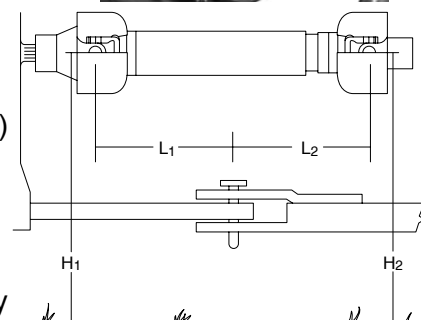

-6SP (1-3/8" 6 spline connection with set screws)

Connection Instructions:

1. Loosen 3/8" jam nuts and back set screws out.
2. Slide coupler onto tractor PTO shaft and align set screws with retaining groove on PTO shaft.
3. Tighten set screws with a screwdriver and lock jam nuts.
4. Pull against large pump pulley to verify pump is securely attached.



(Continued on next page)

-6SPQC (1-3/8" 6 spline connection with quick coupler)

Connection Instructions:

1. Pull locking collar toward large pulley to release locking balls.
2. Slide coupler onto tractor PTO shaft.
3. Release locking collar and verify that coupling balls engage retaining groove of tractor PTO shaft.
4. Pull against large pump pulley to verify that pump is securely attached.



-20SP & -21SP (20 and 21 spline connection with locking collar and set screws)

Connection Instructions:

1. Loosen 3/8" jam nuts and back set screws out.
2. Slide coupler onto tractor PTO shaft and align set screws with retaining groove on PTO shaft.
3. Tighten locking collar 5/16" allen head set screw to center coupler on tractor PTO shaft.
4. Tighten set screws with a screwdriver and tighten jam nuts.
5. Pull against large pump pulley to verify that pump is securely attached.

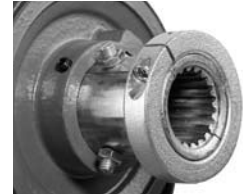

TIE DOWN PUMP

Ace PTO driven centrifugal pumps may be swung to the bottom, top, or either side of the tractor PTO shaft in order to fit a particular tractor. The pump may be operated in all of these positions. **IMPORTANT:** Remember the discharge port should always be at the top to aid in priming.

It is necessary to anchor the pump to prevent it from rotating with the tractor PTO shaft:

1. Connect one end of a torque chain to the shackle on pump casting (BAC-14).
2. Connect other end of torque chain to a stationary object on tractor. The chain should be connected in the same plane as the shackle to prevent binding with the PTO shaft.

CAUTION: Do not fasten pump rigidly in position with torque chain.

INSTALL BELT GUARD

WARNING: Never operate the pump without the belt guard installed.

Installation Instructions:

1. Insert rectangular nut BGK-101-1 (1/4" x 1-1/2" x 3-1/2") into slot on one half of belt guard.
2. Close two halves of guard together around pump. Verify that rectangular nut is inserted into slots on both halves of guard.
3. Insert four carriage bolts through mounting holes from right to left and secure with wing nuts.
4. Insert cap screw BGK-105-1 through hole in rectangular washer BGK-101 (1/4" x 1-1/2" x 2").
5. Thread cap screw BGK-105-1 into rectangular nut BGK-101-1 and tighten.

MAINTENANCE AND STORAGE

1. Grease the BAC-13 idler arm daily through the zerk fitting. **Caution:** Do not allow excess grease to accumulate on the belt.
2. Ace pumps are equipped with factory lubricated bearings and require no further maintenance.
3. If danger of freezing exists, drain pump by removing bottom volute pipe plug.
4. Neutralize chemicals and flush pump after each use to prevent corrosion.
5. Pump storage:
 - A. Flush out pump with clean water and neutralize chemicals.
 - B. Fill pump with recreational vehicle antifreeze to protect from corrosion and freezing.

PUMP REPAIR INSTRUCTIONS

Most PTOC pump repairs can be completed without complete disassembly of the pump. Determine the repair you need to perform and reference the specific sections:

Belt-Guard Removal

1. Loosen and remove cap screw BGK-105-1 and remove rectangular washer BGK-101.
2. Remove four wing-nuts and carriage bolts from belt guard.
3. Separate two halves of guard and remove. Do not lose the BGK-101-1 rectangular nut.

Belt Removal

4. Use a 15/16" socket with long pull handle on the idler bolt to release belt tension then remove belt.

Note: Keep fingers and hands away from pinch points at pulleys and idler.

Belt installation tip: Use the tension release procedure above for belt installation. Rolling a belt across the pulley grooves will damage the belt.

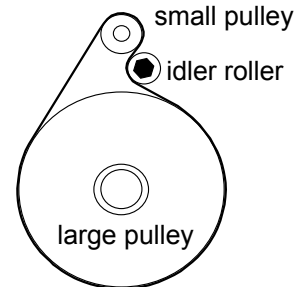

Separate Pump and PTO Drive

5. Remove two 3/8" bolts, lock washers, flat washers, and nuts that hold BAC-14 and BAC-15 castings together. **Note:** Pumps made since 2000 include alignment pins inside the bolt holes for precise alignment of the castings. You may need to tap the pins out to separate castings.

Idler Arm Removal

6. Loosen two set screws on small pulley.
7. Use a gear puller or two large screw drivers to remove pulley and key from pump shaft.
8. Remove BAC-36 snap ring and slide off idler assembly.
9. Remove roller assembly and spacer by loosening 5/8" capscrew from BAC-13 idler arm.
10. If bearing needs replacing, remove 41070 snap ring and press bearing out of tire.
11. Remove spring.

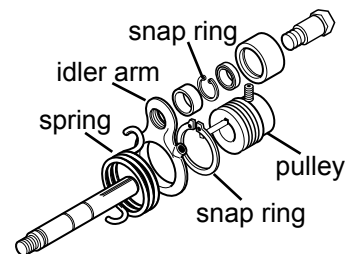

Steps 6-11

Pump Seal Replacement

12. Remove four 3/8" cap screws from mounting frame.
13. Remove volute and O-ring.
14. Remove impeller.
 - a. PTOC models: Unscrew impeller from pump shaft by turning clockwise (left hand threads).
 - b. PTOC-150 models: Remove 3/8" lock nut, washer, and key from shaft.

Caution: Excess torque may damage plastic impellers. A flat file may be inserted into the impeller vane to help with removal and spread force over a wider area.

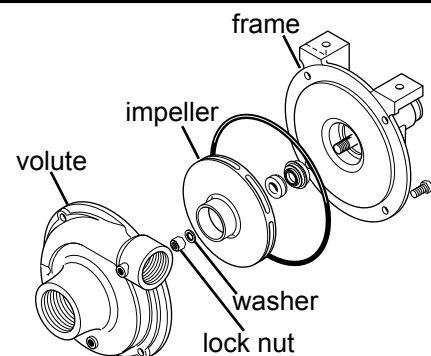

Steps 11-17

(Continued on next page)

15. Remove rotating seal member.
16. Remove stationary seal member. Use a screw driver in vent slot of BAC-14 frame to pry out.
17. Remove O-ring from shaft groove.

Seal Installation:

1. Verify that BAC-54 rubber slinger is on shaft behind seal and in front bearing. Replace if damaged. Note: The slinger prevents liquid contact with the bearings.
2. Clean old sealant from mounting frame seal bore.
3. Install new O-ring in shaft groove.
4. Apply non-hardening Type 2 Permatex or similar under stationary seal flange.
5. Place stationary portion of seal over shaft and press into seal bore cavity. Use a 1-3/8" ID pipe or PTO adapter to press seal flange evenly on all sides.
6. Install rotating portion of seal over shaft and O-ring by hand. The two polished seal faces should face each other. Avoid contacting the polished seal faces.
7. Apply anti seize compound to shaft threads or impeller seat area on shaft and key.
8. Reinstall impeller.
9. Reinstall volute.

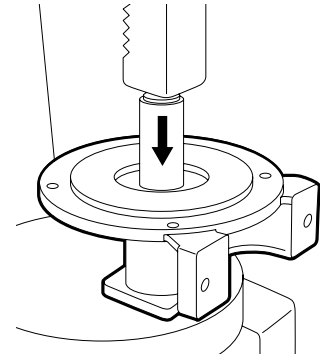

Step 5

Pump Bearing Replacement

18. Remove rear snap ring from mounting frame.
19. Press shaft/bearing assembly out of frame from impeller end.
20. Press bearings off shaft.
21. Remove forward internal bearing snap ring.

Bearing installation tip: When installing new bearings, press the inner and outer races of the bearing equally to prevent pre-loading and premature failure.

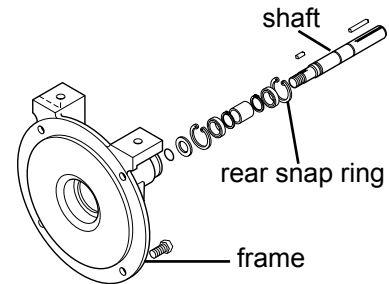

Steps 18-21

PTO Drive Assembly Repair

Note: A press is required to service this assembly.

22. Remove PTO connector from shaft:
 - 20SP & -21SP Loosen allen head screw and slide locking collar from shaft. Loosen jam nuts and remove with set screws.
 - 6SP Loosen jam nuts and remove with set screws.
 - 6SPQC Press collar toward large pulley and pop out balls. Remove the retainer sleeve and spring.
23. Loosen two 3/8" set screws on the large pulley wrench.
 - Note:** On -B model pumps remove bolt and nut from large pulley hub.
24. Press shaft out of the BAC-30 pulley and remove key.
25. Remove BAC-34 split-locking ring and name plate/dust cover.
26. Remove BAC-35 snap ring.
27. Press shaft and bearings out of bearing housing.
28. Remove internal split-lock ring from inside bearing housing.
29. Press bearings off of shaft.

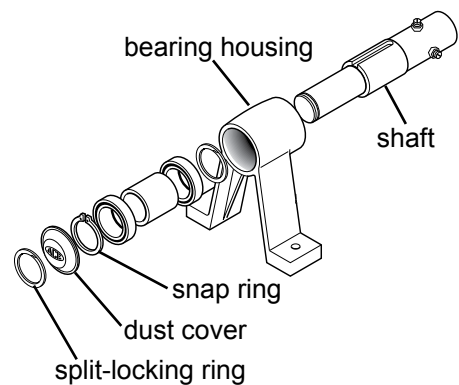

Steps 22-29

PUMP REPAIR KITS

Ace RK-PTOC pump repair kits include a belt, mechanical seal, and O-rings. Pump only repair kits do not include the belt. Pumps manufactured after January 1996 and all PTOC-150 pumps use an O-ring for the volute seal. PTOC (1-1/4" x 1") pumps manufactured prior to 1996 require a gasket volute seal (BAC-4) which is not included in repair kits. **Note:** Do not use both the O-ring and gasket.

Pump Model	Standard Seal BAC-7V	Severe Duty Seal BAC-7SC
PTOC-600 Series	RK-PTOC-600	◆
PTOC-1000 Series	RK-PTOC-1000	◆
PTOC-150-600 Series	RK-PTOC-150-600	◆
PTOC-150-1000 Series	RK-PTOC-150-1000	◆
PTOC Series PUMP ONLY	RK-FMC	RK-FMCSC
PTOC-150 Series PUMP ONLY	RK-FMC-150	RK-FMCSC-150

◆ Purchase pump only seal kit and belt separately.

TROUBLESHOOTING

WILL NOT PUMP LIQUID

There are several operating conditions which must be met before a centrifugal pump can pump liquid. If the shaft is not turning, check the first step. If the shaft is turning, go to the second step.

First, the impeller, shaft, and belt pulley must turn freely. Corrosion can form between the impeller and the volute or in the seal area. With the tractor PTO disconnected, attach vice grip pliers to the BAC-6 shaft end opposite the impeller and turn to see if the impeller turns freely.

Second, the pump must be primed. The pump will not operate unless the volute cavity is completely full of liquid when started. Remove the top pipe plug on the volute to verify that only liquid comes out. Refer to PUMP MOUNTING section on page three.

WILL NOT DEVELOP PRESSURE

There are several factors which may contribute to a pump's inability to develop pressure.

They are: 1) insufficient shaft speed; 2) restrictions in the plumbing; 3) internal leakage in the pump.

Insufficient shaft speed: The pressure created by a centrifugal pump is a function of the pump shaft speed. The shaft speed is determined by the tractor PTO or engine speed. Increase the tractor engine or PTO speed. Check the idler arm to verify that movement is not restricted. Grease the idler arm regularly to prevent seizure of the idler arm.

Restrictions in the plumbing: For every length of hose, valve, strainer, and fitting between the pump and the boom, there is a loss of pressure. Check for clogged strainers, collapsed or leaking hoses, standard port valves, and undersized plumbing.

Internal leakage in pump: In centrifugal pumps, there is a close fit where the eye of the impeller fits into the inlet port of the volute. This close fit seals the low pressure suction liquid from the high pressure liquid inside the pump. If either the impeller or volute are worn, then the pump will not develop pressure because liquid pressure leaks through this area. If there is significant play when the eye of the impeller fits into the inlet port of the volute, replace the impeller and/or volute.

BELT BREAKS OR COMES OFF

A belt coming off is typically an indication of restricted idler movement or severe belt misalignment. Check the idler arm to verify that movement is not restricted. Grease the idler arm regularly to prevent seizure of the idler arm.

WORN BELT

Belt wear on one side indicates that the pulleys are misaligned. All pumps are aligned and tested prior to leaving the factory. Belt alignment can change in shipment due to rough handling. See "Check Belt Alignment" section on page 4 to properly adjust the pulley alignment.



Typical Belt Wear

SEAL LEAKS

Refer to the section titled "MECHANICAL SHAFT SEALS" on page 3 for information on shaft seal leak causes and prevention.

BEARING NOISE OR EXCESSIVE HEAT

Replace bearings by following the instructions on page 7.

STANDARD WARRANTY

Ace pumps and valves are guaranteed against defects in material and workmanship for a period of one year from date of installation. Products or parts found to be defective upon inspection at the factory will be repaired or replaced at our discretion.

Ace Pump Corporation shall not be held liable for damages caused by abuse or misuse of the product or parts. No claim for labor in repairing or replacing such products will be allowed nor will loss of time or inconvenience be considered warranty obligations.

IMPORTANT: Pumps or valves returned for warranty consideration which are tested and found to perform within specifications are subject to an inspection charge.

PLEASE NOTE EXCEPTIONS

1. All seals are covered against defects in materials or workmanship. Seal failures resulting from application related conditions are not covered. Most seal failures are due to application conditions such as: (1) abrasive solution scratching the polished seal faces; (2) chemical attack on elastomer or glue; (3) thermal shock from running pump dry or improper priming; (4) failure to flush chemical from pump after use.
2. Gasoline engines are covered by the engine manufacturer's warranty. Engines submitted for warranty consideration should be returned to the nearest authorized engine repair station. **DO NOT RETURN ENGINE TO ACE PUMP CORPORATION.** If unable to locate nearest engine repair station, consult Ace for referral.
3. On Ace belt driven centrifugal pumps, belt alignment is not to be considered as covered by warranty. Misalignment can occur in transit and is easily corrected at point of installation.
4. Repair requests under the above categories will not be considered warranty, and current repair and transportation charges will apply.

PROCEDURE

To return a pump, valve, or part for warranty consideration, please call Ace Pump and request a Returned Goods Authorization (RGA) number (800-843-2293). Please request one RGA number for each pump or valve. Provide the part number of the item being returned along with the reason for return. Be specific when describing the nature of the defect. Include this information in the box along with a customer contact name, phone number, and return address. Ship pump prepaid freight. Package pump in original packaging or similar to prevent damage in shipment. Warranty determinations will be made after the product has been received and inspected.

This warranty is in lieu of all other warranties, express or implied, and Ace Pump Corporation does not authorize any other person to assume for it any obligation or liability in connection with the sale of said pumps, valves, or any parts thereof.

WARNING: Pumps returned to Ace must be free of chemical hazard. Chemicals must be neutralized and thoroughly rinsed. Pumps with indications of active chemical will not be considered for repair or warranty.



Ace Pump Corporation • P.O. Box 13187 - 1650 Channel Avenue • Memphis, TN 38113
www.AcePumps.com • Phone: 901-948-8514 • Fax: 901-774-6147

Ace Form # PTOC-MAN
Revised 05/09