

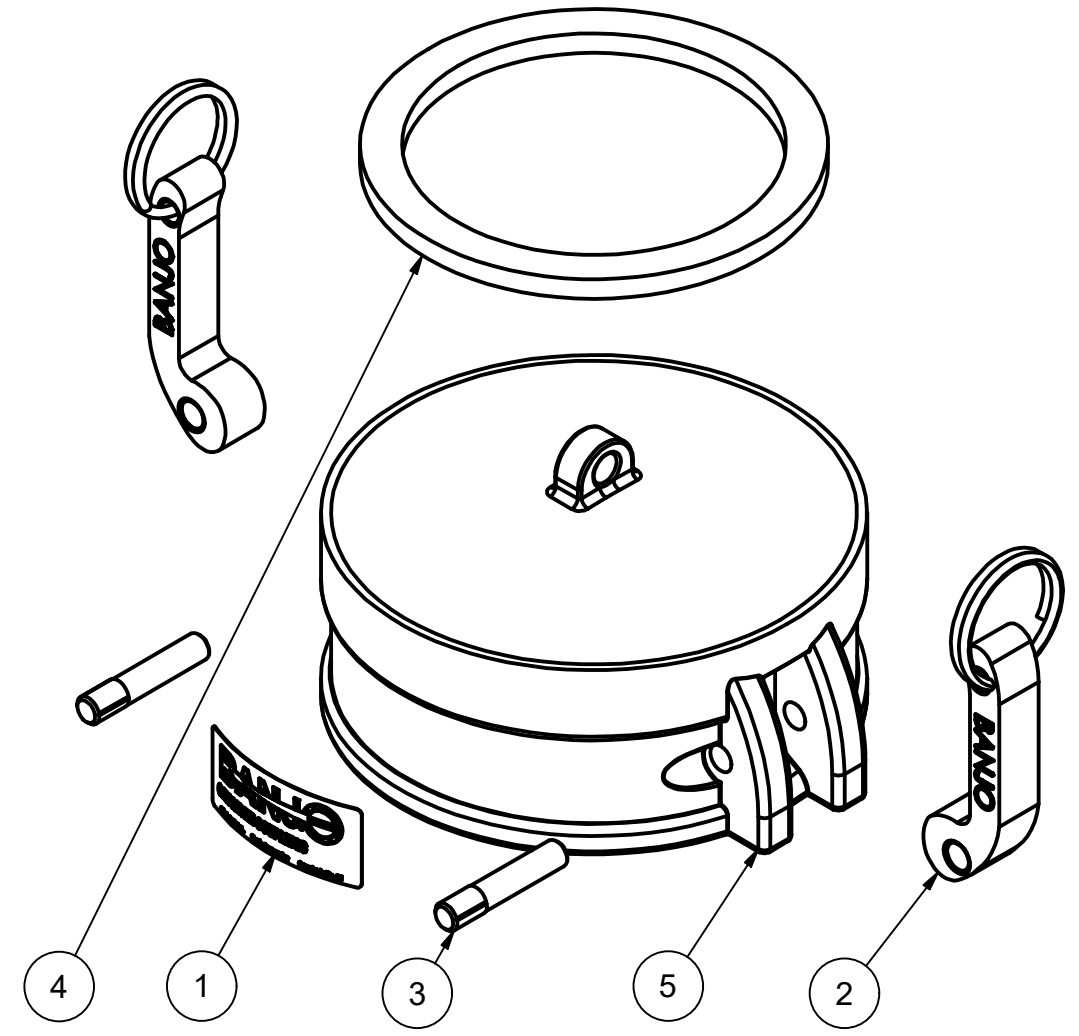

PARTS LIST			
ITEM	QTY	PART NUMBER	DESCRIPTION
1	1	150(200)D	CAM LEVER COUPLING DECAL
2	2	300K	CAM ARM
3	2	300P	CAM ARM PIN
4	1	400G	4" Coupling Gasket
5	1	400XCAP	4" CAP, MOLDED

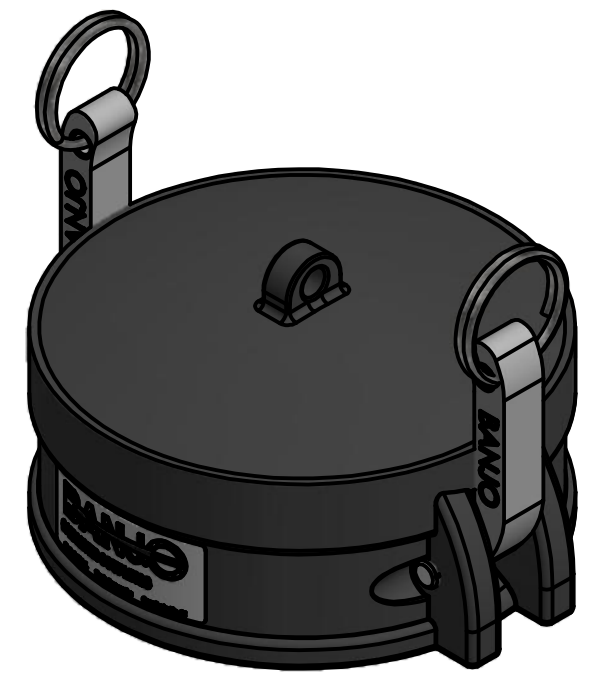

THIS DRAWING AND ALL INFORMATION CONTAINED THEREON ARE THE EXCLUSIVE PROPERTY OF BANJO CORPORATION.

UNLESS SPECIFICALLY NOTED, THIS DRAWING AND ITEMS SHOWN ON THIS DRAWING ARE SUBJECT TO CHANGE AT ANY TIME.



**BANJO CORPORATION**

150 BANJO DRIVE, CRAWFORDSVILLE, IN 47933  
 WEB SITE: WWW.BANJOCORP.COM  
 E-MAIL: BANJOSALES@IDEXCORP.COM

DESCRIPTION	4" CAP
PART NUMBER	400CAP

B

B

A

A

4

3

2

1

4

3

2

1