

PARTS LIST			
ITEM	QTY	PART NUMBER	DESCRIPTION
1	6	V20010SS	3/8-16 X 2" HHCS
2	6	V20018	3/8" LOCKWASHER
3	6	V20019	3/8" HEX NUT
4	1	V25020	3/8" Handle Bolt
5	1	V25121	3/8" Fender Washer
6	1	V25153	2" FP HANDLE
7	1	V25160	Stem Bushing
8	1	V25163	AS568A -214 O-RING, FKM, BROWN
9	1	V30151B	STEM 3" & 4" STUBBY, MACHINED
10	1	V35255C	3" FP BALL, TUMBLED
11	1	V35265	AS568A -160 O-RING, FKM, BROWN
12	2	VS35258	3" FP Stubby Valve Seat
13	1	VSB35356	3" FP STBY FML CPLR EP
14	1	VSHB35254	3" FP STUBBY HB BODY, MACHINED

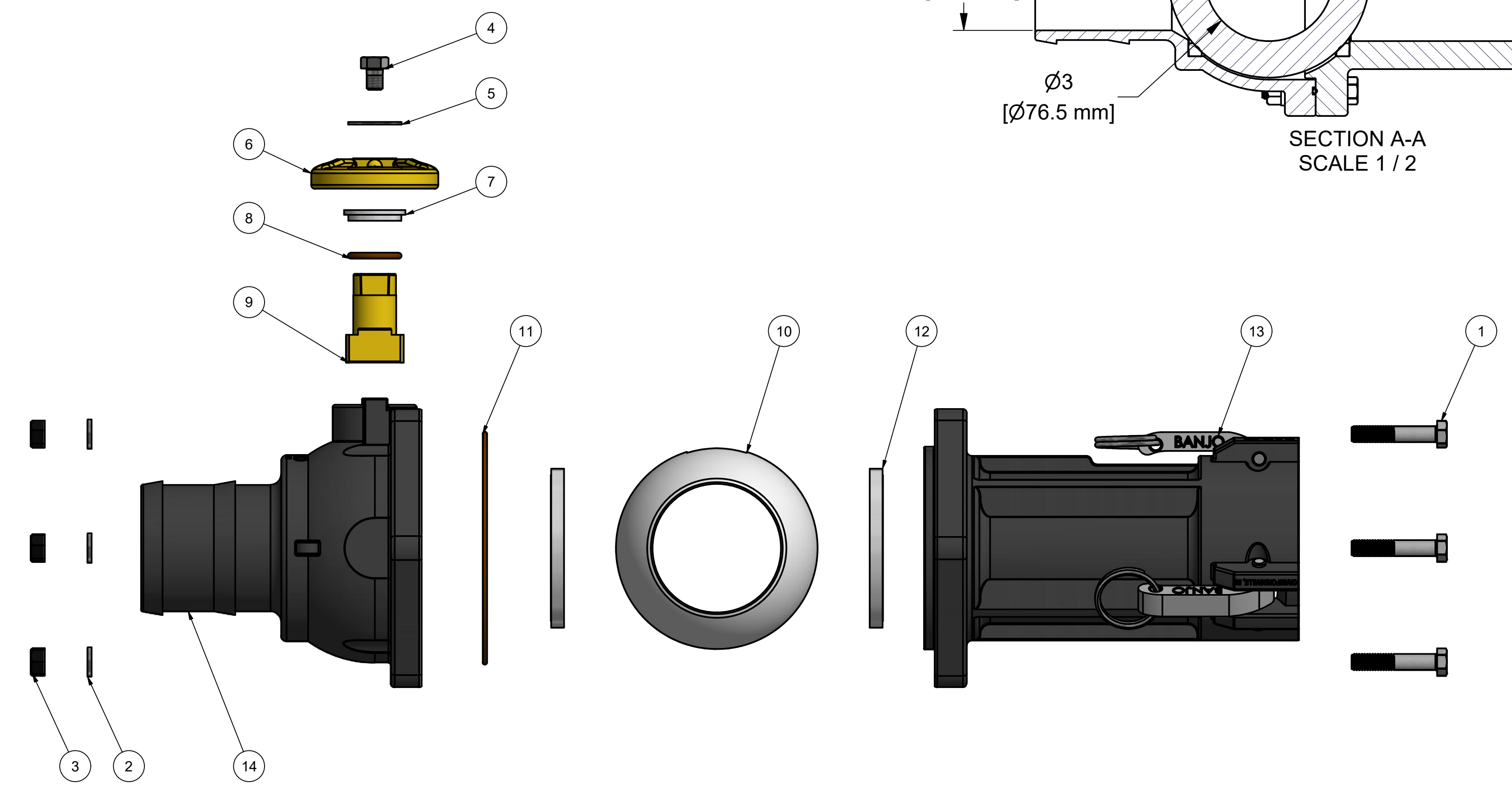
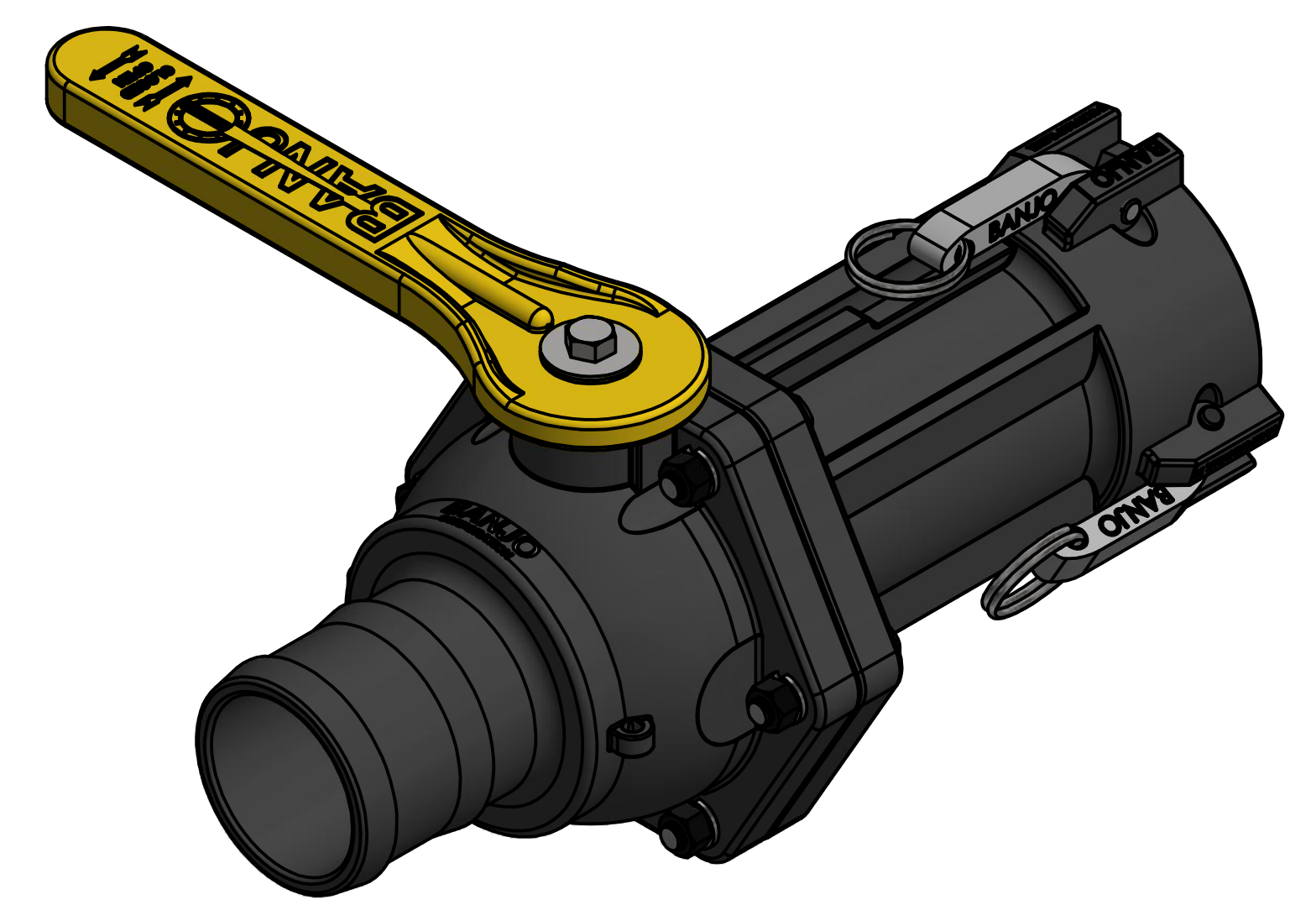

THIS DRAWING AND ALL INFORMATION CONTAINED THEREON ARE THE EXCLUSIVE PROPERTY OF BANJO CORPORATION.

UNLESS SPECIFICALLY NOTED, THIS DRAWING AND ITEMS SHOWN ON THIS DRAWING ARE SUBJECT TO CHANGE AT ANY TIME.

BANJO CORPORATION  
 150 BANJO DRIVE, CRAWFORDSVILLE, IN 47933  
 WEB SITE: WWW.BANJO.CORP.COM  
 E-MAIL: BANJOSALES@IDEXCORP.COM

DESCRIPTION  
**3" HOSE SHANK X 3" FEMALE COUPLER STUBBY VALVE**

PART NUMBER  
**VSHB304FP**