

CONTINENTAL NH3 PRODUCTS INSTALLATION, OPERATION, REPAIR AND MAINTENANCE INSTRUCTIONS

PRODUCT SERIES: A-2525-H, A-215, A-215-L, A-216-L, A-1625

ATTENTION: Please follow all of the instruction in this manual carefully and read the entire manual completely, failure to do so may cause the product to function improperly or fail causing serious injury or death.

DANGER  **DANGER**

ANHYDROUS AMMONIA IS AN INHALATION HAZARD AND WILL CAUSE SERIOUS INJURY OR DEATH. PLEASE USE EXTREME CAUTION WHEN HANDLING IT OR PERFORMING ANY MAINTENANCE ON EQUIPMENT USED FOR ANHYDROUS AMMONIA.

ATTENTION: Before performing any installation, repair or maintenance please follow the instructions below.

1. You must be certified to work with anhydrous ammonia. If you are not please seek out the appropriate agricultural department to attend a class to obtain the proper certification.
2. Wear appropriate safety goggles, gloves and breathing apparatuses.
3. Drain all tanks, hoses and piping of anhydrous ammonia COMPLETELY before removing, installing, performing maintenance or repairing any equipment.
4. Always remove device from service before performing any maintenance or repair
5. have sufficient water near by
6. Obey all local, state and federal laws regarding the handling of anhydrous ammonia

INSTALLATION & OPERATION

1. Apply pipe thread sealant to any male pipe thread to be installed into valve.
2. Make sure the valve is turned off before installation.
3. Make sure valve is facing the appropriate direction in relation to flow
4. install valve into pipe or hose assemble and tighten using appropriate wrench
5. Before operating valve make sure valve is attached to appropriate piping, hose or fitting.
6. Before operating the valve make sure there is appropriate hoses and valves are attached to the outlet side of the valve. Never open valve with out appropriate hoses and valve down stream of the valve, doing so will release anhydrous ammonia into the air that could cause sever injury.
7. Before open the valve turn off any down steam valve to prevent ammonia from spraying out into the air.
8. To open valve turn hand wheel counter clockwise all the way until the hand wheel stops turning. NEVER OPEN VALVE PARTIALLY; DOING SO WILL PREVENT ANY EXCESS FLOW CHECK IN THE SYSTEM FROM FUNCTIONING PROPERLY.
9. To close valve turn hand wheel counter clockwise and tighten firmly. NEVER LEAVE VALVE OPEN UNATTENDED OR WHILE TRAVELING DOWN A ROAD. VALVE SHOULD ONLY BE OPEN WHILE IN USE.
10. If valve is attached to a coupling, follow step 8 then drain connection with appropriate bleeder valve. Pay close attention to the direction the bleeder valve port is facing and make sure it's pointing in a safe direction. See Coupling and bleeder valve operational instruction for more detailed instruction,

MAINTENANCE

1. Check valve regularly for leaks and wear.
2. If any threads on the valve are getting warned down replace the valve immediately
3. If valve leaks from pipe thread connection try to tighten the valve to stop the leak. If it continues to leak replace the valve.
4. If valve leaks from bonnet 25H-10, seat 22-60, stem 25H-53 or packing nut 25H-14 either replace valve or install repair kit, A-25H-RK immediately.

REPAIR

1. Remove valve from service by following the above ATTENTIONS AND CAUTIONS.
2. Remove bonnet assembly 25H-10 from valve body and remove hand wheel from bonnet assembly
3. Remove stem 25H-5312 and packing nut 25H-14 and remove all of the packing from the bonnet 25H-10.
4. Unscrew 22-13 Allen screw from the stem 25H-5312 and replace the 22-74-F o-ring and 25H-60 seat and replace the Allen screw and tighten firmly.
5. reinstall the 25H-30 washer bevel side up and install spring 25H-900 and place the seat tension washer 25H-31.
6. Remove and replace the Teflon packing 25H-62-F , o-ring 25H-8111 and pack nut gasket 25H-81-FX from the packing nut 25H-14 and screw in the packing nut back, with grease on the threads into the bonnet 25H-10 and hand tighten only. Please note the packing nut gasket sometimes gets stuck in the bonnet please make sure to remove it before installing the packing nut.
7. Reinstall the 25H-5312 stem into the bonnet 25H-10 by pushing little and turning clockwise simultaneously until the stem is completely screwed all the way to the bonnet.
8. Put thread sealant on the threads of the bonnet that screws into the valve body and replace the 25H-80-FX bonnet gasket and reinstall the bonnet into the valve body and tighten the bonnet with a wrench.
9. Tighten packing nut firmly with appropriate wrench. And reinstall hand wheel.
10. Reinstall the valve into service by following the above installation instructions.

QUESTIONS CALL 800-537-5642

Catalog Number	Description	List Price	100 Piece Ship Wgt.
25H SERIES VALVES HIGH FLOW TANK & GLOBE VALVES CATALOG NUMBERS A-215, A-215-L, A-2525H, A-1406, A-1407			
22-07-FX	HANDWHEEL		
22-13	SEAT RETAINER SCREW		
22-85-F	HAND WHEEL LOCK WASHER		
22-86-F	HAND WHEEL LOCK NUT		
25H-01	BODY ONLY EXCLUDES PLUGS		
25H-10-X	BONNET		
25H-14-X	PACKING NUT		
25H-30-X	SPRING RETAINER WASHER (HARD ANIDIZED)		
25H-31-X	PACKING WASHER		
25H-5312	STEM & SWIVEL POPPET ASSEMBLY		
25H-60	SEAT		
25H-62-F	TEFLON "V" PACKING		
25H-786	COMPLETE BONNET AND HANDWHEEL ASSEMBLY		
25H-80-FX	BONNET GASKET		
25H-8111	UPPER STEM SEAL O-RING		
25H-81-FX	PACKING NUT GASKET		
25H-900	SPRING		
A-25H-RK	REPAIR KIT INCLUDES: 25H-60, 25H-62-F, 25H-80-FX, 25H-81-FX, 25H-8111, 25H-900		

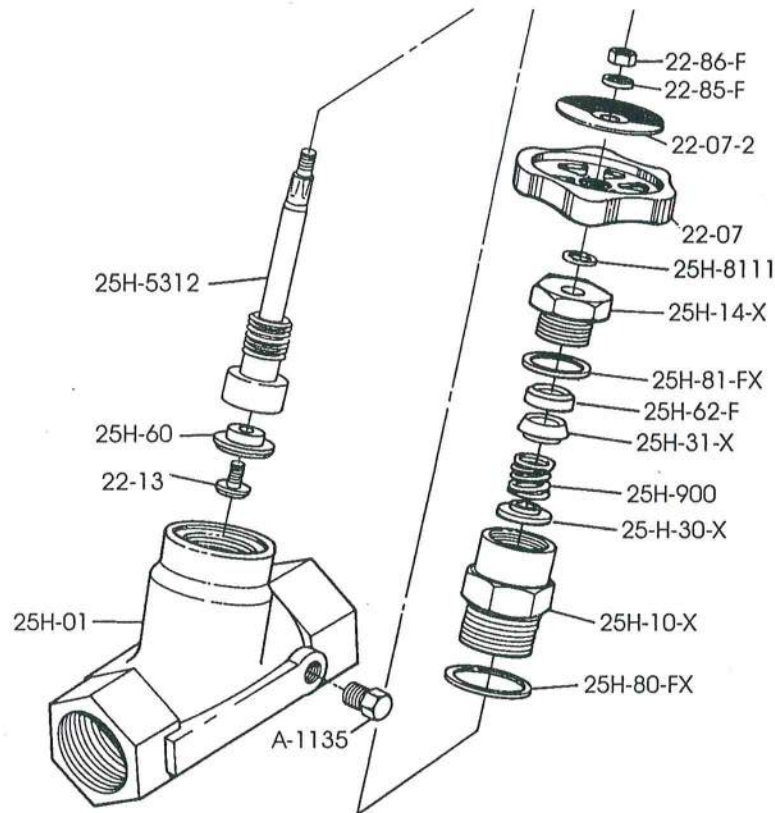

CONTINENTAL NH 3 PRODUCTS CO., INC.

130 YORKTOWN

P.O. BOX 225323

DALLAS, TEXAS 75222-5323

800-537-5642