

Dalton

A G P R O D U C T S



PARTS MANUAL

DISC SEALERS & SPRING LOADS



www.DaltonAg.com

602 E. VAN BUREN | LENOX, IOWA 50851 | 800.342.7498

DISC SEALERS

STANDARD INDEPENDENT STYLE

PART #: 4410171

Our Standard Independent Style arms work with variable pitch on blades, which works well in no-till fields. The blades will move dirt that has been displaced back into place. The arms pivot on the 1.25" shaft with non-greasable composite bushings. The adjustable blades allow for minimum to maximum soil disturbance.

Arms are also available in off-set design

18" NOTCHED BLADES

The large 18" notched blades have a small concave shape which allows you to run the blade straighter reducing wear and tear on bearings and spindles, minimizing disc track. The variable blade pitch adjustment and three-hole design gives you the ability to adjust to your field conditions.

SIDE-DRESS INDEPENDENT STYLE

PART #: 4410185

Our Side-Dress Independent Style disc sealers are designed with 14.5" arms. These 18" blades are located beside the knife to reduce throwing of dirt on young plants. This unit also pivots on a 1.25" shaft with non-greasable composite bushings.

HEAVY DUTY INDEPENDENT STYLE

PART #: 4410223

Our Heavy Duty Independent style disc sealer covers better, lasts longer and is more trouble free than any other on the market today. The independent arm design and the large 18" notched blade provides better knife track coverage and keeps the trash flowing through without build-up or plugging, it also provides better coverage in uneven terrain and allows you to be more productive.

The heavy duty design is based on tapered roller bearings instead of plastic, fiber or bronze bushings. Heavier overall components and eliminations of springs increases the lifetime of our disc sealers.

Contact your local Dalton Ag dealer today for all of your Dalton Ag part needs!

Phone: 800.342.7498

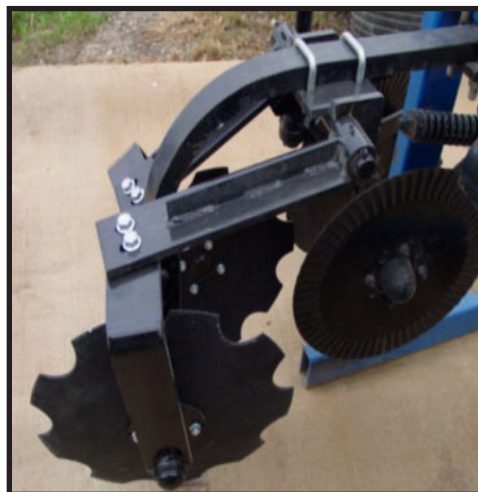

SIMPLE. DURABLE. AMERICAN.

www.DaltonAg.com

TABLE OF CONTENTS

Independent Style.....	1
Independent Style with Offset Arms.....	2
Heavy Duty Disc Sealer.....	3
Heavy Duty Disc Sealer with Offset Arms.....	4
Independent Style with 14.5” Arms.....	5
Independent Style, Center Searler with 14” Notched Blades.....	6
High Clearance Shank Disc Sealer.....	7
High Clearance Shank Disc Sealer with Offset Arms.....	8
Spring Loaded Shank Clamp.....	9
Spring Loaded Shank Clamp, 6 X6.....	10
Parts Ordering Procedure.....	11

4410171 INDEPENDENT STYLE

4410171 INDEPENDENT STYLE

#	PART NUMBER	QTY.
1	4410171 INDEPENDENT STYLE Δ	1
2	4410174 UPPER MOUNTING BRACKET □	1
3	DS 4420271 SHANK MOUNTING BRACKET	1
4	DS 4410256 PIVOT ARM W BUSHING, LH	1
5	4440857 BUSHING, COMPOSITE	2
6	DS 4410255 PIVOT ARM W BUSHING, RH	1
7	150251 FLAT WASHER, 1.25 ID x 1.875 OD	2
8	101689 SPRING PIN .375x2	2
9	4420277 HUB ASSEMBLY, STD □	2
10	DS 4420273 HUB BRACKET, STD, WELDMENT	1
11	DS 4420201 SPINDLE HUB, STD, WELDMENT	1
12	151222 GREASE ZERK, .25 SELF TAPPING	1
13	4440704 SEAL	1
14	4440702 BEARING	2
15	4440703 RACE	2
16	150224 FLAT WASHER, .625	1
17	4440737 SLOTTED NUT,	1
18	150406 COITTER PIN, .125 x 2	1
19	QDS909923 DUST CAP, 1.75	1
20	151835 CARRIAGE BOLT, .375x.75 NC PLTD	8
21	DS 4440785 BLADE, 18 INCH NOTCHED	2
22	158005 FLANGE NUT, .375 NC	8
23	158006 FLANGE BOLT, .5 NC x 1.75. G5	4
24	158007 FLANGE NUT, .5 NC	8
25	4440788 U-BOLT, 2 x 2.5 x .5 NC, SQUARE HEAD	2

ALL QUANTITIES ARE PER ROW UNIT

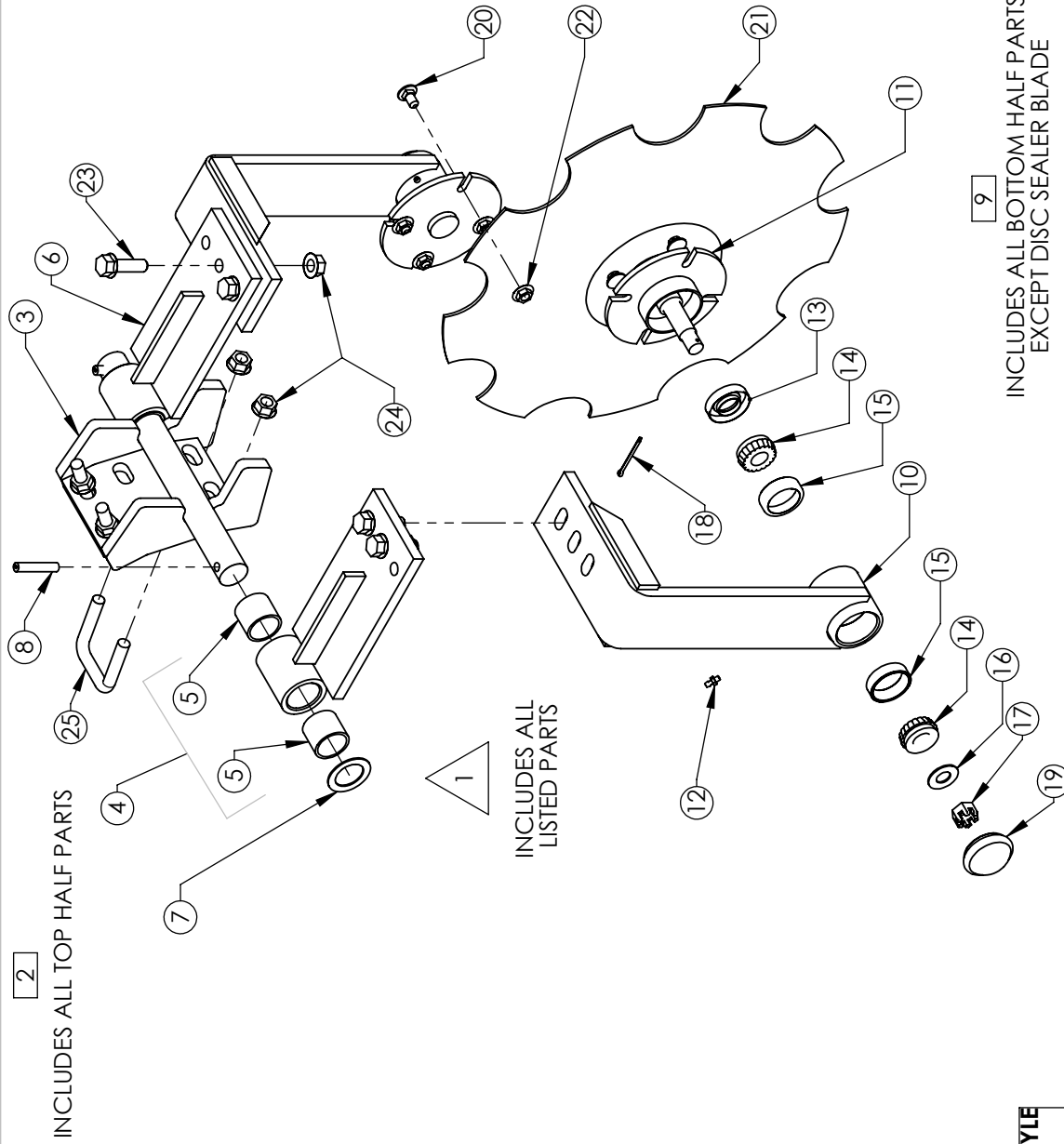

**4410171 INDEPENDENT STYLE
INCLUDES ALL ITEMS**

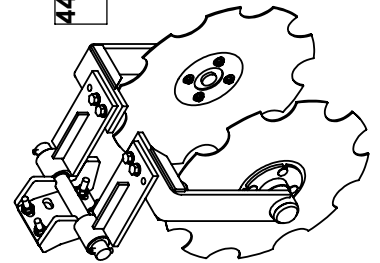

DRAWN BY	RICH SMOTHERS	10/21/2013
CHECKED BY		
PRINT DATE	11/14/2014	
CONFIG.	EXP VIEW	
COMMENTS:	4410171 INDEPENDENT STYLE	
<p>PROPRIETARY AND CONFIDENTIAL THE INFORMATION CONTAINED IN THIS DRAWING IS THE SOLE PROPERTY OF DALTON AG. ANY REPRODUCTION IN PART OR AS A WHOLE WITHOUT THE WRITTEN PERMISSION OF DALTON AG IS PROHIBITED.</p>		
DWG:	4410171 INDEPENDENT STYLE	
SIZE	A	B.O.M.
SHEET TITLE:		REV
SCALE:	1:7	A
		SHEET 1 OF 1

INCLUDES ALL BOTTOM HALF PARTS EXCEPT DISC SEALER BLADE



FOR PARTS, CALL 1.800.342.7498

4410171 OS INDEPENDENT STYLE WITH OFFSET ARMS

4410171 OS INDEPENDENT STYLE WITH OFFSET ARMS

#	PART NUMBER	Q.
1	4410171 OS INDEPENDENT STYLE WITH OFFSET ARMS Δ	1
2	DS 4410174 OS UPPER MOUNTING BRACKET, OFFSET □	1
3	DS 4420271 SHANK MOUNTING BRACKET	1
4	DS 4410256 PIVOT ARM W BUSHING, LH	1
5	4440857 BUSHING, COMPOSITE	2
6	150251 FLAT WASHER, 1.25 ID x 1.875 OD	2
7	101689 SPRING PIN .375x2	2
8	DS 4410303 PIVOT ARM, LONG, RH	1
9	4420277 HUB ASSEMBLY, STD □	2
10	DS 4420273 HUB BRACKET, STD, WELDMENT	1
11	DS 4420201 SPINDLE HUB, STD, WELDMENT	1
12	151222 GREASE ZERK, .25 SELF TAPPING	1
13	4440704 SEAL	1
14	4440702 BEARING	2
15	4440703 RACE	2
16	150224 FLAT WASHER, .625	1
17	4440737 SLOTTED NUT,	1
18	150406 COITER PIN, .125 x 2	1
19	QDS909923 DUST CAP, 1.75	1
20	151835 CARRIAGE BOLT .375x.75 NC PLTD	8
21	DS 4440785 BLADE, 18 INCH NOTCHED	2
16	158005 FLANGE NUT, .375 NC	8
23	158006 FLANGE BOLT, .5 NC x 1.75, G-5	4
24	158007 FLANGE NUT, .5 NC	8
25	4440788 U-BOLT, 2 x 2.5 x .5 NC, SQUARE HEAD	2

ALL QUANTITIES ARE PER ROW UNIT

**** TO REVERSE OFFSET ****

**USE 4410304 PIVOT ARM, LONG, LH AND
4410255 PIVOT ARM W BUSHING, RH**

**4410171 OS INDEPENDENT STYLE
WITH OFFSET ARMS
INCLUDES ALL ITEMS**

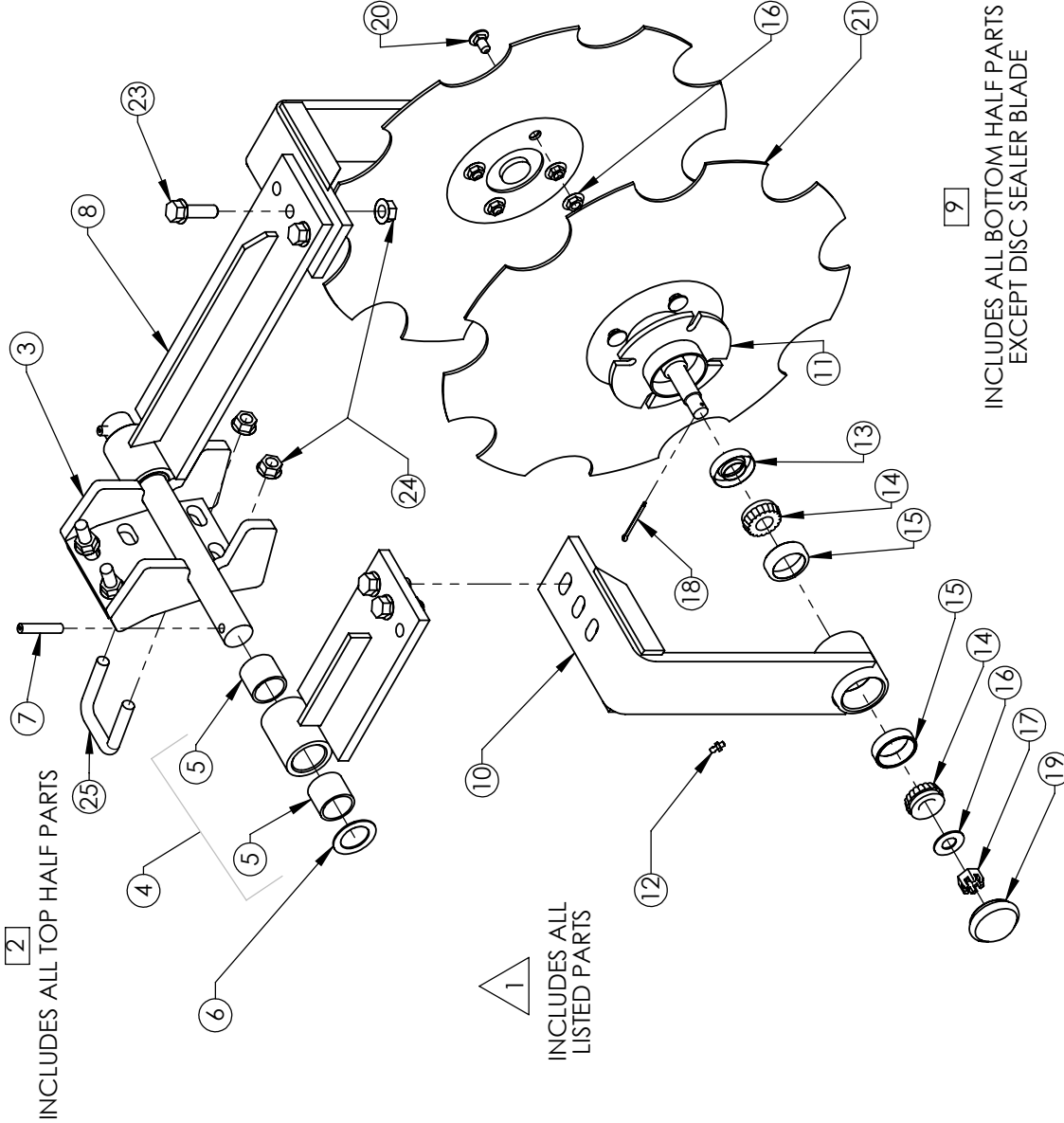
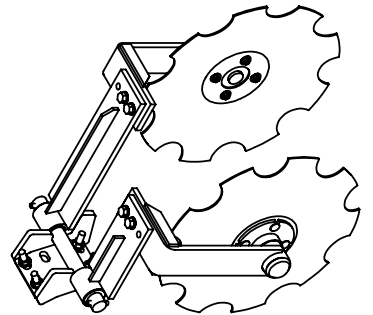

INCLUDES ALL TOP HALF PARTS

INCLUDES ALL LISTED PARTS

INCLUDES ALL BOTTOM HALF PARTS EXCEPT DISC SEALER BLADE

DRAWN BY RICH SMOTHERS 10/21/2013

CHECKED BY

PRINT DATE 11/14/2014

CONFIG. EXP VIEW

COMMENTS:

**4410171 OS INDEPENDENT STYLE
WITH OFFSET ARMS**

PROPRIETARY AND CONFIDENTIAL
THE INFORMATION CONTAINED IN THIS DRAWING IS THE SOLE PROPERTY OF DALTON AG. ANY REPRODUCTION IN PART OR AS A WHOLE WITHOUT THE WRITTEN PERMISSION OF DALTON AG IS PROHIBITED.



DWG: 4410171 OS INDEPENDENT STYLE WITH OFFSET ARMS

SIZE SHEET TITLE: **A** B.O.M.
REV **A**

FOR PARTS, CALL 1.800.342.7498

SCALE: 1:7

SHEET 1 OF 1

4410223 HEAVY DUTY DISC SEALER

4410223 HD DISC SEALER

#	PART NUMBER	Q
1	4410223 HD DISC SEALER Δ	1
2	4420310 HD UPPER MOUNTING ASSEMBLY □	1
3	DS 4420302 UPPER MOUNTING BRACKET, HD, WELDMENT	1
4	DS 4420303 PIVOT ARM, HD	2
5	4440815 SEAL	2
6	4440816 BEARING	4
7	4440817 RACE	4
8	158003 SLOTTED NUT, .75 NC	2
9	158012 SPINDLE WASHER, .75	2
10	150409 COTTER PIN, .125 x 1.5, PLAIN	2
11	4440814 DUST CAP, 2 INCH	2
12	158007 FLANGE NUT, .5 NC	4
13	151222 GREASE ZERK, .25 SELF TAPPING	2
14	4440788 U-BOLT, 2 x 2.5 x .5 NC, SQUARE HEAD	2
15	158006 FLANGE BOLT, .5 NC x 1.75, G5	4
16	158007 FLANGE NUT, .5 NC	4
17	4420309 HD HUB ASSEMBLY □	1
18	DS 4420304 HUB BRACKET, WELDMENT, HD	1
19	DS 4420305 SPINDLE HUB, HD, WELDMENT	1
20	150409 COTTER PIN, .125 x 1.5, PLAIN	1
21	4440814 DUST CAP, 2 INCH	1
22	151222 GREASE ZERK, .25 SELF TAPPING	1
23	4440817 RACE	2
24	4440816 BEARING	2
25	4440815 SEAL	1
26	158012 SPINDLE WASHER, .75	1
27	158002 SLOTTED NUT, .75 NC THIN	1
28	DS 4440785 BLADE, 18 INCH NOTCHED	1
29	158004 FLANGE BOLT, .375 NC x .75, G5	4
30	158005 FLANGE NUT, .375 NC	4

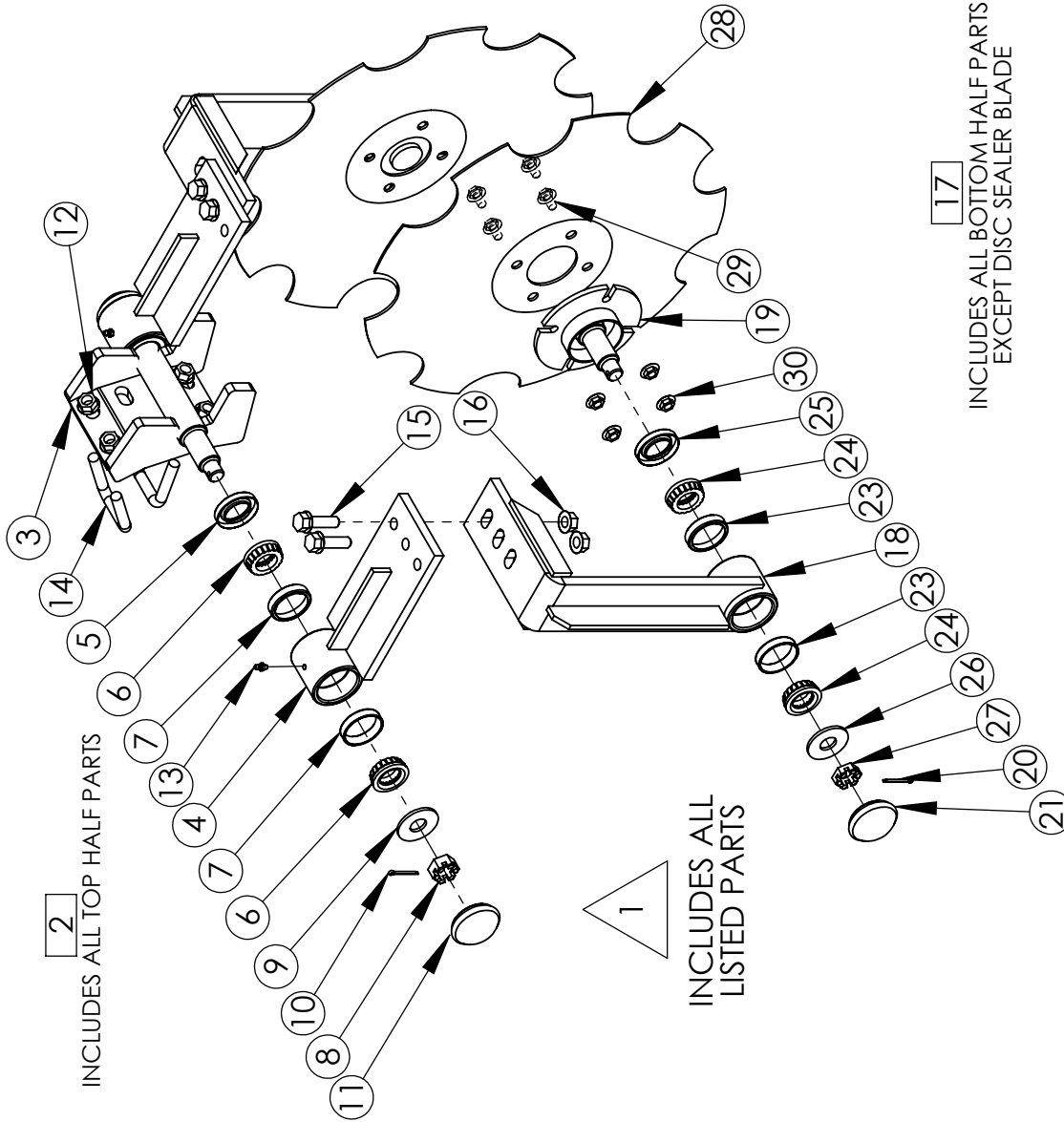

INCLUDES ALL TOP HALF PARTS

INCLUDES ALL LISTED PARTS

INCLUDES ALL BOTTOM HALF PARTS EXCEPT DISC SEALER BLADE

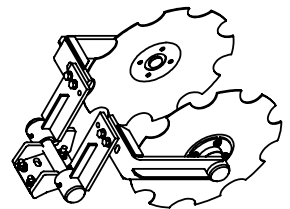

4410223 HD DISC SEALER

DRAWN BY	RICH SMOTHERS	4/28/2009
CHECKED BY		
PRINT DATE	11/14/2014	
CONFIG.	EXPLODED	
COMMENTS:		
<p>PROPRIETARY AND CONFIDENTIAL THE INFORMATION CONTAINED IN THIS DRAWING IS THE SOLE PROPERTY OF DALTON AG. ANY REPRODUCTION IN PART OR AS A WHOLE WITHOUT THE WRITTEN PERMISSION OF DALTON AG IS PROHIBITED.</p>		
DWG:	4410223 HD DISC SEALER	
SIZE	A	ASSEMBLY
SHEET TITLE:	4410223 HD DISC SEALER	
SCALE:	1:8	SHEET 1 OF 1



4410223 OS HEAVY DUTY DISC SEALER WITH OFFSET ARMS

4410223 OS HD DISC SEALER WITH OFFSET ARMS

#	PART NUMBER	Q
1	4410223 OS HD DISC SEALER WITH OFFSET ARMS Δ	1
2	4420310 OS HD UPPER MOUNTING ASSEMBLY □	1
3	DS 4420302 UPPER MOUNTING BRACKET, HD, WELDMENT	1
4	DS 4420303 PIVOT ARM, HD	1
5	4440815 SEAL	2
6	4440816 BEARING	4
7	4440817 RACE	4
8	158003 SLOTTED NUT, .75 NC	2
9	158012 SPINDLE WASHER, .75	2
10	150409 COTTER PIN, .125 x 1.5, PLAIN	2
11	4440814 DUST CAP, 2 INCH	2
12	158007 FLANGE NUT, .5 NC	4
13	151222 GREASE ZERK, .25 SELF TAPPING	2
14	4440788 U-BOLT, 2 x 2.5 x .5 NC, SQUARE HEAD	2
15	4420581 PIVOT ARM, HD, LONG	1
16	158006 FLANGE BOLT, .5 NC x 1.75, G5	4
17	158007 FLANGE NUT, .5 NC	4
18	4420309 HD HUB ASSEMBLY □	2
19	DS 4420304 HUB BRACKET, WELDMENT, HD	1
20	DS 4420305 SPINDLE HUB, HD, WELDMENT	1
21	150409 COTTER PIN, .125 x 1.5, PLAIN	1
22	4440814 DUST CAP, 2 INCH	1
23	151222 GREASE ZERK, .25 SELF TAPPING	1
24	4440817 RACE	2
25	4440816 BEARING	2
26	4440815 SEAL	1
27	158012 SPINDLE WASHER, .75	1
28	158002 SLOTTED NUT, .75 NC THIN	1
29	DS 4440785 BLADE, 18 INCH NOTCHED	1
30	158004 FLANGE BOLT, .375 NC x .75, G5	4
31	158005 FLANGE NUT, .375 NC	4

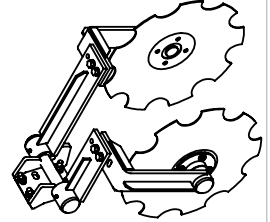
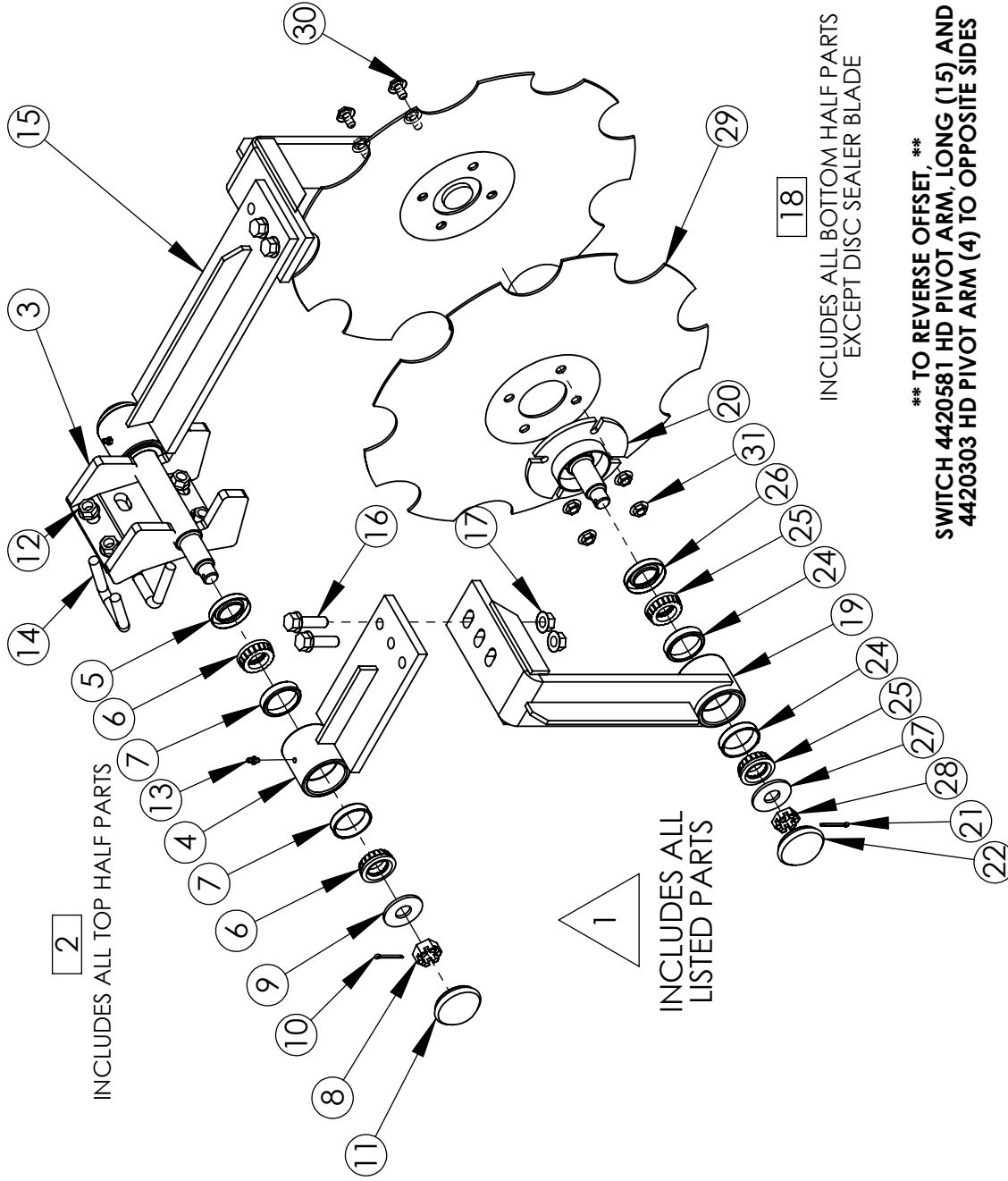

4410223 OS HD DISC SEALER WITH OFFSET ARMS

PROPRIETARY AND CONFIDENTIAL
 THE INFORMATION CONTAINED IN THIS DRAWING IS THE SOLE PROPERTY OF DALTON AG. ANY REPRODUCTION IN PART OR AS A WHOLE WITHOUT THE WRITTEN PERMISSION OF DALTON AG IS PROHIBITED.

DRAWN BY RICH SMOTHERS 4/28/2009
 CHECKED BY
 PRINT DATE 11/14/2014
 CONFIG. EXPLODED
 COMMENTS:

DWG: 4410223 OS HD DISC SEALER WITH OFFSET ARMS
 USA
Dalton
 602 E. VAN BUREN ST., LENOX, IA 50851

SIZE SHEET TITLE: ASSEMBLY REV
A
 SCALE: 1:8 SHEET 1 OF 1

FOR PARTS, CALL 1.800.342.7498

4410185 INDEPENDENT STYLE WITH 14.5 INCH ARMS

4410185 INDEPENDENT STYLE W 14.5 INCH ARM

#	PART NUMBER	Q
1	4410185 INDEPENDENT STYLE W 14.5 INCH ARM	1
2	4410195 UPPER MOUNTING BRACKET ASSEMBLY	1
3	DS 4420287 UPPER MOUNTING BRACKET, LONG ARM FLOPPY, WELDMENT	1
4	DS 4410259 PIVOT ARM, LONG	2
5	DS 4435834 BUSHING, FLOPPY, LONG	1
6	DS 4435835 LONG FLOPPY, ARM MOUNTING PLATE	1
7	DS 4435836 LONG FLOPPY, ARM GUSSET	1
8	4440857 BUSHING, COMPOSITE	2
9	151222 GREASE ZERK, .25 SELF TAPPING	1
10	150251 FLAT WASHER, 1.25 ID x 1.875 OD	2
11	101689 SPRING PIN .375x2	2
12	158006 FLANGE BOLT, .5 NC x 1.75, G5	4
13	158007 FLANGE NUT, .5 NC	8
14	4440788 U-BOLT, 2 x 2.5 x .5 NC, SQUARE HEAD	2
15	4420277 HUB ASSEMBLY, STD	2
16	DS 4420273 HUB BRACKET, STD, WELDMENT	1
17	DS 4420201 SPINDLE HUB, STD, WELDMENT	1
18	151222 GREASE ZERK, .25 SELF TAPPING	1
19	4440704 SEAL	1
20	4440702 BEARING	2
21	4440703 RACE	2
22	150224 FLAT WASHER, .625	1
23	4440737 SLOTTED NUT,	1
24	150406 COTTER PIN, .125 x 2	1
25	QDS909923 DUST CAP, 1.75	1
26	151835 CARRIAGE BOLT .375x.75 NC PLTD	8
27	DS 4440785 BLADE, 18 INCH NOTCHED	2
13	158005 FLANGE NUT, .375 NC	8

ALL QUANTITIES ARE PER ROW UNIT
4410185 INDEPENDENT STYLE W 14.5 INCH ARM
INCLUDES ALL ITEMS

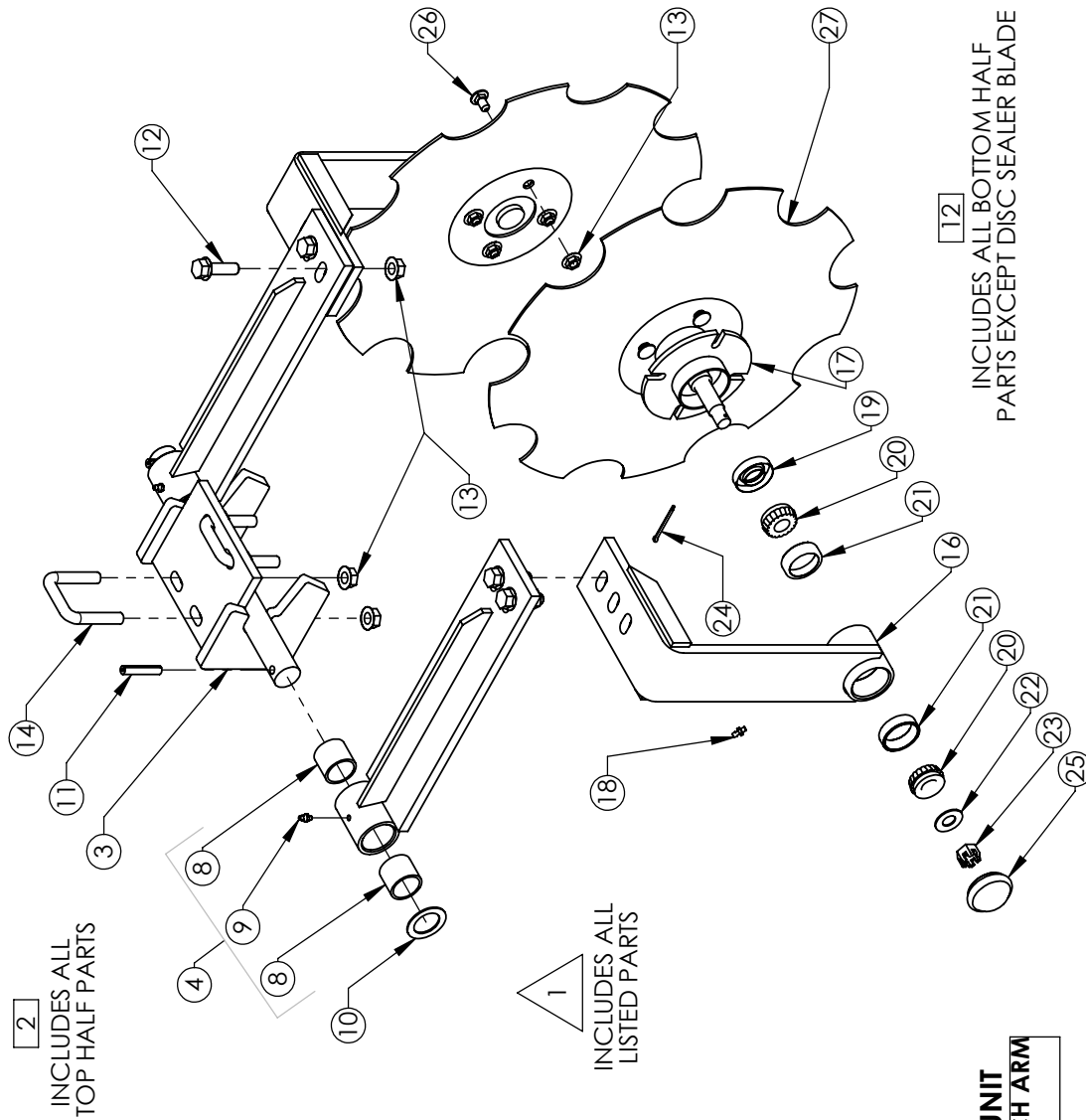

2 INCLUDES ALL TOP HALF PARTS

1 INCLUDES ALL LISTED PARTS

12 INCLUDES ALL BOTTOM HALF PARTS EXCEPT DISC SEALER BLADE

DRAWN BY RICH SMOTHERS 10/21/2013
 CHECKED BY
 PRINT DATE 11/14/2014
 CONFIG. EXP VIEW
 COMMENTS:



DWG: 4410185 INDEPENDENT STYLE W 14.5 INCH ARM

4410185 INDEPENDENT STYLE W 14.5 INCH ARM TITLE: B.O.M. REV A

PROPRIETARY AND CONFIDENTIAL
 THE INFORMATION CONTAINED IN THIS DRAWING IS THE SOLE PROPERTY OF DALTON AG. ANY REPRODUCTION IN PART OR AS A WHOLE WITHOUT THE WRITTEN PERMISSION OF DALTON AG IS PROHIBITED.

FOR PARTS, CALL 1.800.342.7498

SHEET 1 OF 1

4410190 INDEPENDENT STYLE, CENTER SEALER WITH 14" NOTCHED BLADES

4410190 INDEPENDENT STYLE, CENTER SEALER W 14 INCH NOTCHED BLADES

#	PART NUMBER	QTY.
1	4410190 INDEPENDENT STYLE, CENTER SEALER W 14 INCH NOTCHED BLADES Δ	1
2	DS 4410194 UPPER MOUNTING BRACKET, 14 INCH BLADE □	1
3	4420283 SHANK MOUNTING BRACKET	1
4	4410258 PIVOT ARM, SHORT, RH	1
5	4410257 PIVOT ARM, SHORT, LH	1
6	4440857 BUSHING, COMPOSITE	2
7	151222 GREASE ZERK, .25 SELF TAPPING	1
8	101689 SPRING PIN .375x2	2
9	150251 FLAT WASHER, 1.25 ID x 1.875 OD	2
10	158006 FLANGE BOLT, .5 NC x 1.75, G5	4
11	158007 FLANGE NUT, .5 NC	8
12	4440788 U-BOLT, 2 x 2.5 x .5 NC, SQUARE HEAD	2
13	158005 FLANGE NUT, .375 NC	8
15	DS 4440808 BLADE, 14 INCH NOTCHED	2
15	151835 CARRIAGE BOLT .375x.75 NC PLTD	8
16	4420284 DISC SEALER HUB ASSEMBLY □	2
17	DS 4420541 DISC SEALER, HUB BRACKET WLD ONLY, 14 INCH	1
18	4440703 RACE	2
19	4440702 BEARING	2
20	4440704 SEAL	1
21	150224 FLAT WASHER, .625	1
22	4440737 SLOTTED NUT,	1
23	150406 COTTER PIN, .125 x 2	1
24	DS 4420201 SPINDLE HUB, STD, WELDMENT	1
25	QDS909923 DUST CAP, 1.75	1
26	151222 GREASE ZERK, .25 SELF TAPPING	1

**4410190 INDEPENDENT STYLE,
CENTER SEALER W 14 INCH
NOTCHED BLADES
INCLUDES ALL ITEMS**

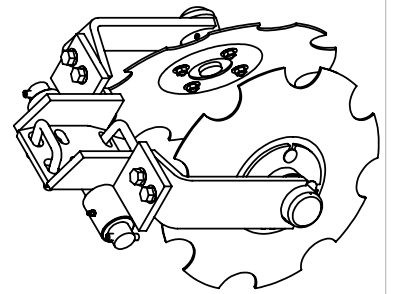

ALL QUANTITIES ARE PER ROW UNIT

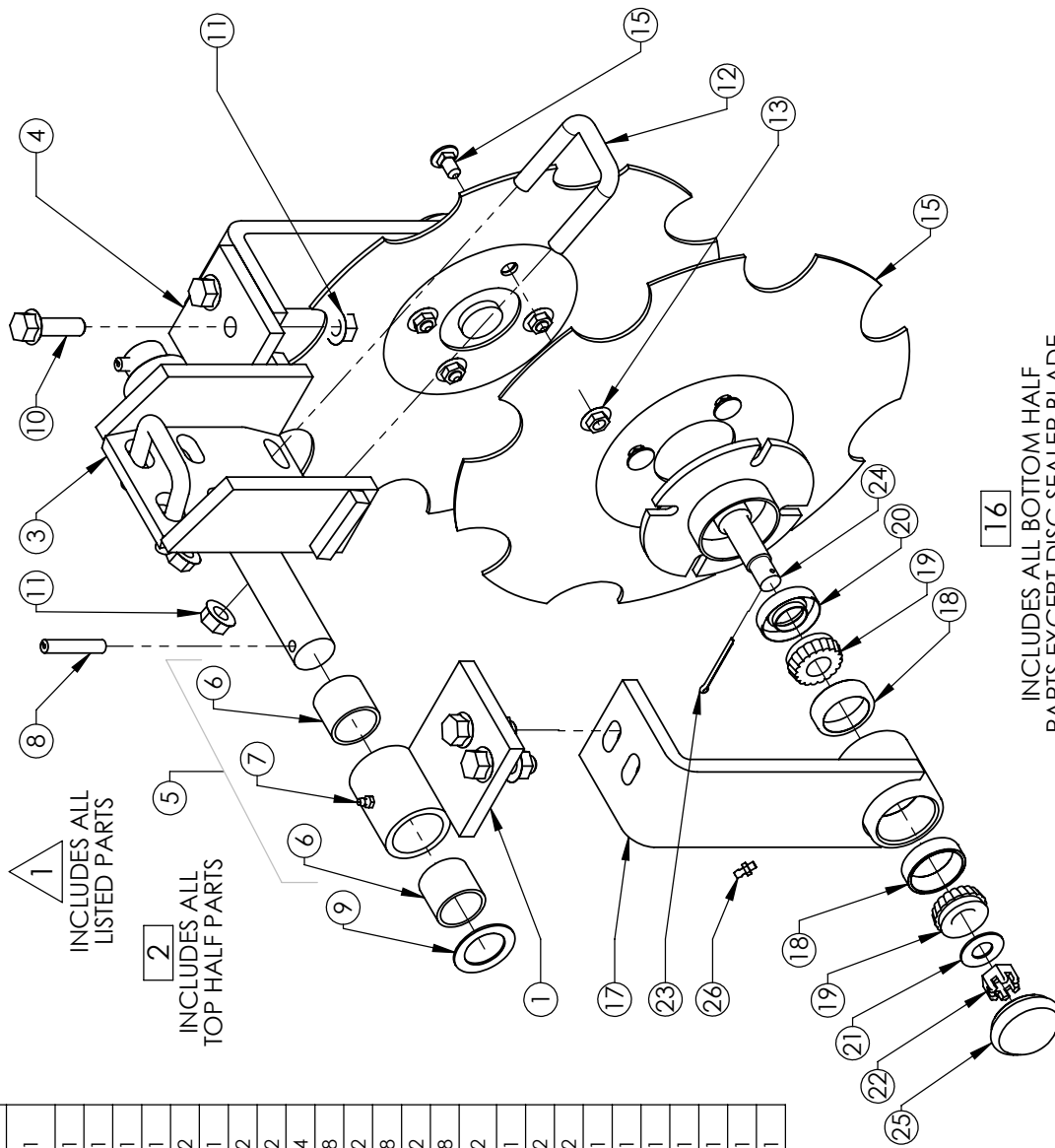

INCLUDES ALL BOTTOM HALF
PARTS EXCEPT DISC SEALER BLADE

DRAWN BY	RICH SMOTHERS	10/23/2013
CHECKED BY		
PRINT DATE	11/14/2014	
CONFIG.	EXP VIEW	
COMMENTS:	<p>4410190 INDEPENDENT STYLE, CENTER SEALER W 14 INCH NOTCHED BLADES</p>	
<p>PROPRIETARY AND CONFIDENTIAL THE INFORMATION CONTAINED IN THIS DRAWING IS THE SOLE PROPERTY OF DALTON A.G. ANY REPRODUCTION IN PART OR AS A WHOLE WITHOUT THE WRITTEN PERMISSION OF DALTON A.G IS PROHIBITED.</p>		
<p>DWG: 4410190 INDEPENDENT STYLE, CENTER SEALER W 14 INCH NOTCHED BLADES</p>		
SIZE	SHEET TITLE:	REV
A	B.O.M.	A
SCALE: 1:5		SHEET 1 OF 1

4410262 HIGH CLEARANCE SHANK DISC SEALER

4410262 HCS DISC SEALER

#	PART NUMBER	Q
1	4410262 HCS DISC SEALER ASSEMBLY	1
2	4410263 HCS UPPER MOUNT ASSEMBLY □	1
3	DS 4420497 HCS UPPER MOUNTING BRACKET	1
4	DS 4420303 PIVOT ARM, HD	2
5	4440815 SEAL	2
6	4440816 BEARING	4
7	4440817 RACE	4
8	158003 SLOTTED NUT, .75 NC	2
9	158012 SPINDLE WASHER, .75	2
10	150409 COTTER PIN, .125 x 1.5, PLAIN	2
11	4440814 DUST CAP, 2 INCH	2
12	151222 GREASE ZERK, .25 SELF TAPPING	2
13	4420309 HD HUB ASSEMBLY □	1
14	DS 4420304 HUB BRACKET, WELDMENT, HD	1
15	DS 4420305 SPINDLE HUB, HD, WELDMENT	1
16	150409 COTTER PIN, .125 x 1.5, PLAIN	1
17	4440814 DUST CAP, 2 INCH	1
18	151222 GREASE ZERK, .25 SELF TAPPING	1
19	4440817 RACE	2
20	4440816 BEARING	2
21	4440815 SEAL	1
22	158012 SPINDLE WASHER, .75	1
23	158002 SLOTTED NUT, .75 NC THIN	1
24	DS 4440785 BLADE, 18 INCH NOTCHED	1
25	158004 FLANGE BOLT, .375 NC x .75, G5	4
26	158005 FLANGE NUT, .375 NC	4
27	158006 FLANGE BOLT, .5 NC x 1.75, G5	4
28	158007 FLANGE NUT, .5 NC	4
29	152225 BOLT, .5 NC x 3, G8	2
30	150217 LOCK WASHER, .5	2
31	150060 LOCKNUT, .5 NC, PLTD	2

4410262 HCS DISC SEALER

INCLUDES ALL TOP HALF PARTS
EXCEPT DISC SEALER BLADE

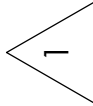
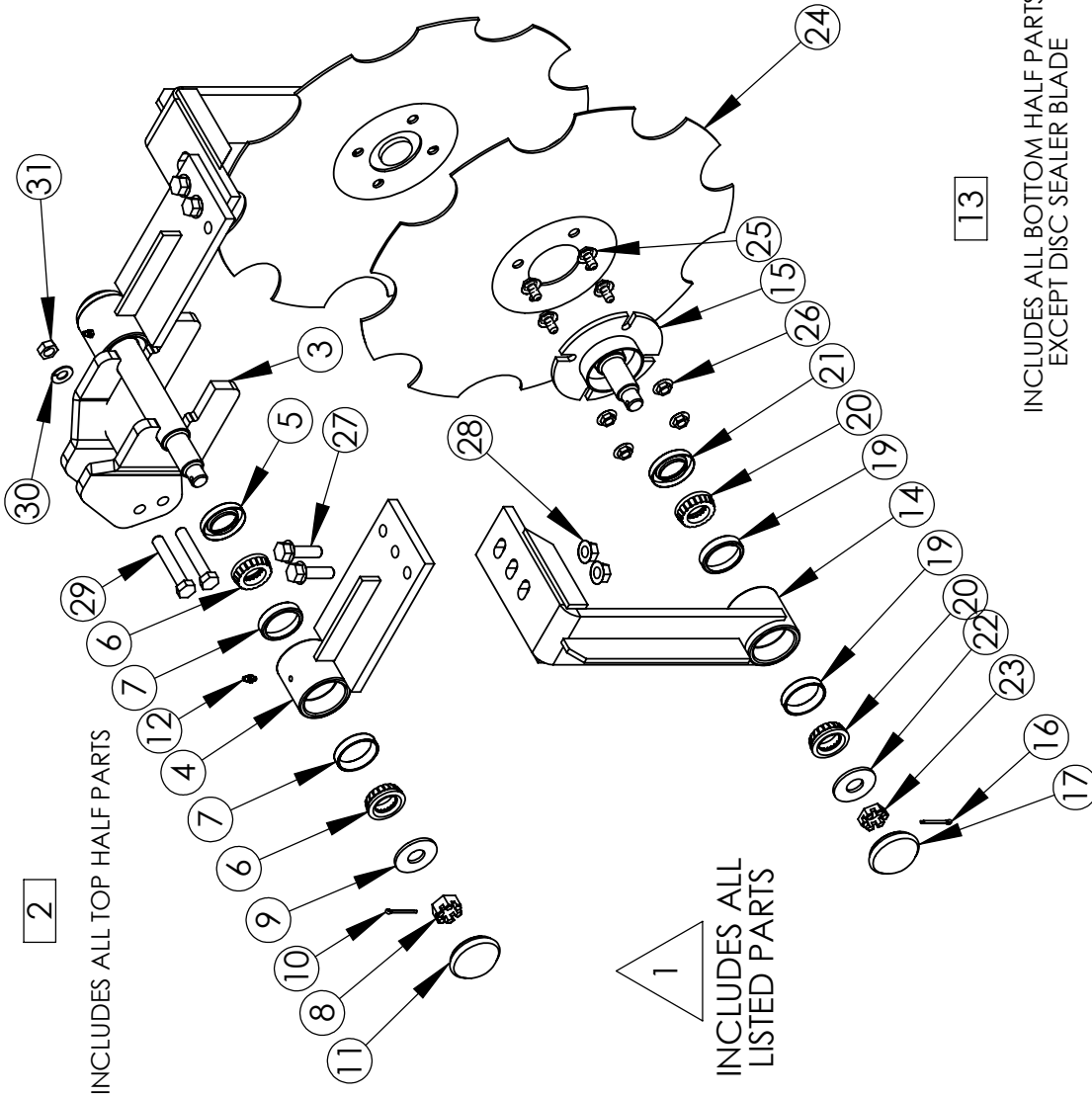

INCLUDES ALL LISTED PARTS

13

INCLUDES ALL BOTTOM HALF PARTS
EXCEPT DISC SEALER BLADE

DRAWN BY	RICH SMOTHERS	4/28/2009
CHECKED BY		
PRINT DATE	10/9/2014	
CONFIG.	EXPLODED	
COMMENTS:		



DWG: 4410262 HCS DISC SEALER

SIZE	A	REV	A
SHEET TITLE:	ASSEMBLY		
SCALE:	1:8	SHEET 1 OF 1	1

PROPRIETARY AND CONFIDENTIAL
THE INFORMATION CONTAINED IN THIS DRAWING IS THE SOLE PROPERTY OF DALTON A.G. ANY REPRODUCTION IN PART OR AS A WHOLE WITHOUT THE WRITTEN PERMISSION OF DALTON A.G IS PROHIBITED.

FOR PARTS, CALL 1.800.342.7498

4410262 OS HIGH CLEARANCE SHANK DISC SEALER, WITH OFFSET ARMS

4410262 OS HCS DISC SEALER, WITH OFFSET ARMS

#	PART NUMBER	Q
1	4410262 OS HCS DISC SEALER, WITH OFFSET ARMS	1
2	4410263 OS HCS UPPER MOUNT ASSEMBLY, w OFFSETTING ARMS	1
3	DS 4420497 HCS UPPER MOUNTING BRACKET	1
4	DS 4420303 PIVOT ARM, HD	1
5	4440815 SEAL	2
6	4440816 BEARING	4
7	4440817 RACE	4
8	158003 SLOTTED NUT, .75 NC	2
9	158012 SPINDLE WASHER, .75	2
10	150409 COTTER PIN, .125 x 1.5, PLAIN	2
11	4440814 DUST CAP, 2 INCH	2
12	151222 GREASE ZERK, .25 SELF TAPPING	2
13	4420581 PIVOT ARM, HD, LONG	1
14	152225 BOLT, .5 NC x 3, G8	2
15	158006 FLANGE BOLT, .5 NC x 1.75, G5	4
16	158007 FLANGE NUT, .5 NC	4
17	150217 LOCK WASHER, .5	2
18	150060 LOCKNUT, .5 NC, PLTD	2
19	4420309 HD HUB ASSEMBLY □	2
20	DS 4420304 HUB BRACKET, WELDMENT, HD	1
21	DS 4420305 SPINDLE HUB, HD, WELDMENT	1
22	150409 COTTER PIN, .125 x 1.5, PLAIN	1
23	4440814 DUST CAP, 2 INCH	1
24	151222 GREASE ZERK, .25 SELF TAPPING	1
25	4440817 RACE	2
26	4440816 BEARING	2
27	4440815 SEAL	1
28	158012 SPINDLE WASHER, .75	1
29	158002 SLOTTED NUT, .75 NC THIN	1
30	DS 4440785 BLADE, 18 INCH NOTCHED	1
31	158004 FLANGE BOLT, .375 NC x .75, G5	4
32	158005 FLANGE NUT, .375 NC	4

**** TO REVERSE OFFSET, **
SWITCH 4420581 HD PIVOT ARM, LONG (6) AND
4420303 HD PIVOT ARM (5) TO OPPOSITE SIDES**

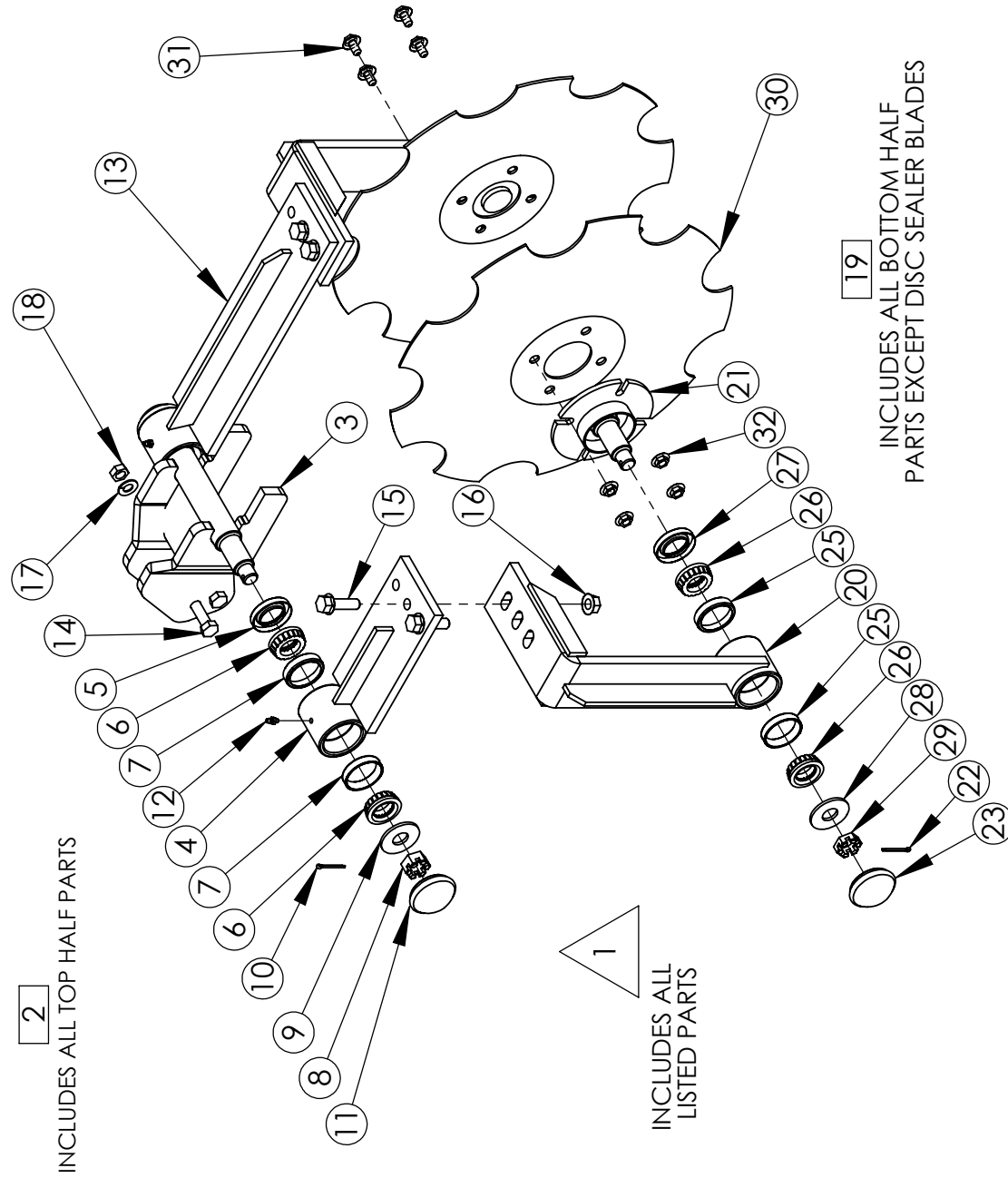

DRAWN BY	RICH SMOTHERS	4/28/2009
CHECKED BY		
PRINT DATE	10/9/2014	
CONFIG:	EXPLODED	
COMMENTS:	<p>PROPRIETARY AND CONFIDENTIAL THE INFORMATION CONTAINED IN THIS DRAWING IS THE SOLE PROPERTY OF DALTON AG. ANY REPRODUCTION IN PART OR AS A WHOLE WITHOUT THE WRITTEN PERMISSION OF DALTON AG IS PROHIBITED.</p>	
DWG:	4410262 OS HCS DISC SEALER, WITH OFFSET ARMS	
SIZE	A	ASSEMBLY
REV	A	
SCALE:	1:8	SHEET 1 OF 1

FOR PARTS, CALL 1.800.342.7498

S1264SL-SPRING LOADED SHANK CLAMP

#	PART NUMBER	QTY.
1	4410218 S1264SL W/O TOP BRACKET AND BOLTS	1
2	SLSC 4420281 SHANK PIVOT	1
3	SLSC 4420280 SPRING GUIDE CAP	1
4	SLSC 4420282 SPRING BOLT WELDMENT	1
5	SLSC 4431072 TOP BRACKET	1
6	SLSC 641480 SPRING	1
7	4440789 U-BOLT, 1.5 x 3 x .5 NC, ROUND HEAD	2
8	150008 NUT, .5 NC, PLTD	4
9	150010 NUT, .625 NC, PLTD	4
10	150013 NUT, .75 NC	1
11	150218 LOCK WASHER, .5, PLTD	4
12	150220 FLAT WASHER, .5 PLTD	4
13	152422 BOLT, .625 NC x 8, G5	4
14	150222 LOCK WASHER, .625, PLTD	4
15	150226 LOCK WASHER, .75, PLTD	1
16	152611 BOLT, .75 NC x 3, G5	1
17	158000 NUT, .75 NF	1
18	158001 JAM NUT, .75 NF	1

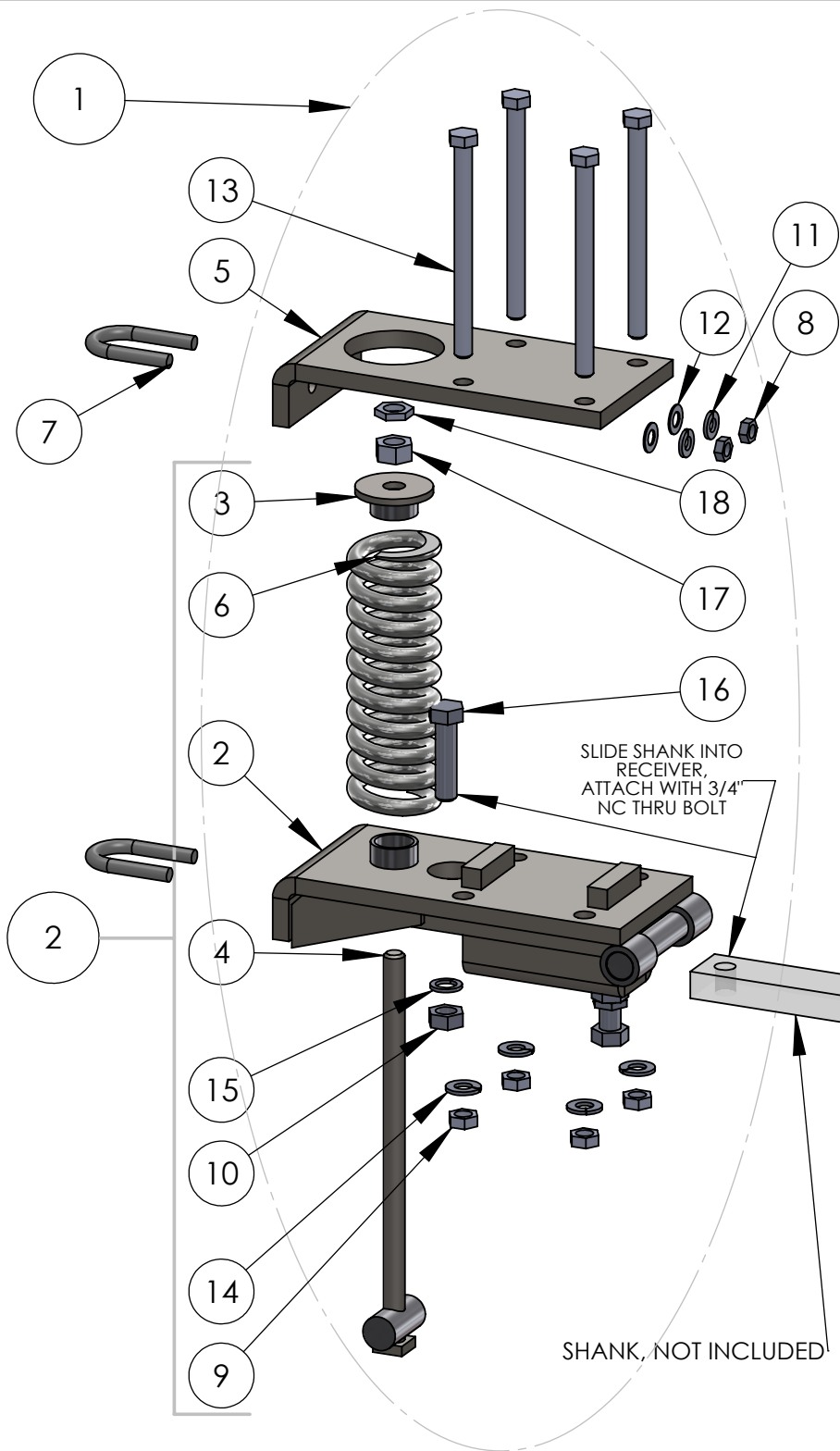

DRAWN BY	RICH SMOTHERS	4/9/2009
CHECKED BY		
PRINT DATE	11/14/2014	
CONFIG.	EXPLODED	



DWG: SLSC S1264SL-SPRING LOADED SHANK CLAMP, CUSTOMER DWG PACKAGE

SIZE	SHEET TITLE:	REV
A	complete ea	A

SCALE: 1:6 SHEET 1 OF 1

PROPRIETARY AND CONFIDENTIAL
THE INFORMATION CONTAINED IN THIS DRAWING IS THE SOLE PROPERTY OF DALTON AG. ANY REPRODUCTION IN PART OR AS A WHOLE WITHOUT THE WRITTEN PERMISSION OF DALTON AG IS PROHIBITED.

FOR PARTS, CALL 1.800.342.7498

S1266SL-SPRING LOADED SHANK CLAMP, 6x6

#	PART NUMBER	QTY.
1	S1266SL SPRING LOADED SHANK CLAMP	1
2	4410246=S1266SL W/O TOP BRACKET AND BOLTS	1
3	SLSC 4420280 SPRING GUIDE CAP	1
4	SLSC 4420282 SPRING BOLT WELDMENT	1
5	SLSC 4420466 SHANK PIVOT, 6x6	1
6	SLSC 4435829 TOP BRACKET 6X6	1
7	SLSC 641480 SPRING	1
8	4440789 U-BOLT, 1.5 x 3 x .5 NC, ROUND HEAD	2
9	150008 NUT, .5 NC, PLTD	4
10	150010 NUT, .625 NC, PLTD	4
11	150013 NUT, .75 NC	1
12	150218 LOCK WASHER, .5, PLTD	4
13	150220 FLAT WASHER, .5 PLTD	4
14	152422 BOLT, .625 NC x 8, G5	4
15	150222 LOCK WASHER, .625, PLTD	4
16	150226 LOCK WASHER, .75, PLTD	1
17	152611 BOLT, .75 NC x 3, G5	1
18	158000 NUT, .75 NF	1
19	158001 JAM NUT,.75 NF	1

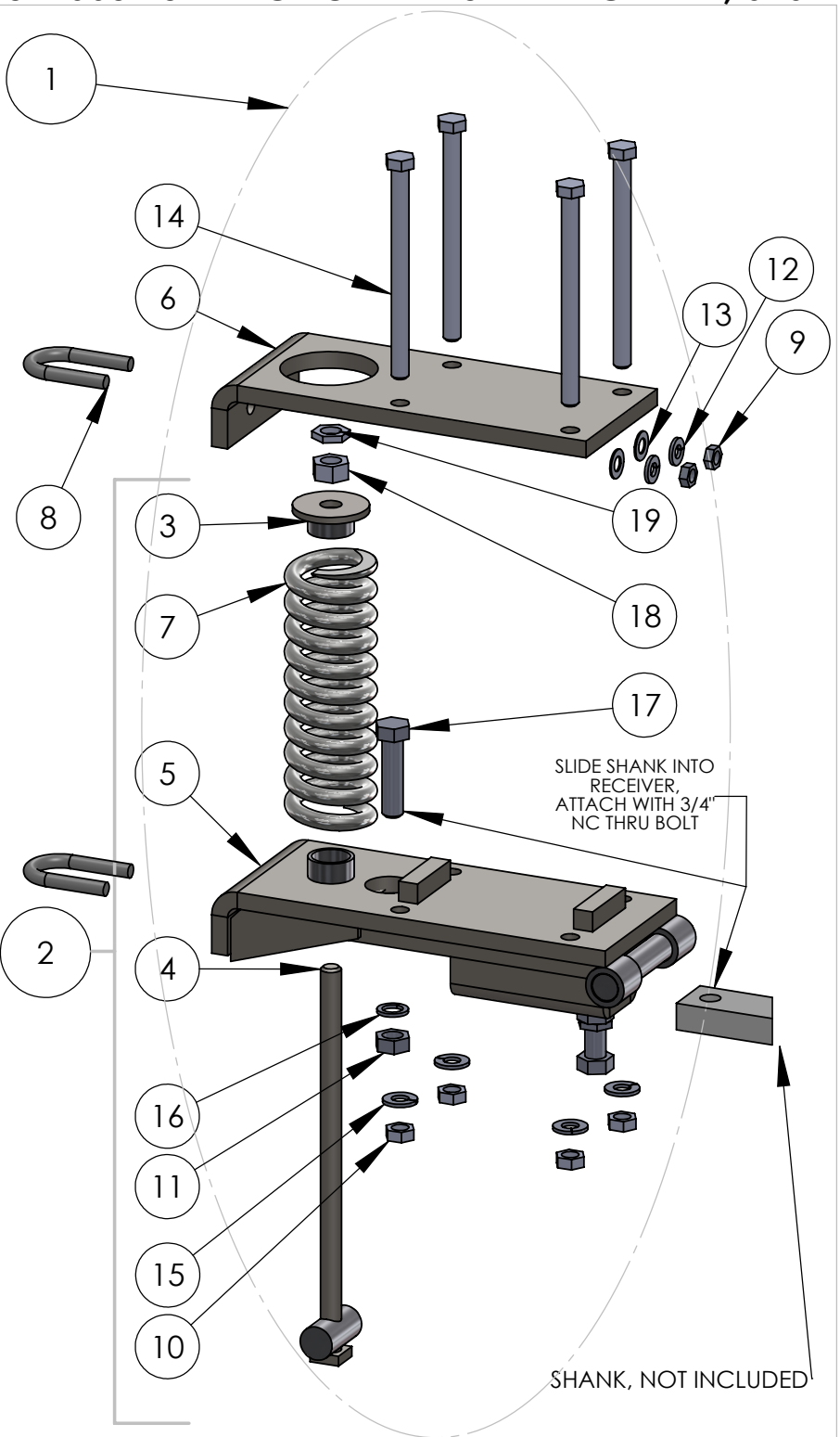

DRAWN BY	RICH SMOTHERS	4/9/2009
CHECKED BY		
PRINT DATE	11/14/2014	
CONFIG.	EXPLODED	



PROPRIETARY AND CONFIDENTIAL
 THE INFORMATION CONTAINED IN THIS DRAWING IS THE SOLE PROPERTY OF DALTON AG. ANY REPRODUCTION IN PART OR AS A WHOLE WITHOUT THE WRITTEN PERMISSION OF DALTON AG IS PROHIBITED.

COMMENTS:

DWG: SLSC S1266SL-SPRING LOADED SHANK CLAMP, 6x6, CUSTOMER DWG PACKAGE

SIZE	SHEET TITLE:	REV
A	complete ea	A

PARTS ORDERING PROCEDURE

When replacement parts are required, consult the applicable illustration and parts list to obtain the correct part name and number. When requesting a replacement part, always include the following information:

1. Complete part number
2. Part name
3. Quantity required
4. Machine and model number
5. Machine serial number—Located on the topside of the frame near the hitch.
6. Provide complete name and address for where and how parts are to be shipped.

NOTE: Right and left hand parts and sides of the units are determined by standing at the rear and facing in the direction of forward travel.

In the event you experience trouble in assembly, operation, or in ordering parts, contact:

Dalton Ag Products
Customer Service Department
Lenox, Iowa 50851

Toll Free: 800-342-7498
Phone: 641-333-4518
Fax: 641-333-4429



www.DaltonAg.com

602 E. VAN BUREN | LENOX, IOWA 50851 | 800.342.7498