

3" HIGH-FLOW DURA-METER™ QUICK ASSEMBLY INSTRUCTIONS

- ① Connect the (2) 9V batteries.
- ② Install 9V batteries into meter body
- ③ Connect paddle wheel circuit
- ④ Apply a small amount of anti-seize on each bolt.
- ⑤ Secure face plate to meter body and ensure you do not pinch any cables
- ⑥ Install the (4) 10-32 bolts and slightly snug to tightness

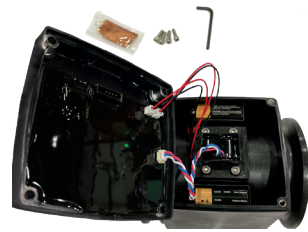
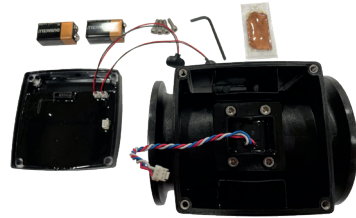

HFM3_Assembly_Installation_030722

3" HIGH-FLOW DURA-METER™ INSTALLATION GUIDELINES

This page details mounting and installation guidelines for the Dura-Meter® High Flow paddle wheel meter. These are location and installation guidelines. This is not a troubleshooting guide for mechanical/electrical issues.

About 95% of the flow metering issues are traceable back to the following 5 simple principles.

- ① **THE FLOW RATE MUST BE WITHIN THE RECOMMENDED RANGE FOR THE PIPE SIZE THE METER IS INSTALLED ON.**

All flow meters all have a minimum flow rate they will measure for each pipe size. No flow meter reads down to 0. This lower limit is a result of the flow velocity not containing enough momentum to keep the paddle wheel spinning. At some point the flow velocity drops and the paddle no longer spins linearly with respect to the flow rate. This is the lowest flow rate the meter can accurately measure. The meter may indicate flow rates below this value but will contain a large inaccuracy. At some point the flow velocity becomes too low and the meter will indicate 0, even though there is still flow.

The bottom line – if you don't have an adequate flow rate you need to either reduce the pipe diameter or find a different flow meter. You won't get satisfactory results trying to monitor flows below the recommended minimum value.

- ② **THE PIPE MUST BE FULL OF FLUID AT ALL TIMES**

The pipe must be completely full of liquid! This is particularly an issue when the meter is installed on pipes that have a downward flow direction. Vertical pipes with a downward flow are the most prone to this issue. Huge flow variations can be noted on the meter if the pipe isn't full. On horizontal runs with partially filled pipes the results will be either no flow reading if the paddle isn't in the flow path due to the meter paddle wheel being mounted on top of the pipe, or readings that are mysteriously high or erratic. If keeping the pipe fluid full is a challenge, a partially closed valve downstream will restrict the flow and keep the pipe full.

- ③ **THERE MUST BE A SUFFICIENT LENGTH OF STRAIGHT PIPE BEFORE AND AFTER THE METER.**

To develop a uniform flow profile in the pipe, a sufficient straight section of pipe must be both upstream and downstream of the meter. The diagram is a general idea of necessary lengths of pipe needed to develop uniform flow and get accurate results from the flow meter.



If an adequate run of straight pipe isn't possible, a reduction in accuracy may result. Typically the error is uniform (linear) across the flow range. **The flow rate can be determined by meter calibration, the flow meter can be adjusted for repeatability and thus accuracy. The instruction manual illustrates methods for calibration.**

- ④ **INSTALLATION OF METER WITH HORIZONTAL OR VERTICAL PIPE**

Install flow meter at the location where the pipe is filled with liquid.

A. Horizontal Pipe
optimal option:

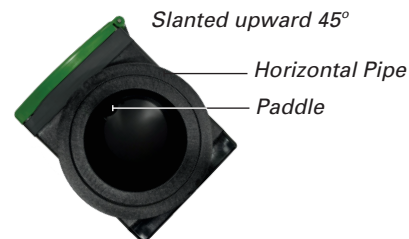

B. Vertical pipe
optimal option:



- ⑤ **THE FLUID ENTERING THE METER MUST BE FREE OF DEBRIS.**

A filter should be installed before the flow meter to lengthen service life and improve measurement accuracy. The filter should be installed before the flow meter to remove impurities or foreign objects from the fluid that can interfere with the mechanical components.

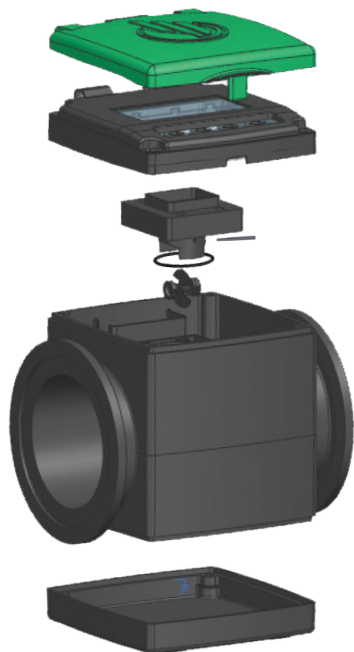

HFM3_MeterManual_021522

3" HIGH-FLOW DURA-METER™

The meter will turn **ON** with any button press or when fluid passes through the meter. It will turn **OFF** when not in use.

Use buttons to navigate the four main menus; **Reset, Program, Calibration, Info.** The buttons correspond to the on screen indicators.

(2) 9 Volt batteries provide about 35 hours of use with the backlight turned **ON**. Battery life is extended with the backlight **OFF**.

TECHNICAL SPECIFICATIONS	
Nominal Size	3"
Model	DP-HFM3
Connection	M300 flange
Meter Accuracy	+/- 0.5%
Non-conductive Fluids	Yes
Fluid Flow Initiates Measurement	Yes
Batteries	(2) 9 Volt
Battery Life Indicator	Yes
Backlit Display	Yes
Maximum Pressure	150 PSI
Minimum GPM	15
Maximum GPM	700
Minimum Temp	+ 32 °F
Maximum Temp	+ 140 °F
Battery Size/Voltage	9V
Meter Type/Style	Paddlewheel
Body Construction Material	GF Polypropyl
Paddle Bearing Construction Material	Sapphire
Minimum Straight Inlet Required *	7" *
Minimum Straight Outlet Required *	7" *
Field Calibration Capability *	Yes *
cP Viscosity Range	0-50 Centipoise

* Meter has been pre-calibrated for water with 30" Inlet and 15" Outlet plumbing. Fluid other than water and/or plumbing options can achieve +/- 0.5% accuracy through meter calibration.

CALIBRATION

NOTE: Use a primed system. Verify your calibration. Fluid viscosity changes with temperature.

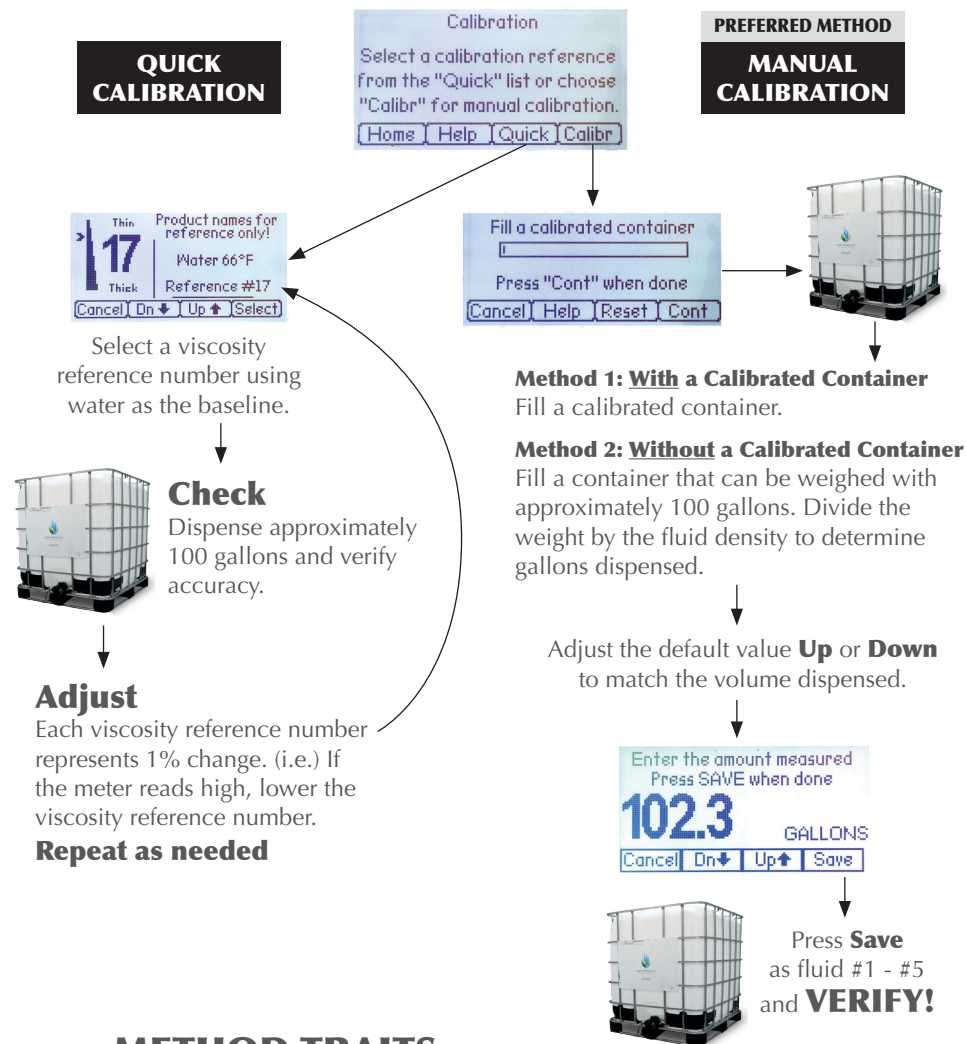

METHOD TRAITS

QUICK CALIBRATION	MANUAL CALIBRATION
/ Great for fleet use	/ Most accurate
	/ Usually only takes one attempt
	/ Adjustable to compensate for different measurement containers