



WWWW25-P

[User Manual]

Please read and follow the installation and operating instructions provided.

Table of Contents

- I. **Introduction** 1
- II. **Installation Instructions** 2
 - Step #1 Lay out your frame
 - Step #2 Connect left and right frame to tank stand assembly
 - Step #3 Connect toolbar to right and left wings
 - Step #4 Attach hitch to tank stand assembly
 - Step #5 Attach interior wheel legs and wheels
 - Step #6 Attach exterior wheel legs and wheels
 - Step #7 Attach wing braces to tank stand assembly
 - Step #8 Attach the tank
 - Step #9 Saturate your sponges
 - Step #10 Secure one t-riser to your toolbar
 - Step #11 Connecting the sponge section to the t-riser
 - Step #12 Secure the rest of your t-risers and sponges
 - Step #13 Mounting your manifold
 - Step #14 Plumbing your weed wiper
 - Step #15 Check valve & filter assembly
 - Step #16 Installing the electrical wire harness.
- III. **Operating Instructions**14
 - Before you start
 - Mixing instructions
 - Field adjustments
 - Folding wings for road or trailer position
- IV. **Maintenance Requirements**.....17
 - Common filter maintenence
 - Operating at freezing temperatures

IMPORTANT:

YOUR SMUCKER WEED WIPER COMES WITH A 2 YEAR MANUFACTURES WARRANTY. PLEASE SAVE YOUR RECEIPT FOR PROOF OF PURCHASE. CONTACT THE DEALER THAT YOU PURCHASES YOUR WIPER FORM WITH ANY WARRANTY ISSUES.

INTRODUCTION

Congratulations on your purchase of a Smucker Super Sponge® Weed Wiper!

The Super Sponge® is a lightweight, durable, herbicide applicator. Our sponges are designed to apply the maximum amount of product to the target weeds without any drift. The sponge applicators are made of industrial-strength, crusted sponge that stay saturated with chemical to wipe directly onto weeds. Our sponge weed wiper and top crop kits are applicators. Smucker Manufacturing makes no guarantee of any and all chemical use through the sponge application. Please read all chemical labeling concerning the weed wiper instructions.

The Super Sponge® has proven to be a quick and efficient way to wipe out weeds in your crops in many independent studies and we are confident you will be pleased with the results. We value our customers, and we would appreciate any input or comments you may have regarding your new Super Sponge® wiper.

You can visit our smuckermfg.net website page for reference to all weed wiper parts and diagrams. If you still have questions, give us a call and we can even help you locate your closest Smucker dealer.

Also, visit www.smuckermfg.net or ask your dealer about the other product lines we offer. We offer premium products at an affordable price. Take a look at our Foam Markers, Calf Warmers, and VisionWorks camera systems for farm equipment on our website.

www.smuckermfg.net

www.redweeder.com

www.visionworkscameras.com

Scan QR codes below with your smart phone

Mobile website for VisionWorks Cameras



Smucker Mobile website



22919 N. Coburg Rd.
Harrisburg, OR

smuckermfg.net

Installation Instructions

Thank you for purchasing a Pull-Type Weed Wiper. Please follow these directions carefully. We recommend assembling this unit with two people. You should expect a 1-1 ½ hour assembly time.

Please refer to your, “Part Pull Sheet” when installing your Weed Wiper.

Step #1 Lay out your frame

Lay out the metal frame on the ground in conjunction to the images below. Notice that the wings are being placed with the wheel leg adjuster facing up and the angle iron mounting brackets facing the hitch at the front of the unit (They also have a sticker to indicate the left and right wing). The interior wheel legs are universal and are interchangeable on the right and left side. However, the exterior wheel y-legs are specifically designed for either the right or left side (Check stickers when laying out your model).

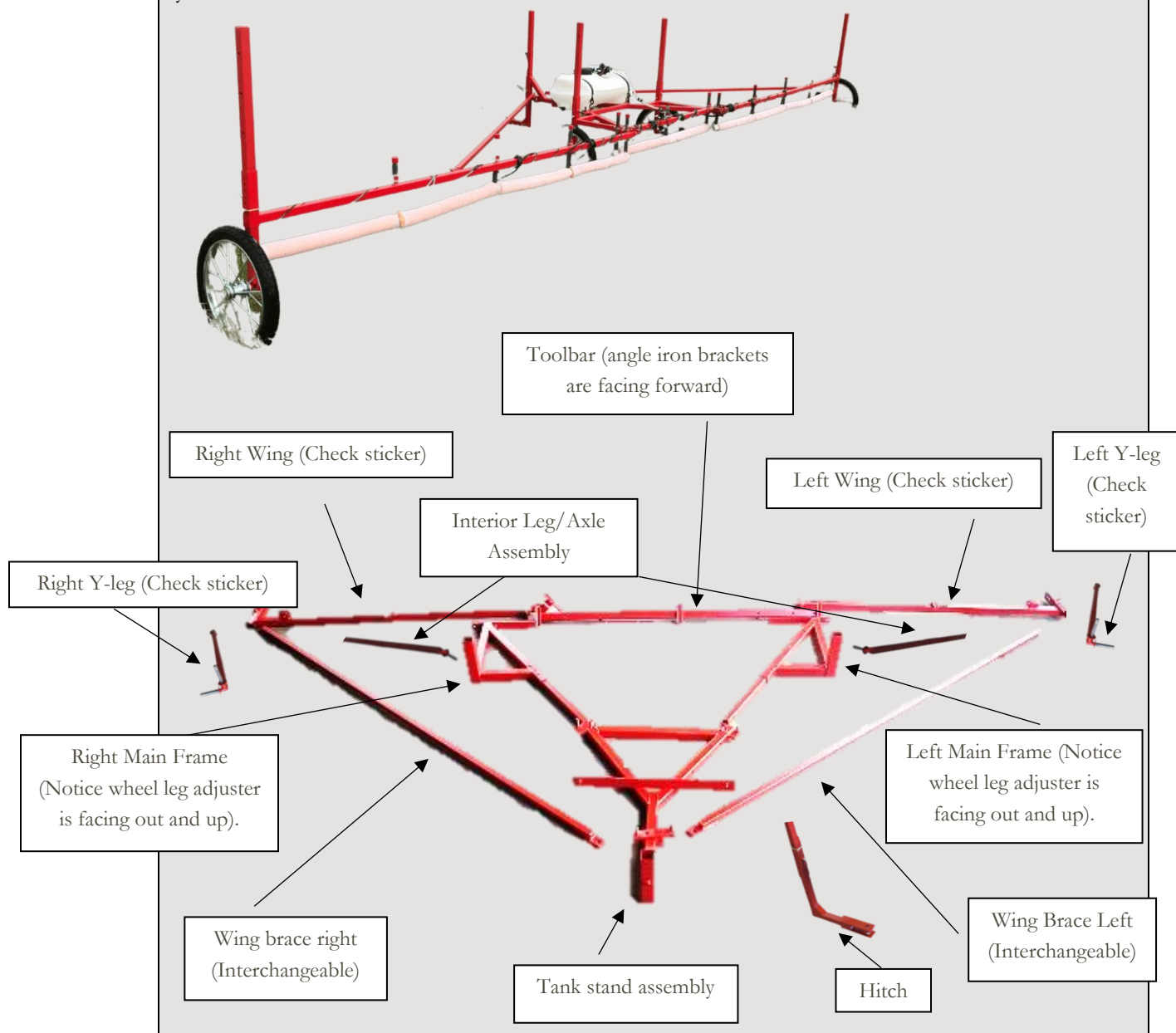

Step #2 Connect left and right frame to tank stand assembly

Insert your main frame left and main frame right into the tank stand assembly. Make sure when inserting your brackets that the wheel leg adjusters are sticking up (as pictured). Secure your frame members with the 3/8" x 2" bolts provided (NB3820 QTY: 4) with the 3/8" lock washers (NB38LO QTY: 4) and 3/8" nuts (NB38NU QTY: 4) provided. **Do not over tighten these bolts.**

NB3820



NB38NU



NB38LO

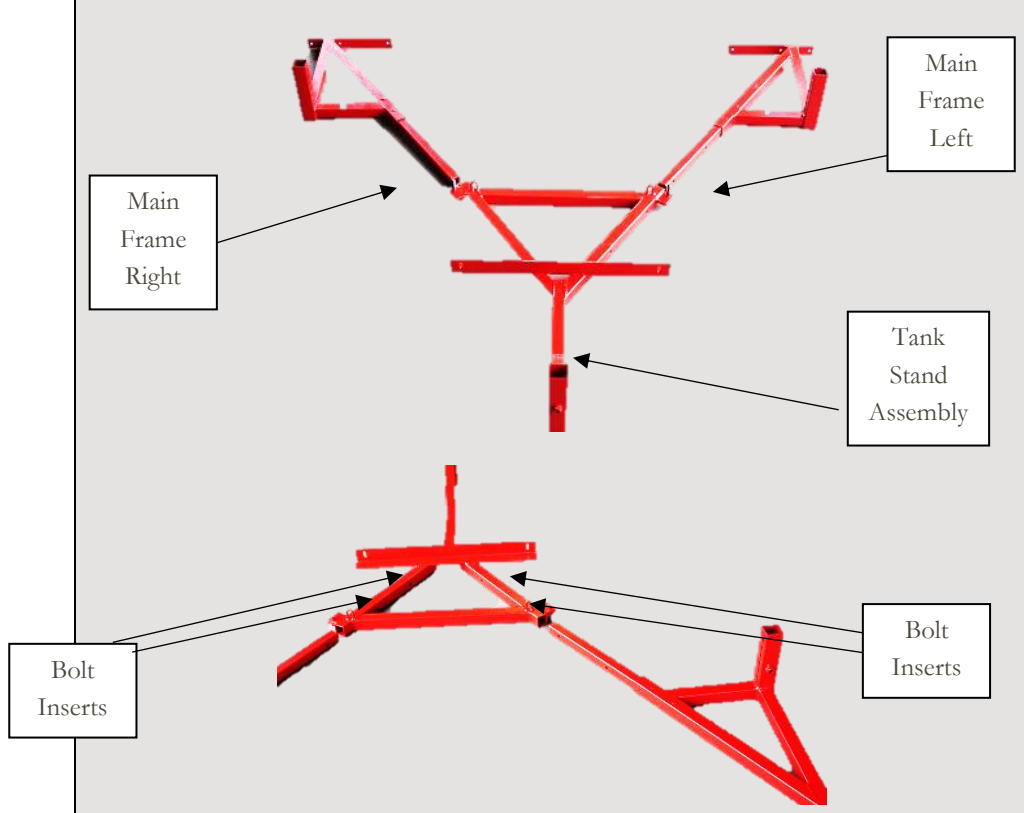

Step #3 Connect toolbar to right and left wings

Secure your toolbar to the back of your right and left frame with 3/8" x 3" bolts (NB3830 QTY: 2), 3/8" lock washers (NB38NU QTY: 2) and 3/8" nuts provided (NB38LO QTY: 2). Use one bolt for each side and make sure the angle iron brackets are facing forward towards the tank stand assembly.

NB3830



NB38NU



NB38LO

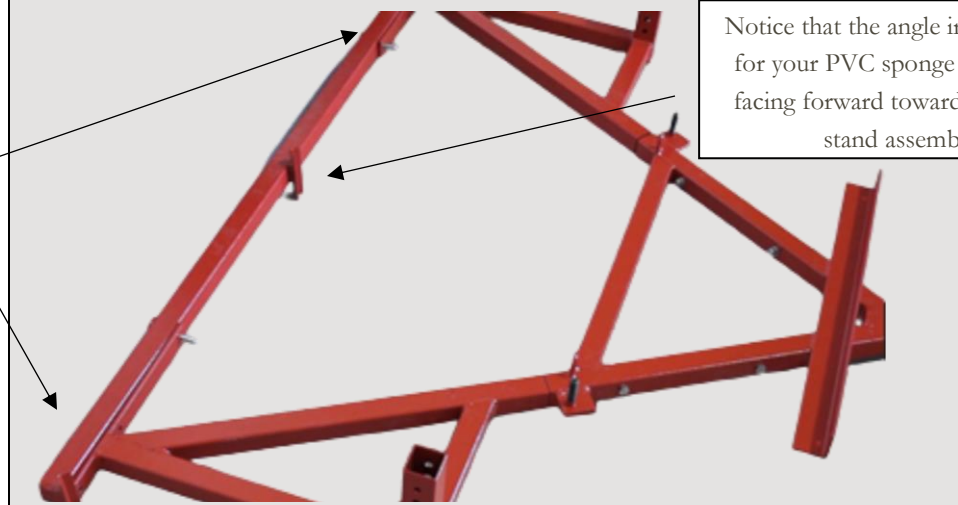

Step #3 (Continued)

NB3830



NB38NU



NB38LO



Right Wing (labeled with a sticker)

Then, attach the right wing (labeled with a sticker) with the 3/8" x 3" bolts (NB3830 QTY: 4), 3/8" lock washers (NB38LO QTY: 4) and 3/8" nuts (NB38NU QTY: 4) by running them through both the toolbar and right and right main frame. Repeat steps for the left wing (labeled with a sticker) and left main frame.

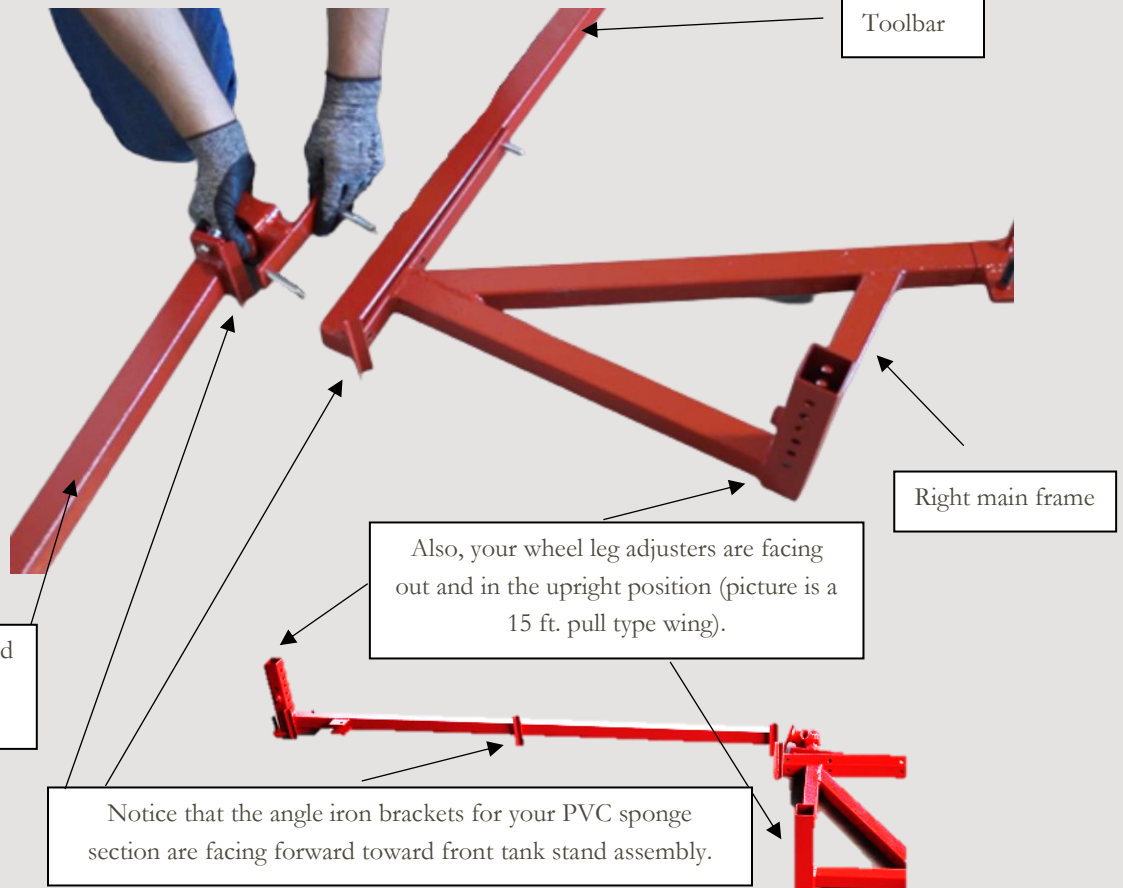

Before tightening, make sure your welded mounting brackets and the wing brace bracket slot are facing forward towards your hitch. Additionally, the wheel bracket should be facing up. Checking these things will ensure you have attached the correct wing to the right side of your assembly.

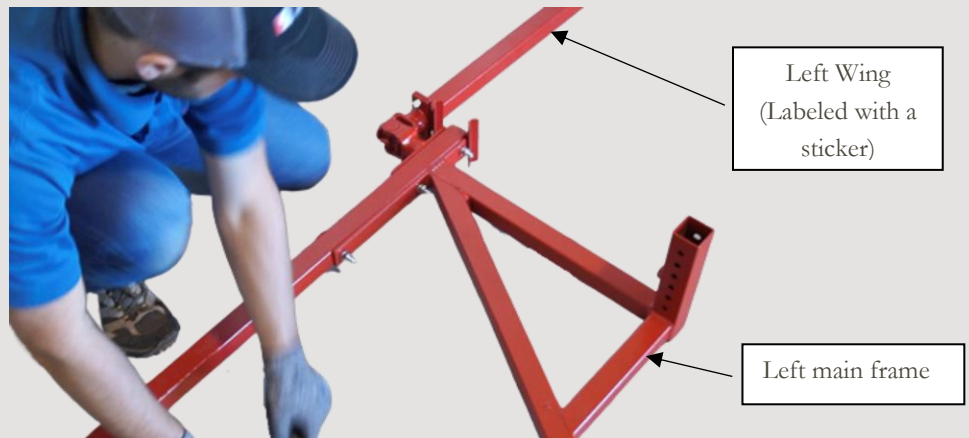

After checking these steps, secure your bolts with two 9/16" wrenches and repeat steps for the left side wing. **Do not over tighten.**

Step #4
Attach hitch
to tank
stand
assembly

Carefully lift your weed wiper frame and slide the hitch into the assembly with the hitch connector facing forward. Secure your hitch with the PTO pin provided (WW2520 QTY: 1) at the preferred height of the weed wiper. During assembly, you don't need to worry about the height since you can always come back to your model later when you are in the field and adjust the height by removing the pin and lowering your weed wiper to your desired height.

WW2520



NB5012



NB50NU

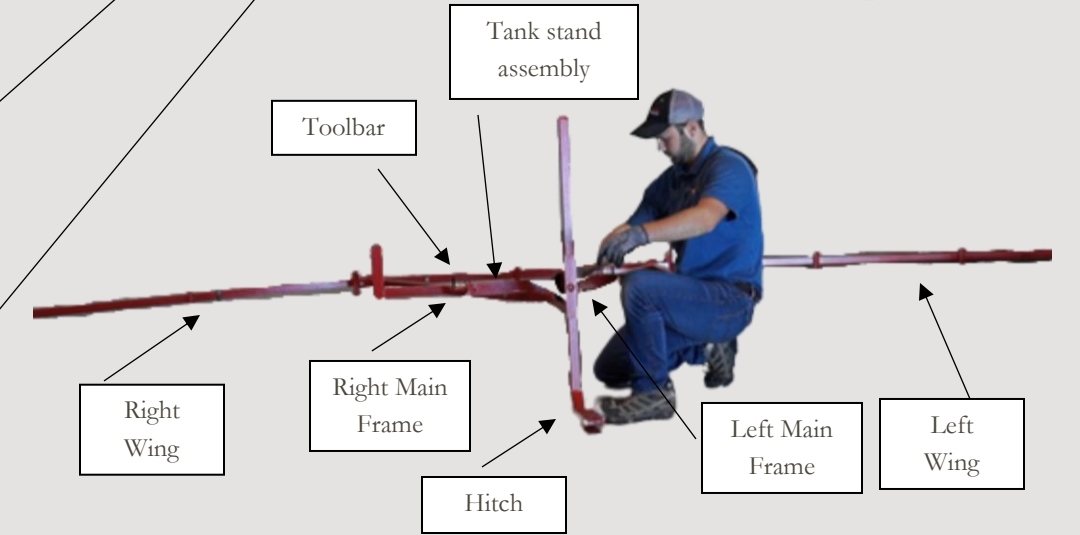

After securing the pin, secure the hitch by placing the 1/2" by 1 1/4" bolt (NB5012 QTY: 1) and 1/2" nut (NB50NU QTY: 1) in the socket of the hitch. This is necessary to remove rattle and sway when driving the machine at higher speeds

#5 Attach interior wheel legs and wheels

To attach the wheel legs, you will need to lift and rest your metal assembly against a wall. This will allow you to slide in the wheel legs without the assistance of another person. Insert the wheel legs and attach them with the axel pins (NM1316 QTY: 1 per wheel) provided.

Wheel legs



WW2520



NB75FL



NM1316

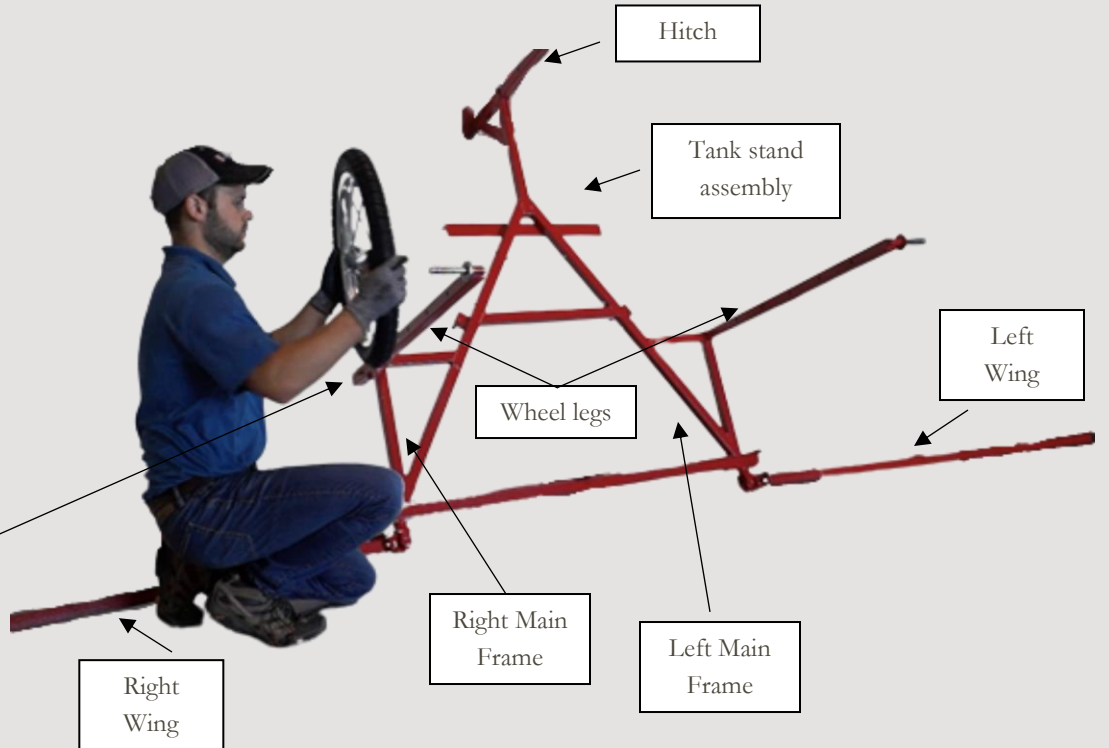

Secure your wheel to the wheel leg by placing one 3/4" washer (NB75FL QTY: 3 per wheel) on the wheel axle, then the wheel and up to two more 3/4" washers (NB75FL QTY: 3 per wheel) depending on your assembly. Place interior pins (NM1316 QTY: 1 per wheel) in the assembly in the downward direction and bend the pins as shown.

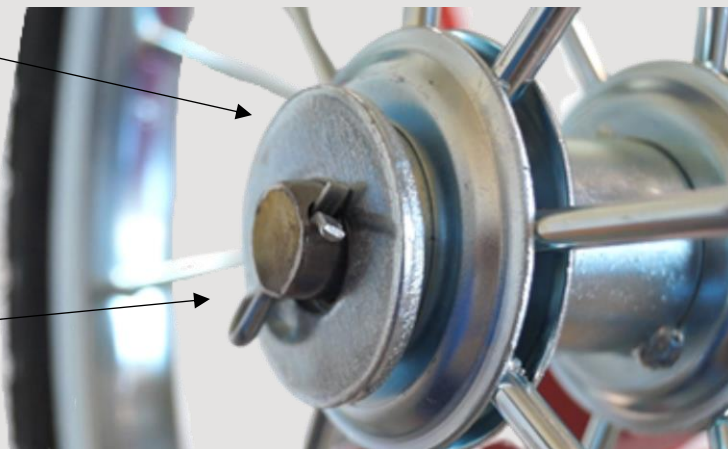

Repeat steps for the left wheel leg and wheel.

Step #6
Attach
exterior
wheel legs
and wheels

To attach your left exterior wheel legs, you must first make sure that when you slide in your y-leg and secure it with the PTO pin (WW2520 QTY: 1 per wheel), that one axle faces out and the other points towards the back of the unit if the weed wiper was running through the field (left and right y-legs are also labeled). This y-leg allows users the ability to fold the unit into roadside position.

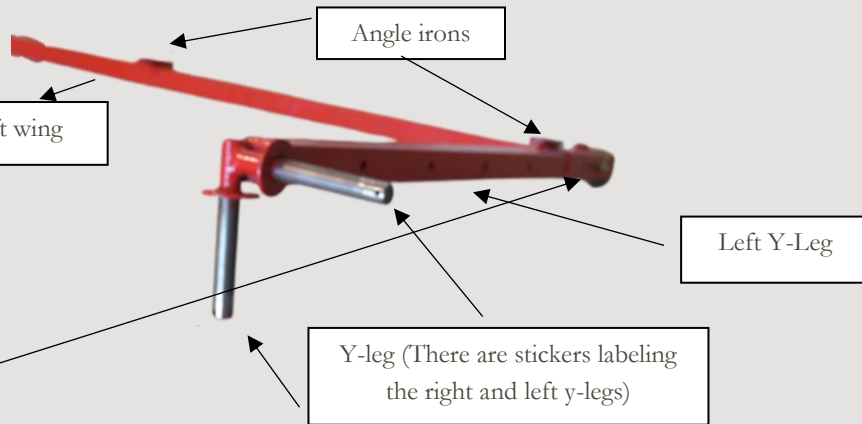

Pictures shown show the weed wiper resting up against the wall still.

WW2520



Again, you will place one 3/4" washer (NB75FL QTY: 3 per wheel), the wheel, and up to two more washers (NB75FL QTY: 3 per wheel) on the axle before securing it with the exterior snap lock pin (WW4006 QTY: 1 per wheel) pointed in the downward direction.



NB75FL



WW4006



Repeat steps for the right exterior wheel leg and then you can pull the assembly off the wall and stand it up, so the wheels are on the ground. Secure all wheel legs by placing the 1/2" by 1 1/4" bolt (NB5012 QTY: 1 per wheel) and 1/2" nut (NB50NU QTY: 1 per wheel) in the socket of the main frames and the wings. This is necessary to remove rattle and sway when driving the machine at higher speeds

NB5012



NB50NU

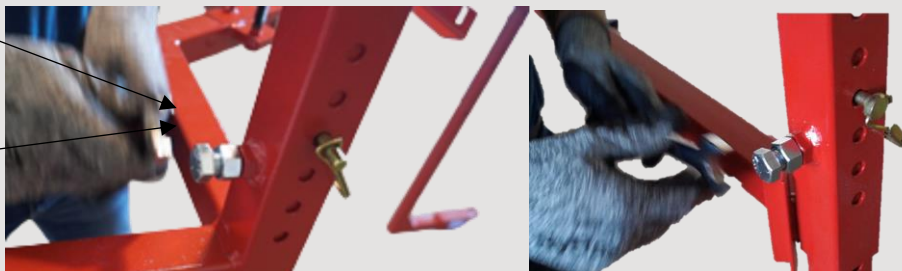

Step #7 Attach wing braces to tank stand assembly

Start by attaching the tank stand wing brace bracket pieces to your tank stand assembly in the position shown with two 3/8" x 3" bolts (NB3830 QTY: 2) and 3/8" nylock nuts (NB38NI QTY: 2). Do not fully secure the tank stand wing brace bracket yet.

NB3830



NB38NI



NB50NU

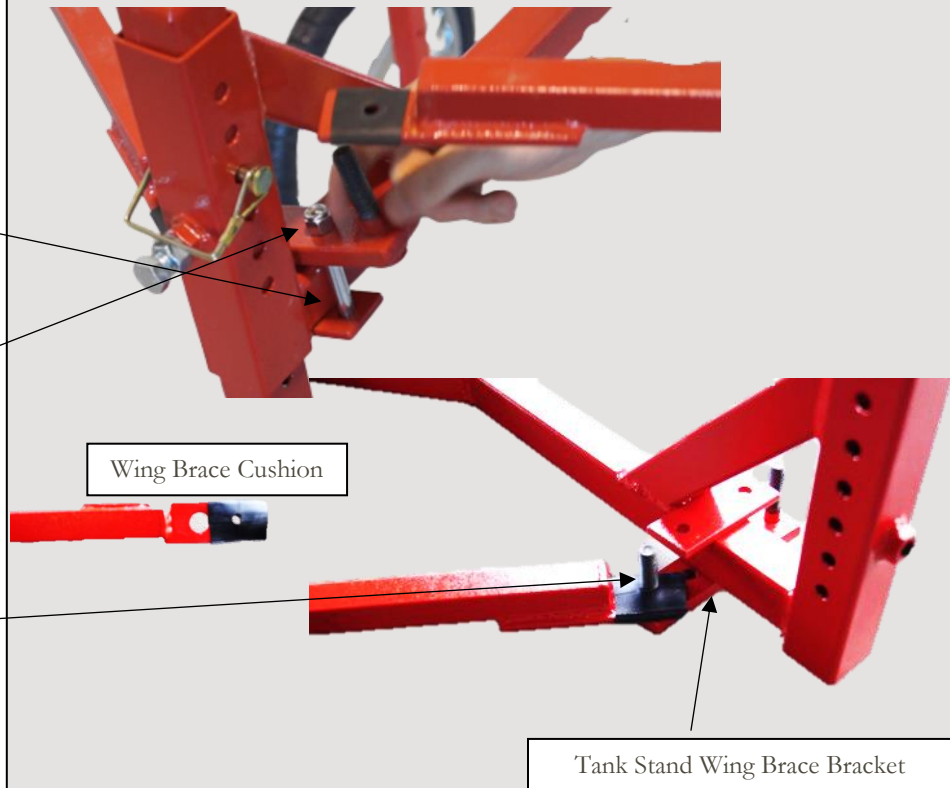

Wing Brace Cushion

Tank Stand Wing Brace Bracket

Attach your wing brace to the tank stand wing brace bracket by placing a wing brace cushion (WW2534 QTY: 2 per wing brace) over the wing brace and then hand tighten two 1/2" nuts (NB50NU QTY: 2 per wing brace stacked on top of each other). Then, attach the other side of your wing brace to the welded wing side brace bracket by placing a brace cushion over the wing brace and then use a PTO pin (WW2520 QTY: 1 per wing brace) to secure it to the wing.

WW2520

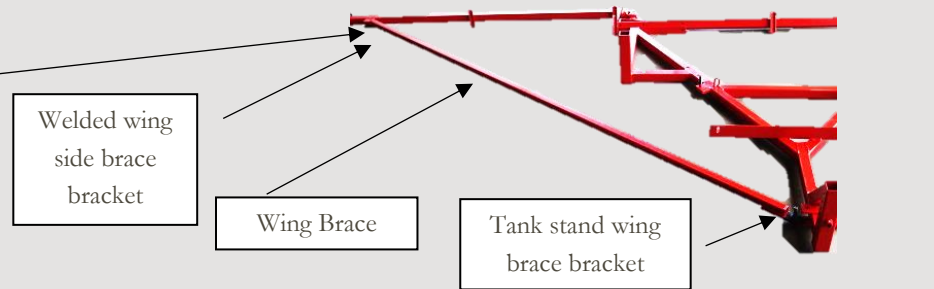

Welded wing side brace bracket

Wing Brace

Tank stand wing brace bracket

Repeat these steps for the opposite side wing brace and then secure the tank stand wing brace bracket once the wing braces are attached.

At this point, you will want **to make sure that all nuts and bolts are secured but not over tightened**, and you can adjust the height of your weed wiper by adjusting the wing legs and hitch to your preferred height.

Step #8 Attach the Tank

Attach the tank and pump assembly (SPS014-WW) with tie down straps as pictured (SPS002).



Step #9 Saturate your sponges

Get your sponges wet with a garden hose and then squeeze out excess water. This step will make it a lot easier to move the sponges during assembly.

Step #10 Secure t-riser to your toolbar

Secure one PVC t-riser (WW2346-TC) to the angle irons on the toolbar with two clamps (CL0016). **Moving forward it will be easiest to work from left to right**, when facing your toolbar angle irons, as shown in the photos below. **Make sure the blue line is facing forward in the wiping direction.**

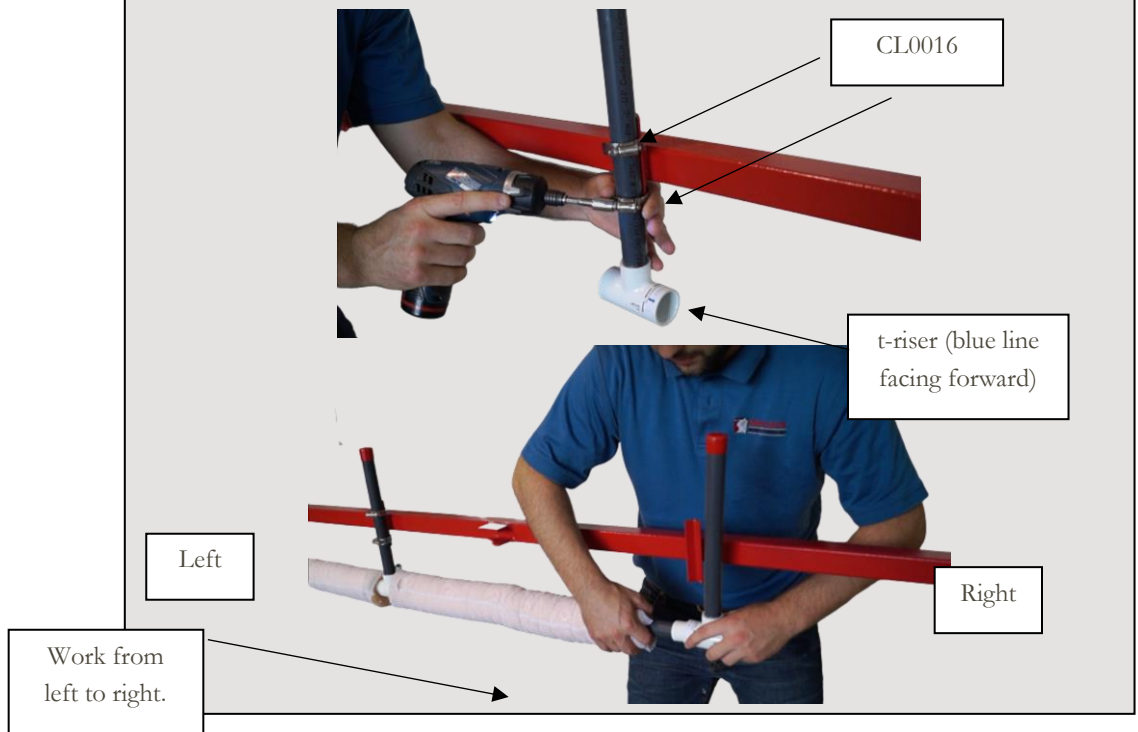

Step #11
Connecting the
sponge section to
the t-riser

Use a mallet hammer to attach a 30” sponge section (WWTC30) to the PVC t-riser (WW2346-TC) you just clamped in and **make sure the blue lines shown below are lined up**. This will ensure that the precision drilled holes on the PVC are angled in the one o’clock position in the wiping direction.

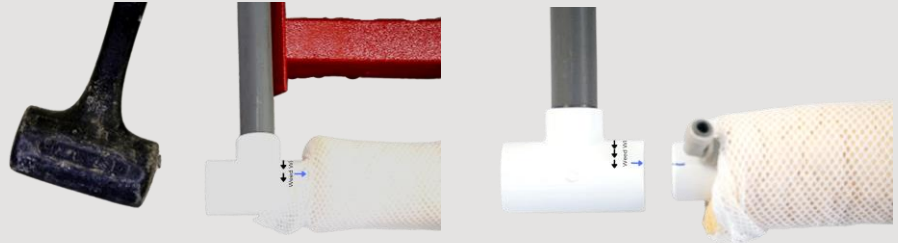

Hammer the sponge white caps into the t-risers **until the edge of the white cap reaches the center of the t-riser**. Remove the red cap after hammering and shine a flashlight through the riser to make sure your cap has reached the center of the t-riser as shown below.

Inside of PVC t-riser when you remove the red cap.

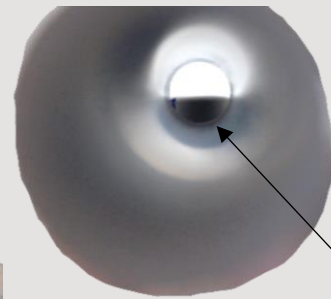
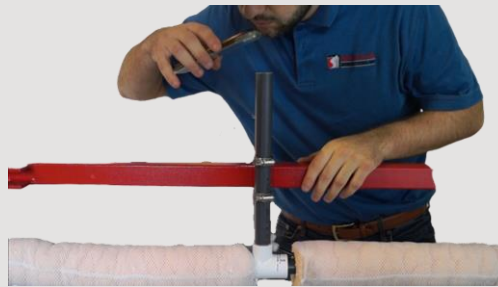

Edge of white cap should be in the center of the t-riser

IMPORTANT: DO NOT glue your sponge sections into your PVC t-risers. You can pull back your sponges to confirm that the precision drilled holes are pointing in the same direction as shown below.

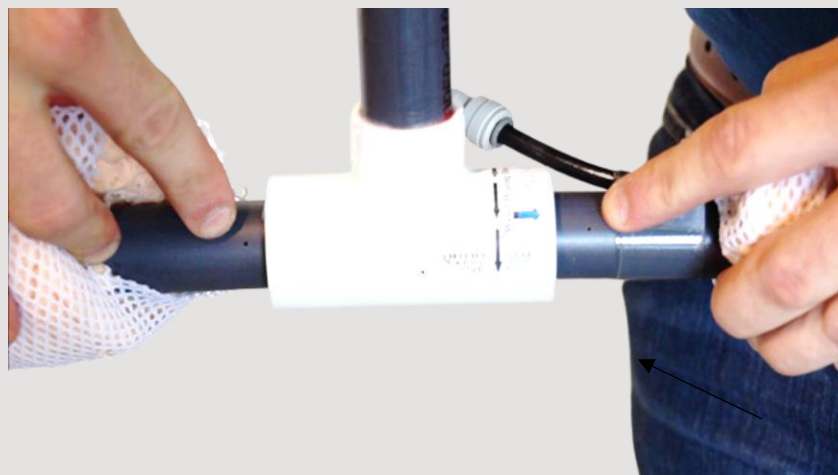

Step #12 Secure the rest of your t-risers and sponges

Working from left to right, repeat steps #10 and #11 until you run out of sponges and t-risers. This unit will have **three separate sponge booms that are not connected continuously by t-risers** (5 t-risers 4 sponges in the center and 4 risers and three sponges on each wing). Please note that it is okay to end your boom with a t-riser since there is no chemical flow through the t-risers. Make sure all push to connect elbows are facing the same direction.

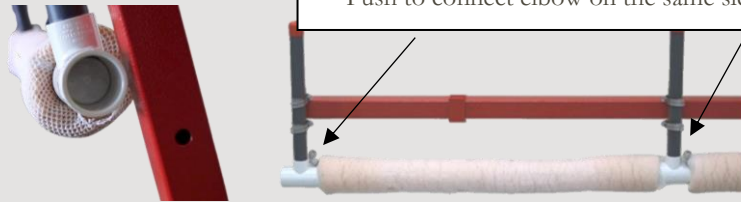

Additionally, make sure that you clamp each t-riser at the same height to ensure that your sponge boom is level. After finishing these steps, make sure you stretch your sponge out over the t-risers so that your boom is almost entirely covered by your sponges.

Notice the t-risers are attached in the same spot to ensure a level sponge boom.



Stretch sponges out over the t-risers

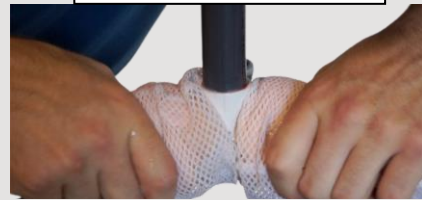

Step #13 Mounting your manifold

Your kit comes with a manifold system (WWTCM10P) which connects to the tank's pump. First, mount the manifold to the **CENTER** of your boom frame (i.e. the center of your weed wiper) with the zip ties provided. **If you do not mount to the center of your boom frame, the tubing included in this kit will not reach all your sponges.** Note the manifold in the pictures is a 4 port, yours is a 10 port.



Step #14
Plumbing your
weed wiper

Run the 3/8" vinyl tubing needed from your pump on your tank to the manifold and use the 9/16" (CL0916) clamp to secure the tubing. As you run the vinyl tubing out to your check valve on your manifolds, coil up the tubing when necessary and secure the tubing with the 9/16" clamp

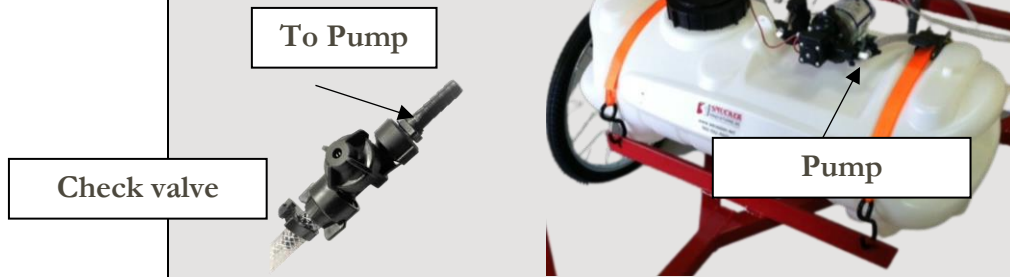

The manifold included has quick connectors to supply product to each of the 30" sponge section (in this case there are 10 ports). Measure your longest line and cut your WW1215 roll in equal lengths, to plumb from your manifold to your individual sponge sections. **It is extremely important that each sponge assembly is supplied with the same length of tubing to ensure equal chemical flow.**



Coil your excess tubing around your boom. Secure with zip ties

Simply push the tubing into the quick connectors on both your sponge section, and your manifold (as shown above). Any extra tubing can be coiled up and zip tied down to the boom. Do not over tighten the zip ties and pinch the tubing. **Note the manifold in the pictures is a 4 port, yours is a 10 port.**

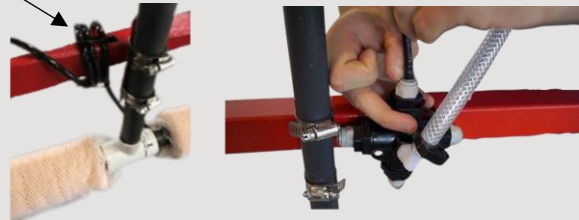

To remove the tubing hold down the grey ring around push to connect, while pulling out the tubing.

Step #15 Check valve & filter assembly

To Weed Wiper

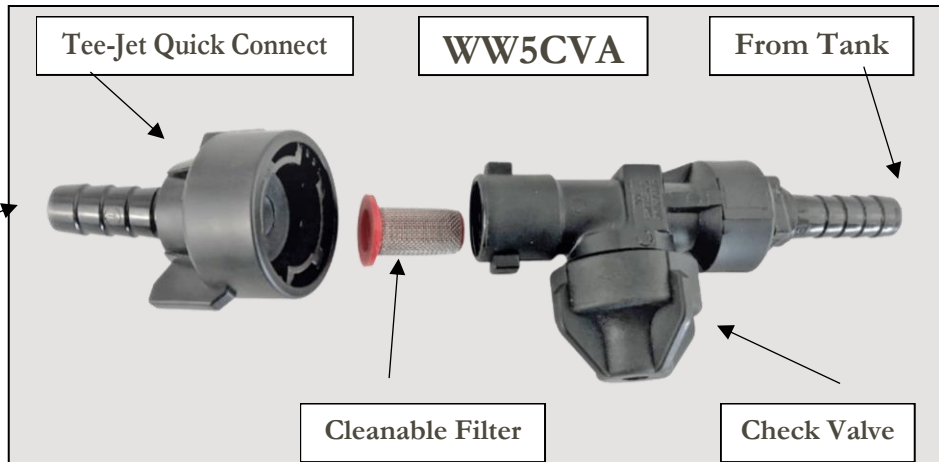

This assembly comes pre-installed to the inlet side of the manifold.

Make sure that you have a way to turn the pump on and off. You will not be running the pump continuously while using your weed wiper. When the pump is on, chemical will be pumped into the PVC, then through small holes saturating the sponges. This pump fed system will ensure quick filling and instant shut off since the system is pressurized.

Maintenance/Winterization

We recommend routinely checking your cleanable filter. The holes feeding the sponges are very small, they can plug easily without a functioning filter. When you **WINTERIZE** your wiper, remove your tee-jet quick connect and blow shop air toward the sponges to remove any residual liquids.

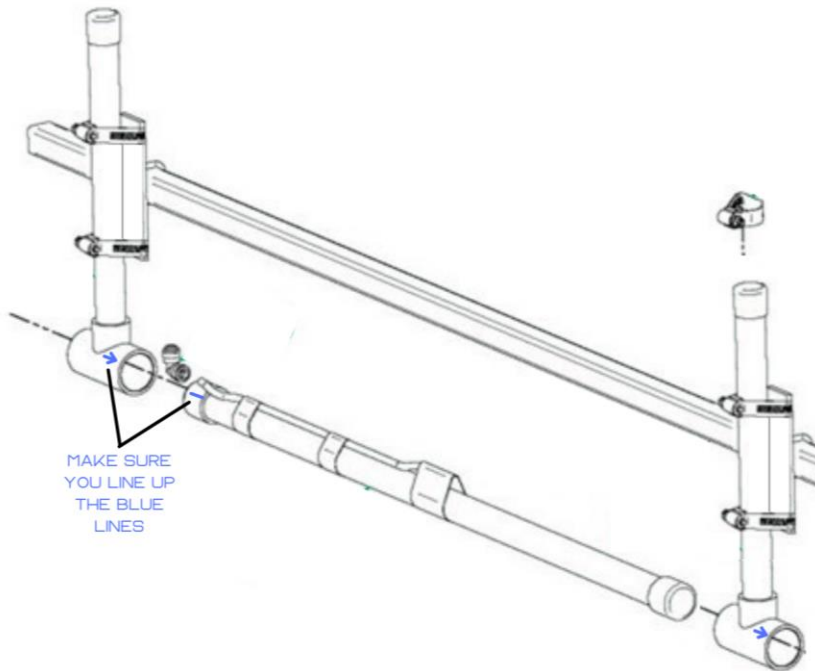

Step #16 Using the weed wiper with your sprayer & installing electrical wire harness

Install the wire harness (SPS117) according to the instructions included with the wire harness. Then, mount the switch in a position that can be reached by the operator.

When the pump is on, the chemical will be pumped into the PVC, through small holes, and into the sponge. This pump fed system will ensure quick filling of the sponges and instant shut off when switch is turned off.

Operating Instructions

The Weed Wiper is a very effective contact herbicide applicator. Non-selective herbicides can be applied to weeds growing above crops. Proper set-up, adjustment, operation, and maintenance are essential to assure effective weed control while protecting the crop from herbicide damage.

Before you start

1. Before you start using your sponge weed wiper in the field, get the sponges wet with a garden hose. When sponges are dry, they are hard and do not absorb chemical evenly.
 2. Next, we recommend that you run water through your tank to check your sponges for even feeding. Before filling the tank with chemicals, put water in your tank and turn on the pump until you see the sponges dripping. Watch for even dripping throughout the full length of the boom. Unlike a conventional sprayer, you cannot see plugged nozzles on a wiper during operation. Always check for uniform feeding before heading out into the field.
 3. Once even feeding is attained, drain your product tank by removing the 3/8" supply tubing from the check valve assembly. Run your pump till the tank is empty. Squeeze the excess water from the sponges and fill the tank with chemical solution. Turn on your pump until you see the sponges fully saturated (almost dripping), which typically will only take a few seconds. Once your sponges are saturated, you are ready to go weed wiping!
-

Mixing instructions

The most common product to use in a wiper is Glyphosate. The manufacturing label recommends a 33% mix rate, however, please follow **your** label for mix rates in a wiping applicator/contact herbicide applicator. It is important to remember that the ratio of herbicide to water can vary depending on the weeds to be controlled, the time of year, and the temperature. Contact your chemical field representative or extension service for the best herbicide mix rates and proper surfactants to kill the weeds you are trying to control.

If you are trying to control Glyphosate resistance weeds, you may want to consider using Paraquat. The label, in most states for controlling Palmer Amaranth, is listed at a 50% mix rate.

Field adjustments

Adjust the height of the sponges to a level just above crop to contact as much of the weed as possible, without wiping the crop.

Turn on the master on/off switch only when you believe that you need more chemical, the sponges should fill within a few second. Begin wiping at 5-7 MPH. Try to maintain a proper level of product in the sponges without dripping. While you are learning the timing for turning the pump on and off, it's usually better to set the wiper too wet and have a little dripping, rather than have it set too dry and have poor weed kill.

Folding wings for road or trailer position

To put the weed wiper in road or trailer position, the outside wheels will need to be repositioned to the other axels. Simply change the outside wheels to the opposite axle on the Y leg. The wings will then trail directly behind. Fold back wing braces and let them rest on the back wings. You may need to loosen the nuts where the wing brace attached to the nose of the frame to make enough slack to fold them back.



Maintenance Requirements

Common sponge maintenance

The protective netting over the sponge is easy to replace. Therefore, we recommend that you check your sponges often for wear and tear.

If you need your netting replaced, ask us for part number (WW2302). If you need your sponge replaced, ask us for part number (WW2301).

Storage maintenance

Do not store the system over the off-season with chemical in the lines. A film will form on the tubing and can plug the small feedholes within the sponge. Avoid this by flushing your system thoroughly with water at the end of the season. We recommend using a garden hose to rinse the bulk material out of the sponges after every use.

Check and clean the filter within the check valve assembly as needed. At the end of the season, store your weed wiper in a dry place, **out of direct sunlight**.
