

LM-4950 SERIES METERING PUMPS

PARTS AND INSTRUCTION MANUAL



LM-4959 Shown

Price \$10.00

CDS-JOHN BLUE COMPANY

DIVISION OF ADVANCED SYSTEMS TECHNOLOGY, INC.

290 Pinehurst Drive • Huntsville, Alabama 35806

P. O. Box 1607 • Huntsville, Alaabama 35807

Telephone: (256) 721-9090 • FAX (256) 721-9091 • Toll Free: 1-800-253-2583

SAFETY PRECAUTIONS

- **Equipment should be operated only by responsible people.**
- **A careful operator is the best insurance against an accident.**
- **Fill system with WATER first and check output.**
- **Check all valves, fittings, hose clamps, etc. for wear / leaks before admitting process fluid to the system.**
- **Replace hoses when worn, cracked, or if leaking.**

WARNING: USE OF THIS PRODUCT FOR ANY PURPOSES OTHER THAN ITS ORIGINAL INTENT, ABUSE OF THE PRODUCT, AND/OR MODIFICATION TO THE ORIGINAL PRODUCT IS STRICTLY PROHIBITED BY CDS-JOHN BLUE COMPANY. CDS-JOHN BLUE COMPANY RESERVES THE RIGHT TO DENY WARRANTY OR LIABILITY CLAIMS IN ANY/ALL SITUATIONS INVOLVING MISUSE, ABUSE OR MODIFICATION.

THE ORIGINAL INTENT OF THIS PRODUCT DOES NOT INCLUDE USE WHERE THE MAXIMUM ALLOWED SPEED, PRESSURE, OR TEMPERATURE IS EXCEEDED, AND IT DOES NOT INCLUDE APPLICATIONS UTILIZING FLUIDS THAT ARE NOT COMPATIBLE WITH THE PRODUCTS COMPONENT MATERIALS. DO NOT USE THIS PRODUCT WITH FLAMMABLE OR COMBUSTIBLE FLUIDS SUCH AS GASOLINE, KEROSENE, DIESEL, ETC..., AND DO NOT USE IN EXPLOSIVE ATMOSPHERES FAILURE TO FOLLOW THIS NOTICE MAY RESULT IN SERIOUS INJURY AND/OR PROPERTY DAMAGE AND WILL VOID THE PRODUCT WARRANTY. IF IN DOUBT ABOUT YOUR APPLICATION, CONTACT YOUR STOCKING DEALER OR THE CDS-JOHN BLUE TECHNICAL STAFF AT 1-800-253-2583.

Important Message Owners / Operators of Pumps Equipped with Lever Actuated Throw Out Clutches

When using a pump operated by a lever actuated throw out clutch, the rope must be routed by use of eyelet pulleys such that the rope can not become entangled with or come in contact with any moving parts of the tractor or the applicator such as PTO shafts, tractor tires, ground drive units, etc. If eyelet pulleys are not found packed in with the pump, please contact your selling agent or CDS-John Blue Company (1-800-253-2583) immediately before any operations are undertaken.

Verification must be made prior to any operation that the rope is clear of any moving parts while not only driving straight but when making turns either right or left. Verification must be made prior to any operation that the properly routed rope contains no loops, which might become entangled with any part of the equipment or operator.

At no time should the rope be attached to any clothing worn by or to any body parts of the operator such as hands, arms, legs, etc.

We fully understand these are normal precautions owners / operators should take prior to and while operating equipment. However, we wish to remind you that failure to comply with all safety regulations regarding instructing operators in the use of moving equipment and actual operation of the equipment may lead to serious injury and possible death.

To The Owner

This manual has been prepared and illustrated to assist you in the maintenance of your CDS-JOHN BLUE PUMP. Enter your serial number and the date of the purchase in the space provided below for future reference in service information or for ordering parts. Because our engineering department is constantly improving products, we reserve the right to make design and specification changes without notice.

Model Number: _____ Serial Number: _____ Purchase Date: _____

TABLE OF CONTENTS

SAFETY PRECAUTIONS	2
WARNING	2
NOTE TO THE OWNER.....	2
TABLE OF CONTENTS	3
PUMP SPECIFICATIONS	3
PUMP CROSS-SECTION SCHEMATIC	4
INSTALLATION.....	5
PUMP SETTING	6
INITIAL START-UP OF PUMP	8
PUMP CALIBRATION.....	9
MAINTENANCE.....	10
STORAGE	
TROUBLE CHART	
REPAIR	12
REBUILD PUMPING CHAMBER	
REPLACE ROD PACKING	
CRANKSHAFT OIL SEAL REPLACEMENT	
CRANKCASE DISASSEMBLY	
PARTS LIST.....	17
WARRANTY.....	Back Cover

PUMP SPECIFICATIONS

*DISPLACEMENT:	Max 68.4 Gal. Per Minute Max .152 Gal. Per Revolution
*OPERATING PRESSURE:	Max 120 PSI/Min-10 PSI
*OPERATING SPEED:	Max 450 RPM
*ROTATION:	Clockwise or Counter clockwise
*REQUIRED HP: (theoretical)	6.0
*PLUMBING:	2" FPT (female pipe thread) Inlet 1-1/2" FPT Outlet
*DRIVE:	No. 50 Roller Chain
*PHYSICAL DIMENSIONS:	17"L X 14"W X 9"H
*WEIGHT:	136 lbs.
LUBRICATION	
*CRANKCASE:	SAE 90 Gear Oil 48 oz. Capacity
*ZERKS:	Multipurpose Grease

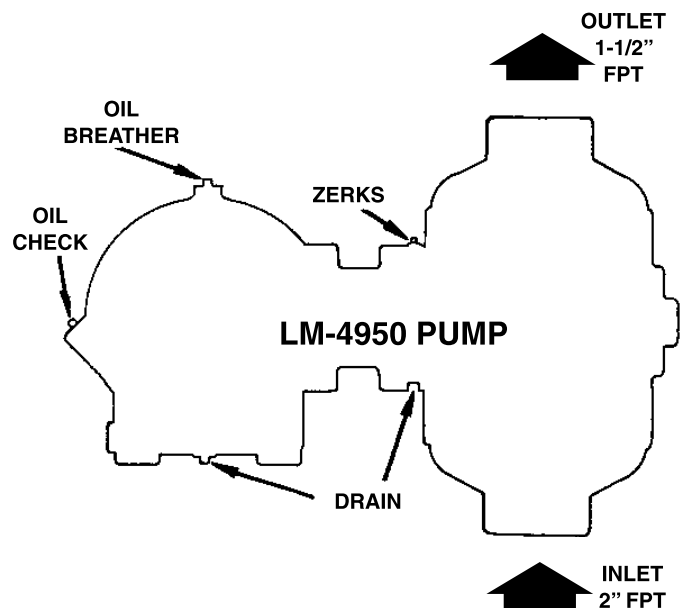

PUMP CROSS-SECTION

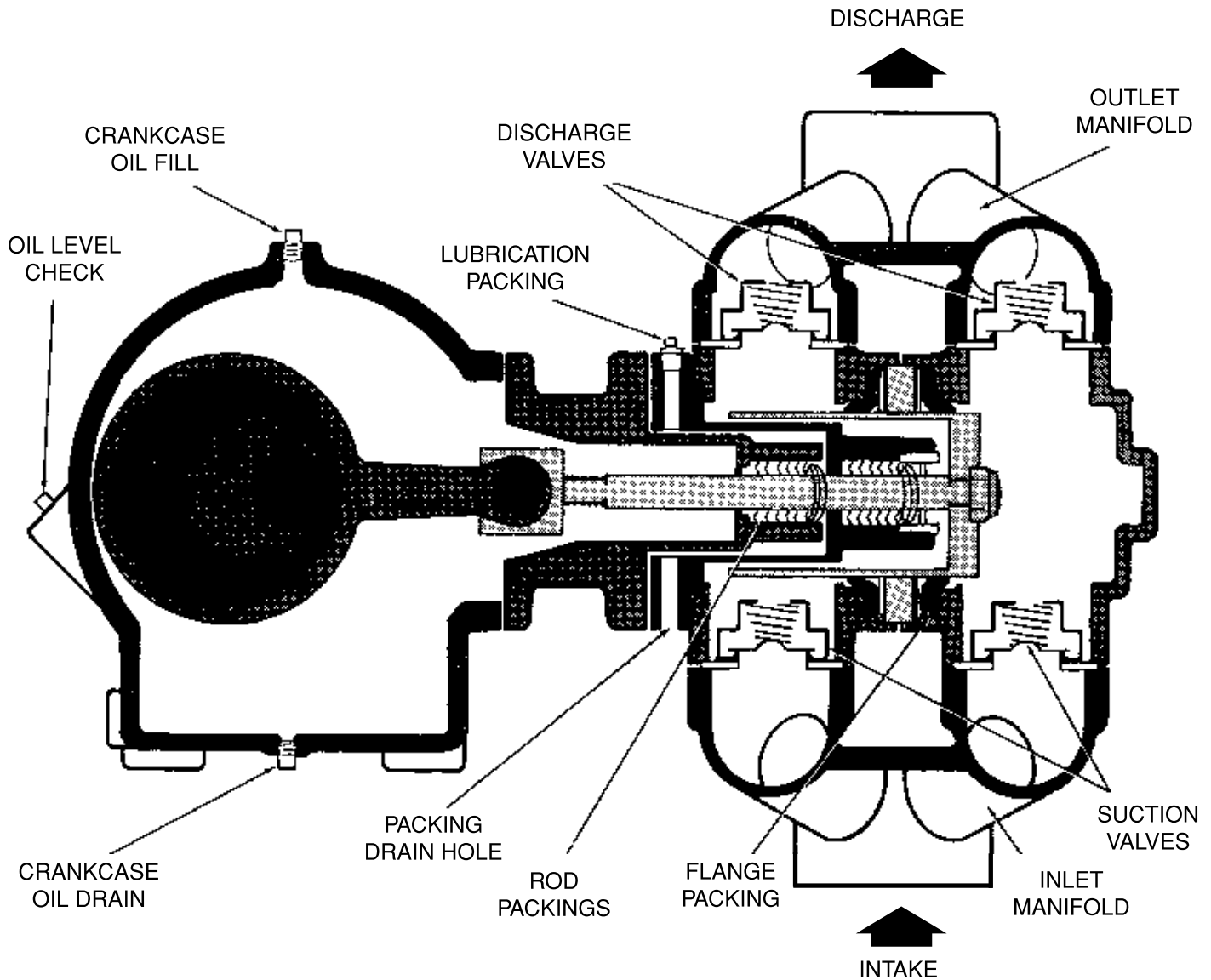

INTRODUCTION

The **LM-4950** series pump is a **double piston**, variable stroke metering pump. It is specifically designed to accurately meter liquid fertilizer solutions. The pump's cast iron construction has stainless steel working parts with components subject to abrasion are hard chrome plated.

The **LM-4950** functions as a positive displacement, chain driven metering device which operates in direct relation to a ground drive. The output rate can be set (covered under PUMP SETTING) before application begins and the GPA (gallons per acre) application will be accurate regardless of the varying speeds of the drive mechanism.

In many pumping systems the flow rate is controlled by the orifice size. The **LM-4950** pump is designed to function accurately within normal pressure parameters of orifice selection. The only function of an orifice with the CDS-John Blue pump system is to spread material properly over an area. The pump controls the metering of the solution.

INSTALLATION

The pump should be mounted on a rigid base in a horizontal position in a location which allows drive chain alignment.

Rubber washers are supplied with your pump. Install these between the pump and mounting surface.

Install the chain idler to run on the slack side of the drive chain.

NOTE: Take precaution to ensure that the rear tractor wheel will clear the pump during sharp turns.

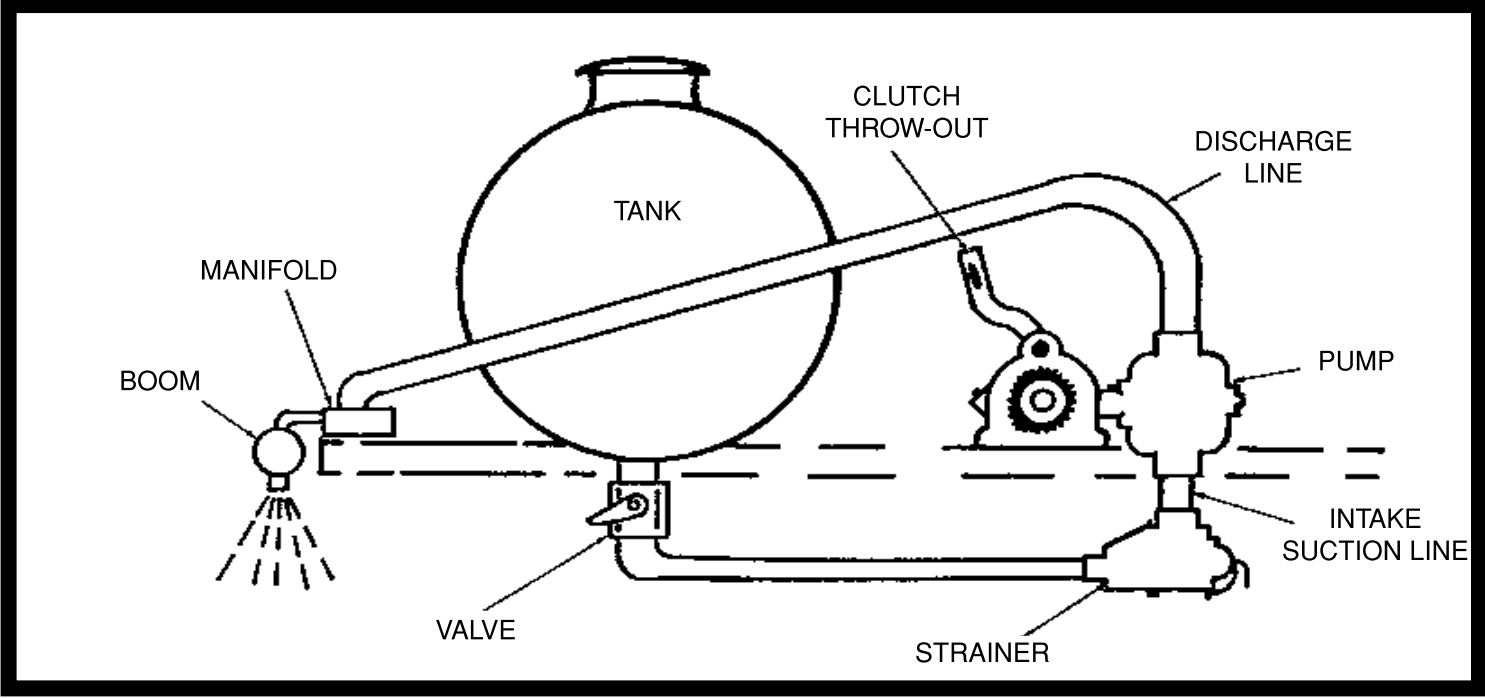
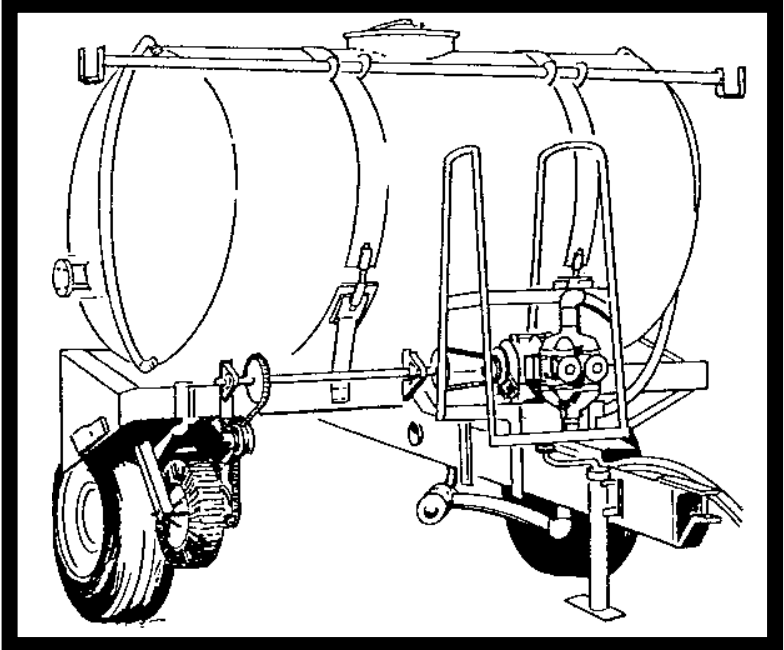
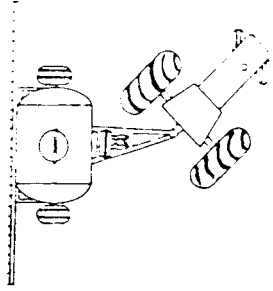

PLUMBING ACCESSIBILITY

- Before mounting the pump on any chassis, give special attention to the plumbing arrangement.
- The strainer is to be installed on the suction side of pump.
- We recommend that the pump be mounted below or level with the tank fluid.
- Install the solution intake line as straight as possible without restrictions from kinks or extremely sharp turns. This will ensure even flow during maximum pump output.
- Install drive chain with proper tightness and alignment.
- Check clutch throw-out yoke clearance to avoid premature wear.

PUMP SETTING

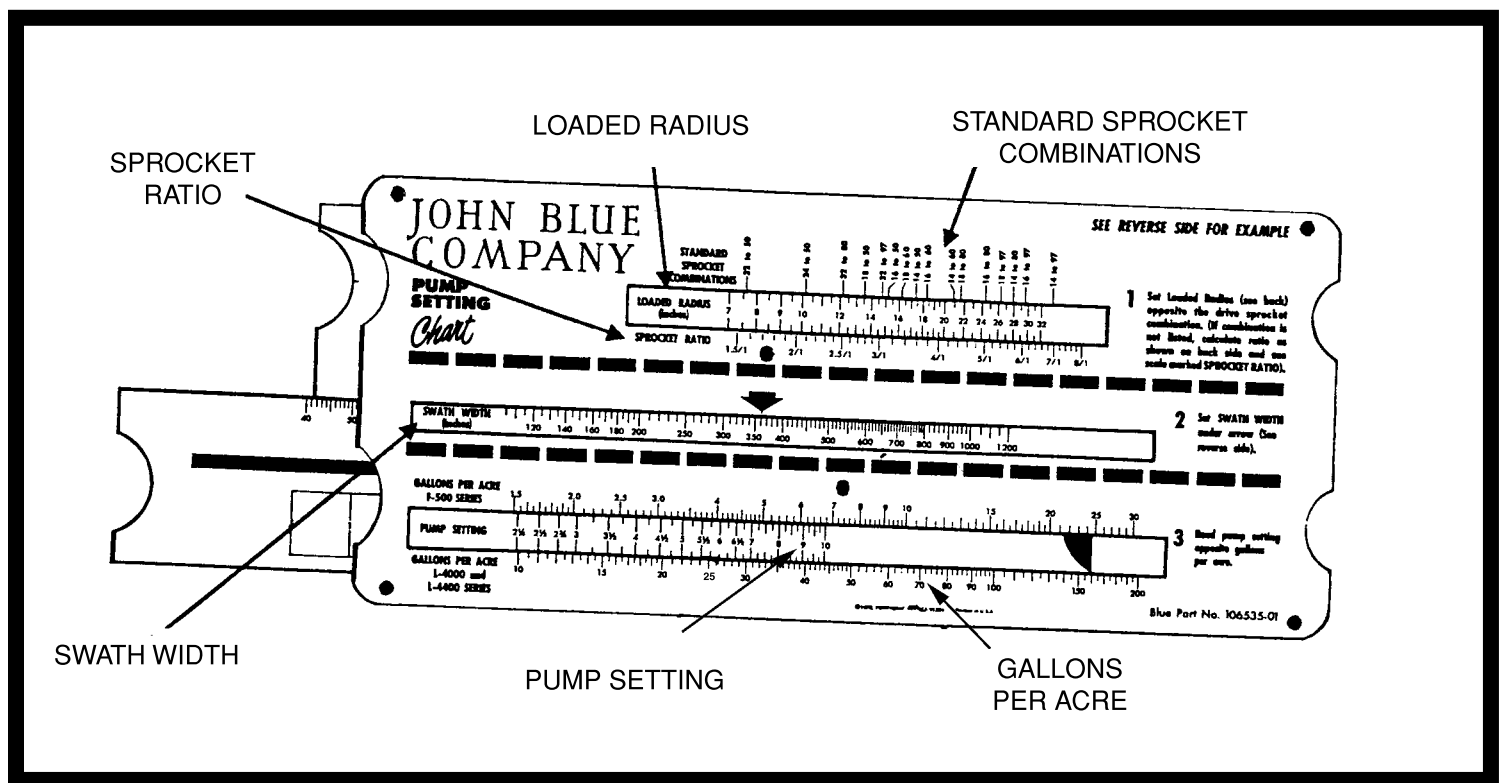

The LM-4950 pump output is determined by the drive sprocket ratio and the stroke length. The John Blue 105913-91 slide chart is used to determine the scale setting required to adjust the stroke length for a desired output.

EXAMPLE: STANDARD** SPROCKET COMBINATIONS

(**Ones used on CDS-John Blue Equipment)

An applicator is equipped with 11L x 15" tires, a 50 tooth drive sprocket, and it is desired to apply 60 gallons per acre on a 480" swath. The following steps will determine correct pump setting:

1. Set Loaded Radius of tire (13.5") under the sprocket combination of 18 to 50 in the top window.
2. Set the swath width (480") under the arrow in the middle window.
3. Read the pump setting of 8.75 above 60 gallons per acre on the bottom scale.

The correct pump setting is 8.75.

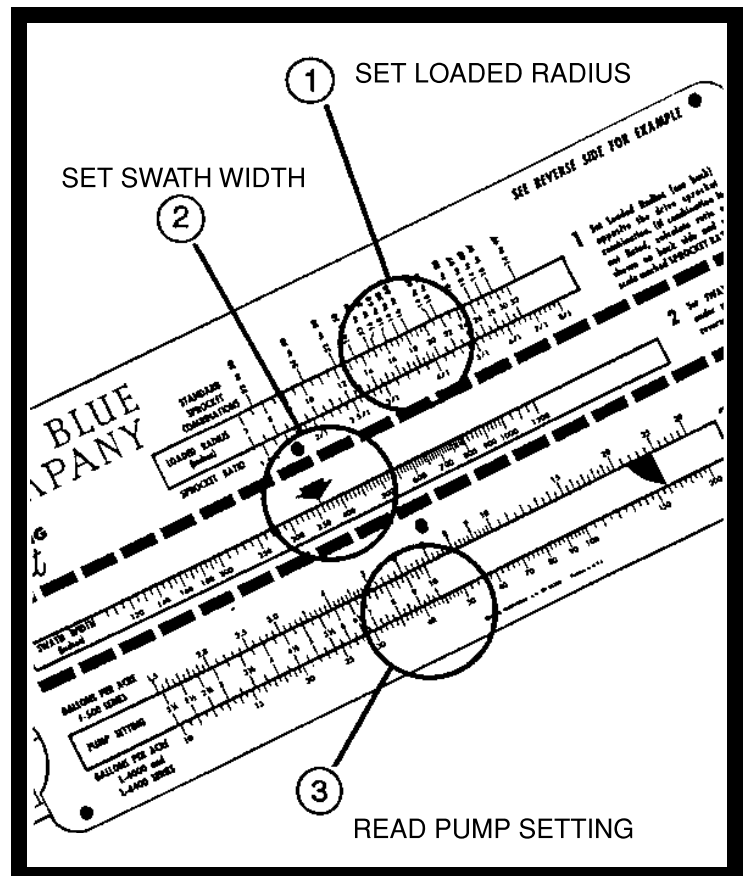

DRIVE RATIO

EXAMPLE: NON-STANDARD SPROCKET COMBINATIONS

If you are using sprocket combinations other than the standards given on the pump chart, use the following formula to determine the drive ratio:

$$\frac{\text{Drive Sprocket}}{\text{Driven Sprocket}} = \text{DRIVE RATIO}$$

$$\frac{50 \text{ tooth (@ drive wheel)}}{32 \text{ tooth (@ driven shaft)}} \times \frac{32 \text{ T (@ drive shaft)}}{18 \text{ T (@ driven pump)}}$$

$$\text{The drive ratio is: } \frac{50}{32} \times \frac{32}{18} = \frac{50}{18} = 2.77$$

The correct sprocket ratio is 2.77.

The sprocket ratio is shown as the third line of figures on the slide chart and can be used on any drive arrangement.

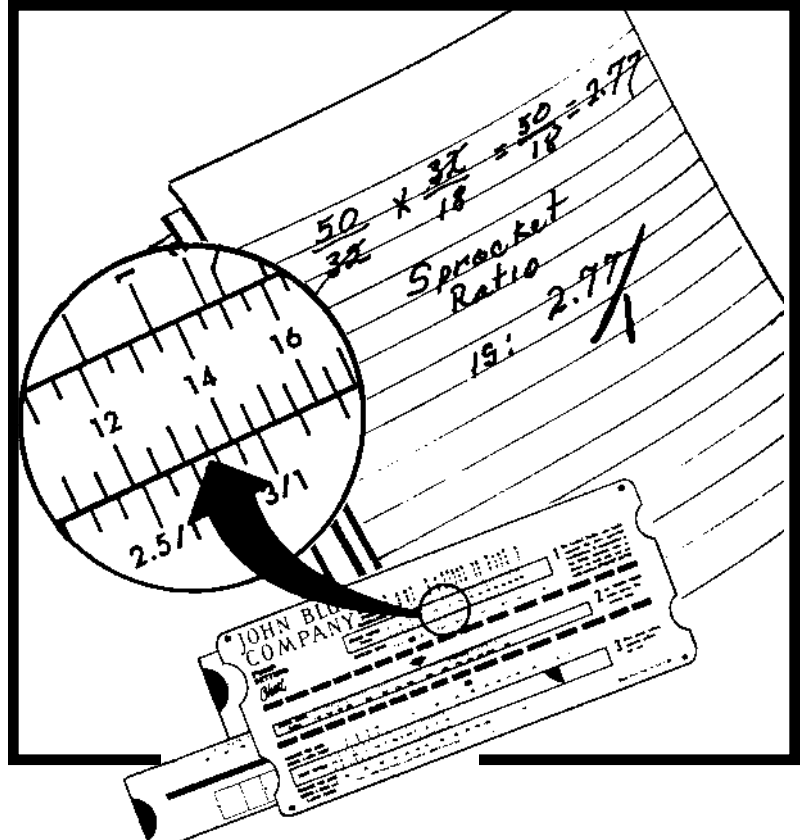

LOADED RADIUS

The measurement for the loaded radius must be from the manufacturer of the tire or be measured under loaded conditions.

GROUND WHEEL DRIVE ARRANGEMENT

Measure the loaded radius from the center of hub to bottom of tire where it rests on the ground.

PRESS WHEEL DRIVE ARRANGEMENT

Measure the loaded radius from the center of the press wheel shaft to the position where the wheel rests against the tire which carries the unit. The press wheel must be engaged for normal operation to give an accurate reading.

The calculation for sprocket ratio is the same for ground drive or press wheel, once the proper measurement is made for the loaded radius.

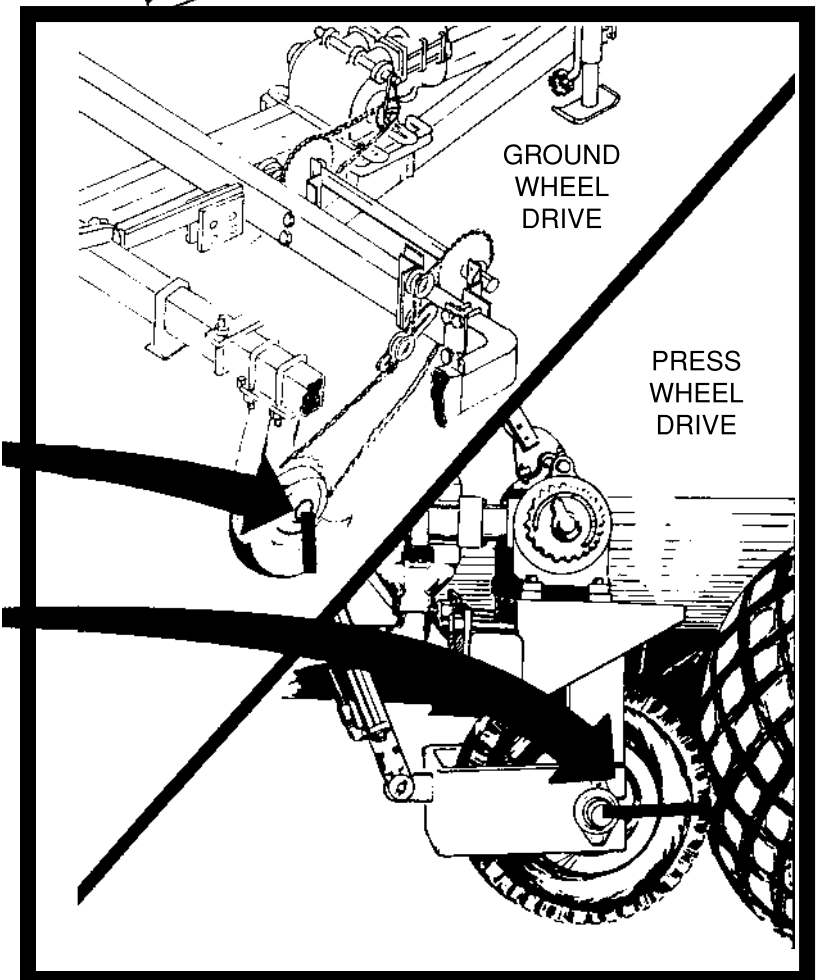

INITIAL START-UP

SWATH WIDTH

To determine the swath width of the applicator, count the number of outlets and multiply times the distance (in inches) between any two outlets, nozzles or shanks.

For example: a Boom with 11 nozzles spaced at 60 inches would have a swath width of 660" NOT 50 feet.

This assumes that all outlets are equally spaced. If outlets are not evenly spaced, figure the entire length of the boom or toolbar from end nozzle to end nozzle and allow for coverage beyond ends.

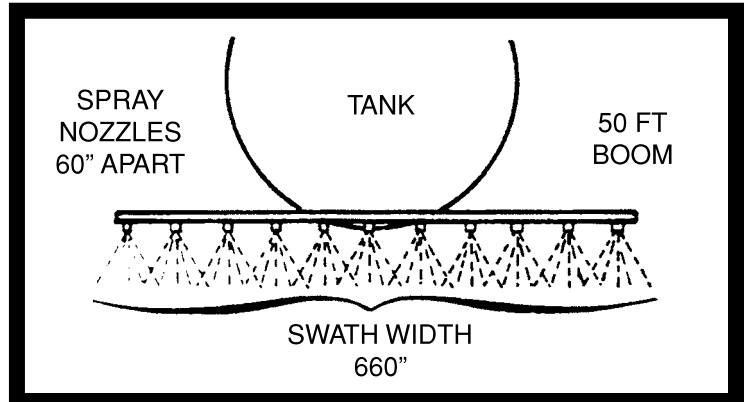

PUMP SETTING

Read the desired pump setting from the bottom scale on the pump setting chart.

Loosen the scale setting nut and rotate the dial disc until the pointer is over the desired setting. The L-3092-AS pump setting wrench will facilitate rotation of the dial disc if it tends to be hard to turn.

Tighten the scale setting nut, being careful not to over-torque it.

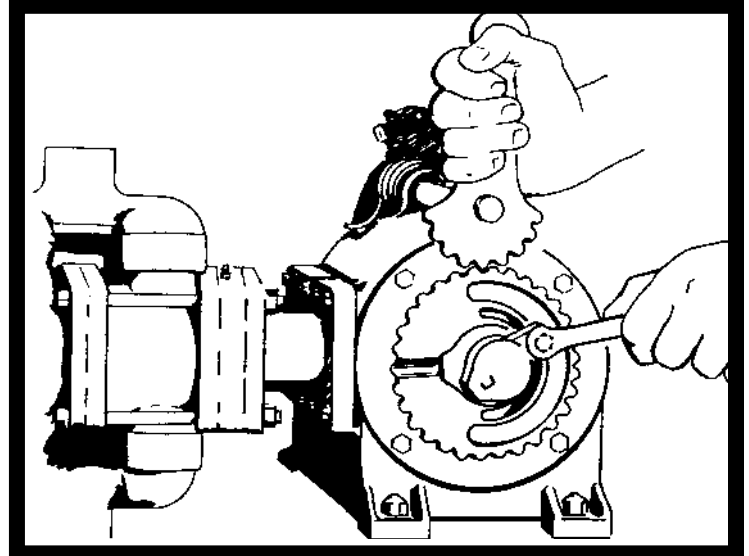

INITIAL START-UP OF PUMP

Fill tank one-half full of water to test for leaks in the plumbing system and output of the pump.

Fully open the valve at the tank allowing water to fill the suction line and check for leaks. Your pump is factory set at 10. You will not need to reset it for this test run. If the system includes a flow divider, open this and relieve back pressure or remove hose.

Before installing nozzles or orifices, prime the pump and purge the system of air and foreign material by slowly pulling the applicator 100 to 200 yards.

Turn off the valve at the tank, open strainer and remove screens. Visually check and remove foreign materials. Install proper orifices and set pump.

Pull the machine over known acreage and verify accuracy of application by subtracting amount of water left in tank from amount at the beginning of the test.

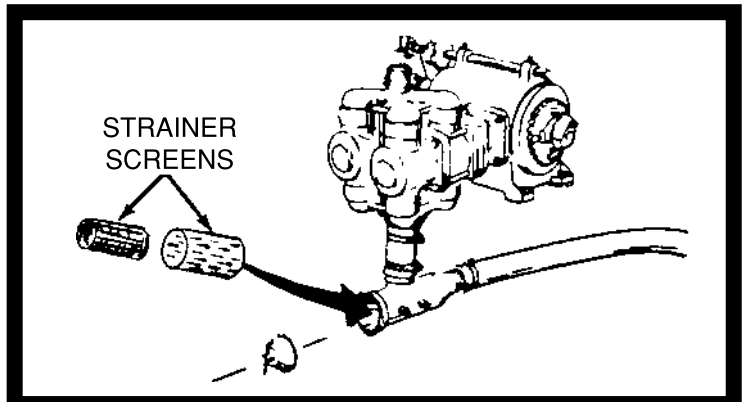
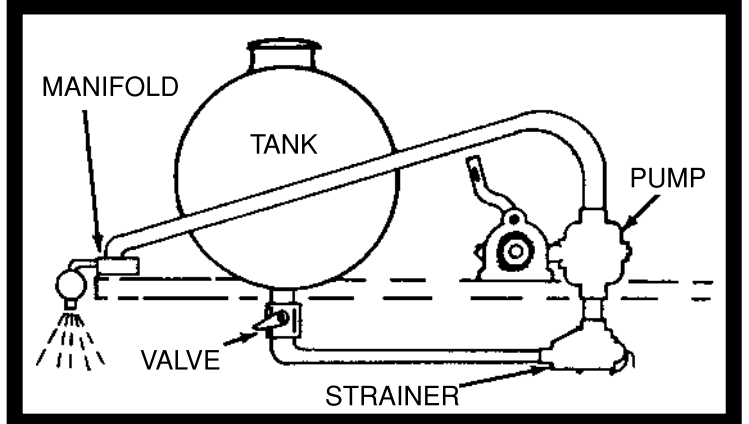

PUMP CALIBRATION

If the pump setting scale becomes lost or loose use the following procedure to calibrate the pump output with dial readings.

Remove the outboard cylinder and replace the bolts and washers to hold the inboard cylinder and stuffing boxes in place.

With the scale attached to the dial disc, loosen the pointer setting nut and move the pointer to 5. Tighten the pointer nut.

Rotate the crankshaft until the exposed piston is as far in the inboard cylinder toward crankcase as it will go.

With a tri-square or straight edge and rule, measure the distance from the end of the piston to the cylinder flange.

Rotate the crankshaft until the piston is as far out as it will go and measure again to the same place.

The difference in the measurements is the stroke length, which @ 5 should be $15/16$ ". If the distance is less than $15/16$ ", reset the pointer at a higher setting.

If the difference is greater than $15/16$ ", reset the pointer less than 5.

Repeat this procedure as many times as necessary to obtain the $15/16$ " stroke length.

When the $15/16$ " stroke is obtained, tighten the pointer nut, locking it in position.

Loosen the three scale screws and move the setting scale until the 5 is directly under the pointer. Secure the scale in position.

This completes the calibration. Replace the outboard cylinder.

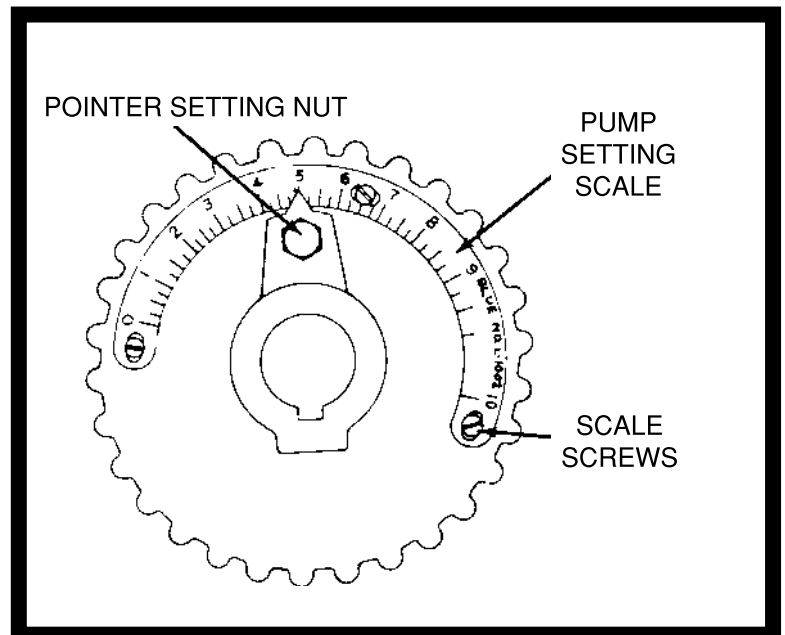
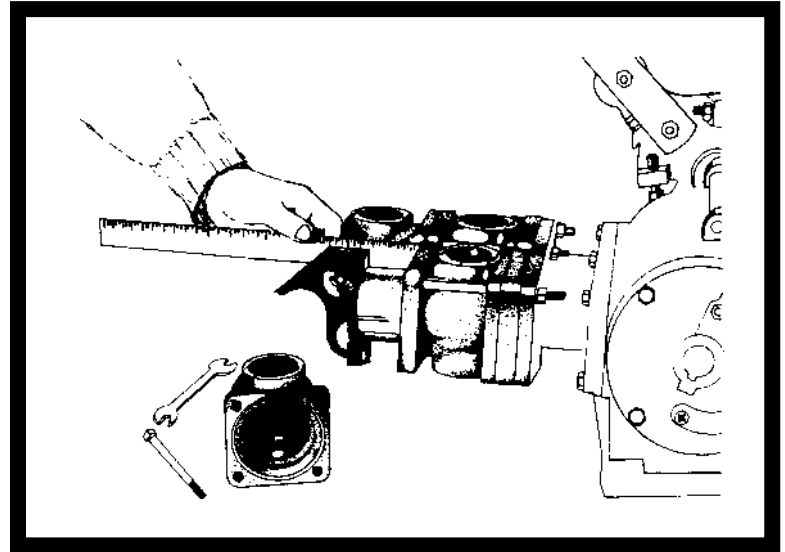

PUMP ACCURACY

Check pump displacement by measuring output of water for a known number of strikes.

Disconnect suction hose and insert in a container of water. Thoroughly flush and prime pump.

Set pump at 8-1/4 and turn exactly 10 revolutions. The amount of water discharge should be **5 quarts**.

This test should be used only to verify pump output, not as a calibration method.

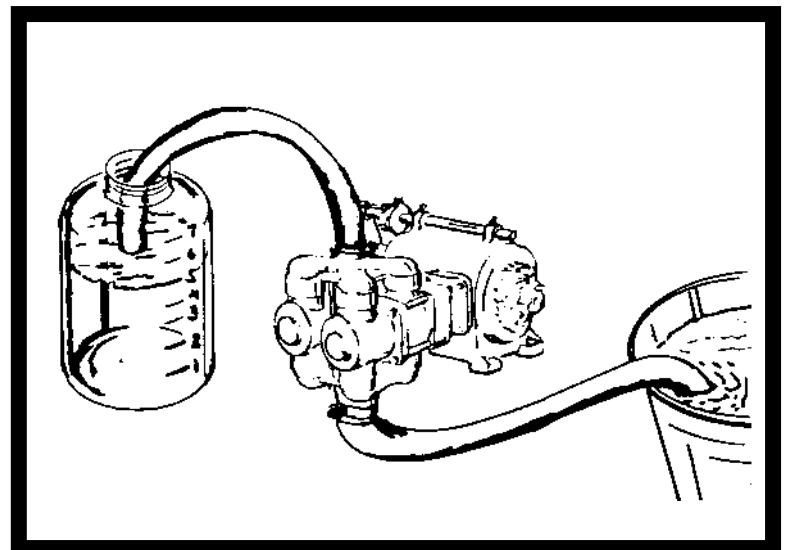

MAINTENANCE

LUBRICATION

Check oil daily and fill crankcase with a good grade 90 weight EP gear oil. Oil level must be visible at oil check on back of crankcase for proper operation of pump.

Lubricate zerks on roller chain sprocket, clutch and throw-out cam daily.

Lubricate Daily, the automatically tensioned stuffing boxes between the crankcase and discharge manifold. Fill zerks until packing lubricant seeps out of drain hole in the bottom of the stuffing box.

Visually inspect sprocket, drive chain, clutch and throw-out yoke daily. Lubricate drive chain with oil regularly. Chain alignment and throw-out yoke clearance must remain as originally set.

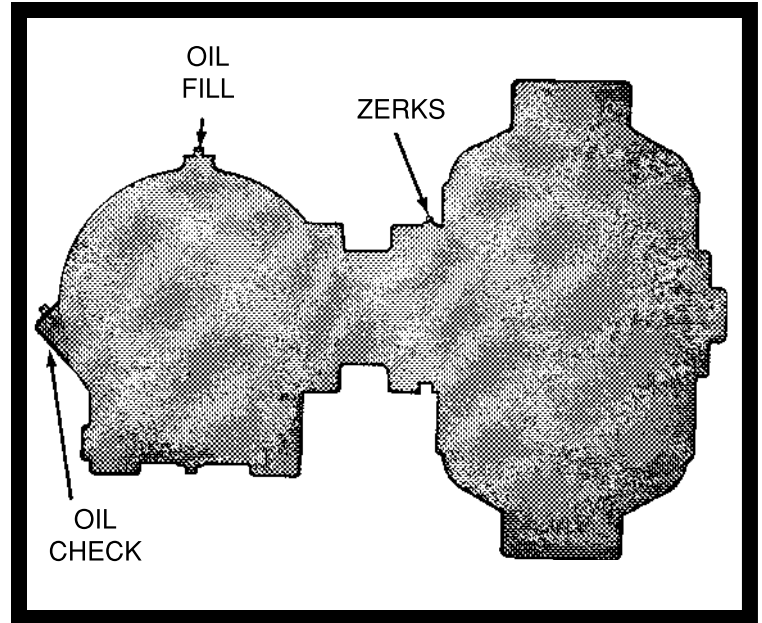

REVERSING CLUTCH THROW-OUT LEVER

Disengage throw-out lever spring from the pawl. Remove capscrew from handwheel assembly and slide off handwheel and its tension spring.

Relieve tension from the torsion spring and remove clutch throw-out assembly from the throw-out rod.

Remove torsion spring (**114165-01**) and replace with **114164-01** opposite wound spring. (Not supplied with pump, may be ordered).

Reverse direction of the throw-out lever and attach the throw-out lever spring on the opposite end of pawl.

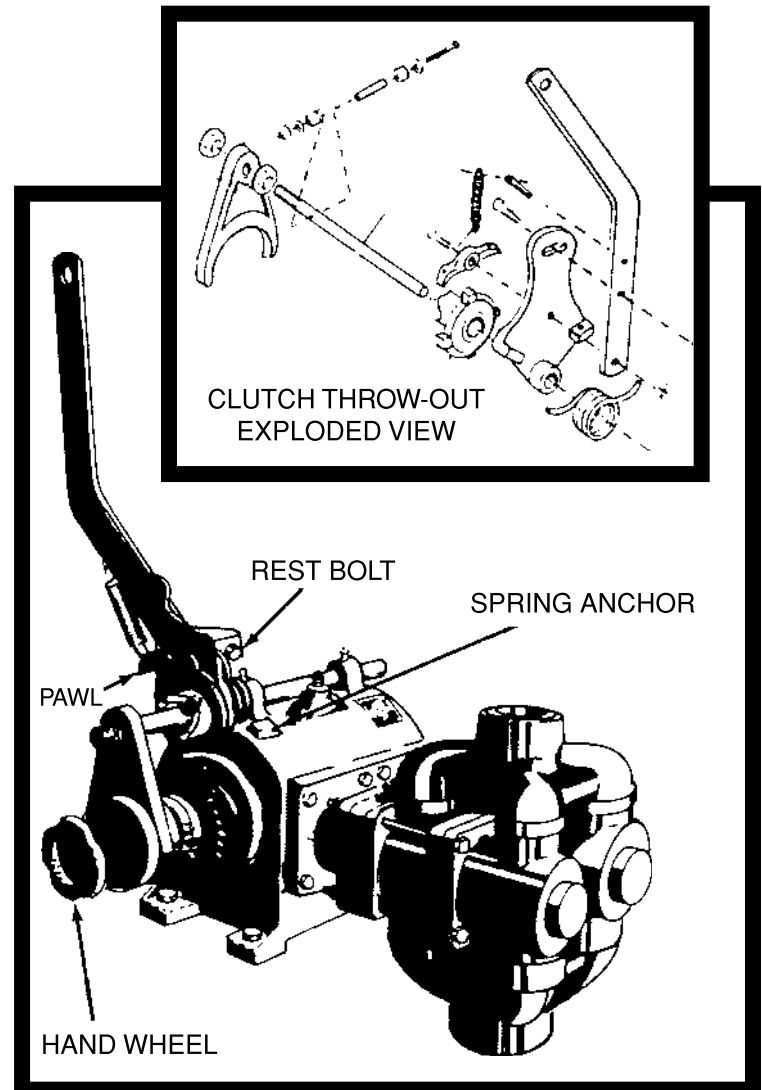

KEEP AIR OUT

KEEP FROM FREEZING

RECOMMENDED STORAGE PROCEDURES

KEEP AIR OUT OF PUMP! This is the only way to prevent corrosion. Even for short periods of storage, the entrance of air into pump, will cause RAPID AND SEVERE CORROSION.

OVERNIGHT

SUSPENSION FERTILIZER must be flushed from the pump for ANY storage period.

FOR CLEAR LIQUIDS:

1. Steady or rising temperatures: leave pump and hoses filled with solution. DO NOT DRAIN or admit air into the pump.
2. Cooling weather: (solution likely to salt out), fill pump with water and leave filled. DO NOT admit air.

ONE TO TWO WEEKS

ACCEPTABLE: Flush pump thoroughly with 5 to 10 gallons of a solution that will neutralize the liquid last pumped (refer to that manufacturer's instructions). Fill with clean water and DO NOT DRAIN. Keep pump sealed to exclude air. If freezing temperatures are remotely possible, the winter storage procedure (see below) must be used to avoid damage to the pump castings.

PREFERRED: Flush pump as detailed above. IMMEDIATELY fill all passages in pump with straight RV-antifreeze which contains a rust inhibitor. Place PVC plugs in the suction and discharge fittings to keep pump full and exclude air.

WINTER STORAGE

1. Flush pump as detailed above.
2. With pump set on 10, draw in straight RV-antifreeze until the discharge is clean. If system utilizes a flow divider (FD), pump the RV-antifreeze through the FD manifold until it is seen in the discharge lines. Fill pump and plug suction and discharge fittings of pump to retain RV-antifreeze.

TROUBLE CHART

TROUBLE	PROBABLE CAUSE	CORRECTION
1. Pump hard or impossible to prime	a. Valves fouled or in wrong place	Page 12
	b. Air leak in suction line	Page 5
	c. Pump set too low	Page 8
	d. Packings worn out	Page 13
2. Low metering	e. See a., b., c., above	
	f. Broken valve spring	Page 12
3. Over meters	g. Broken discharge valve spring	Page 12
	h. Trash under valves	Page 12
	i. Improper setting	Page 8
4. Leaks through when stopped	j. See g. and h.	
5. Fertilizer solution leaking under stuffing box	k. Rod packings worn out	Page 13
6. Pump using excessive oil	l. Oil seals or O'Ring worn and leaking	Page 12/14
7. Pump operates noisily	m. Crankcase components worn excessively	Page 14

PUMPING CHAMBER REBUILD

Pumping chamber rebuilding is an economical way to ensure that your pump will give optimum service for several years. This type of rebuilding is simple, and can be done by almost all end users. The **LM-4950** pump repair kit includes all seals and gaskets needed for normal rebuilding and can be ordered by stock number **111947**.

CLEAN AND CHECK VALVES

Remove suction and discharge (top) manifolds and notice that all valve spring cages are turned upward and valves with stronger spring belong in the discharge manifold.

Do not remove valves. Many valves are damaged beyond use be needlessly removing them from the manifold.

Push each valve disc off its seat, check for trash and ensure that the spring reseats each valve disc evenly. Inspect for damage such as cracks or chips in the seating rim of the valve.

Check the condition of the O'rings seals, replace if broken or cracked. An air leak will cause the pump to meter low.

Once all valves are checked and O'rings are in position, replace manifolds using care to tighten bolts evenly.

REPLACE PISTON SEAL FLANGE PACKINGS

With both intake and discharge manifolds removed, remove outboard cylinder and remove flange packing from packing recess.

Notice the position of the 2 flange seals and the gaskets as you remove them.

Remove the plastic washer and then remove the other flange packings from the inboard cylinder recess. The flange seal must be pliable and without cracks or nicks to perform properly. Inspect the seals and replace if necessary.

Clean cavities in both the inboard and outboard cylinders.

Inspect piston for scratches, indentions, or severe abrasion. Discoloration of the plunger can be deceiving. The best way to check is by feel. Indentions around piston may be more detrimental than one running horizontally. Indentions may indicate a need for replacement.

Reinstall the inboard flange seal using one or more gaskets over lip to make packing seat firmly. These flange seals should have clearance between heel of flange and piston. However, make sure lips seal and fit snugly around piston completely.

Place the plastic washer on the piston and replace outer flange packing as above.

Use the same quantity of gaskets as were removed.

Reassemble outboard cylinder ensuring that the inboard and outboard cylinder do not touch without considerable compression. If these parts fit together too easily, disassemble and add more gaskets.

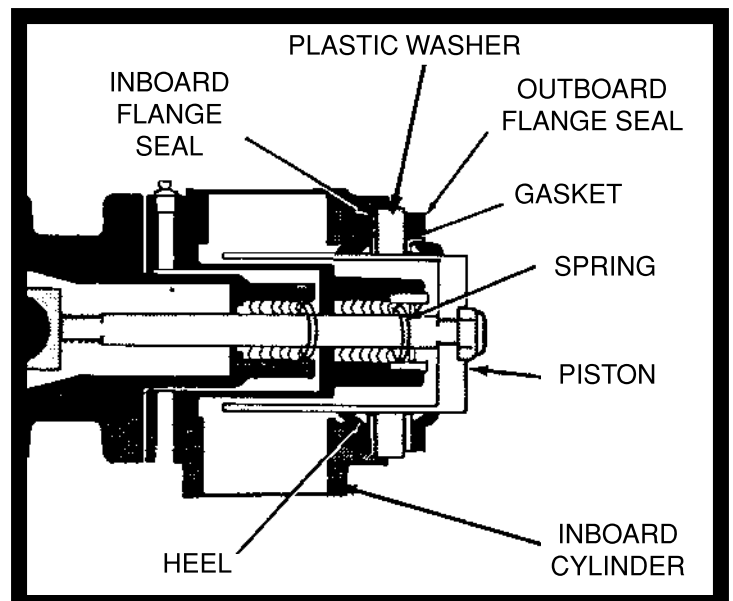
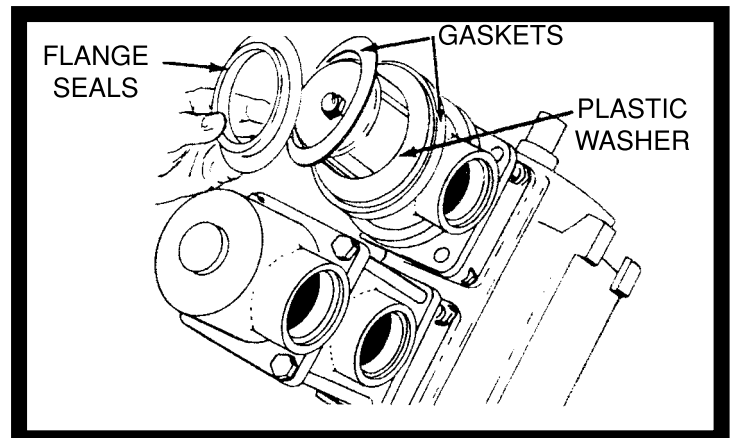
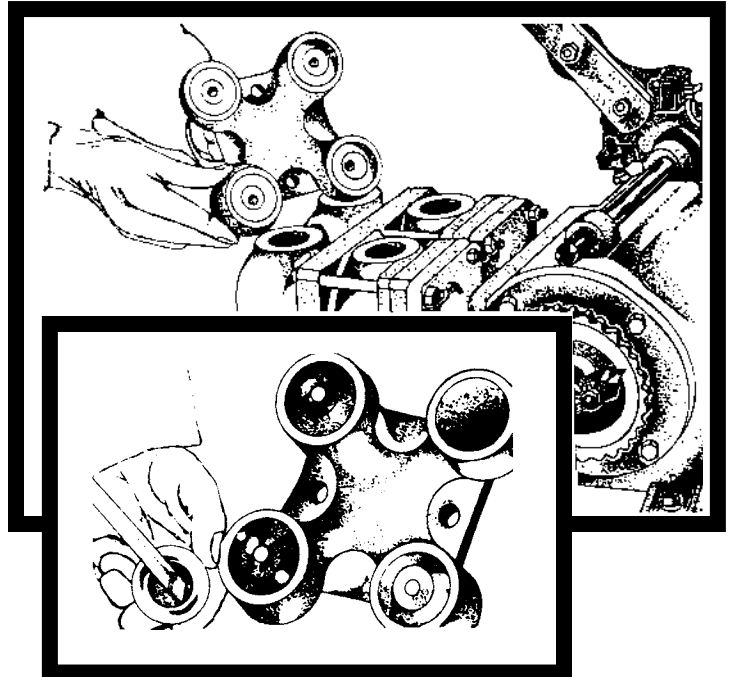

REPLACE ROD PACKINGS

The rod packings are 2 sets of self-tightening “vee” rings which seal around the piston rod to prevent contamination of the crankcase. Virtually any leakage of the fertilizer material being pumped, through the drain under stuffing box is an indication that these rod packings need replacement. However, it is not uncommon for oil to drip from this drain.

REPLACE PISTON ROD VEE PACKING

With both manifolds removed, remove the outboard and inboard cylinder. Then remove the stainless steel hex nut from piston.

Remove piston by rotating counter-clockwise. If piston is hard to turn, use a belt wrench or pipe wrench over cloth to prevent damage to the piston. Grip the piston as near the end as possible.

Remove the stuffing box and crosshead guide which house the rod and packing set.

Remove the snap-ring from the end of the stuffing box, allowing washer and spring to slip out.

Remove first packing set with a hook or other metal prying instrument.

There is no snap-ring on the second packing set. Remove this in the same manner.

Inspect the rod and bushing at the connecting rod. If bushing replacement is needed, refer to page 16 of this manual for instructions.

Carefully reinstall the crosshead guide and bolt to crankcase.

Lubricate rod and carefully install the first “vee” packing set. (Check drawing for proper orientation of rod “vee” packings.) Install washer and spring.

Install second packing set, washer, spring and snap ring retainer in stuffing box. (Check drawing for proper orientation.)

Lubricate piston rod and stuffing box, then slide stuffing box carefully back over rod.

Reassemble piston, inboard and outboard cylinders and manifolds in reverse order. Install bolts.

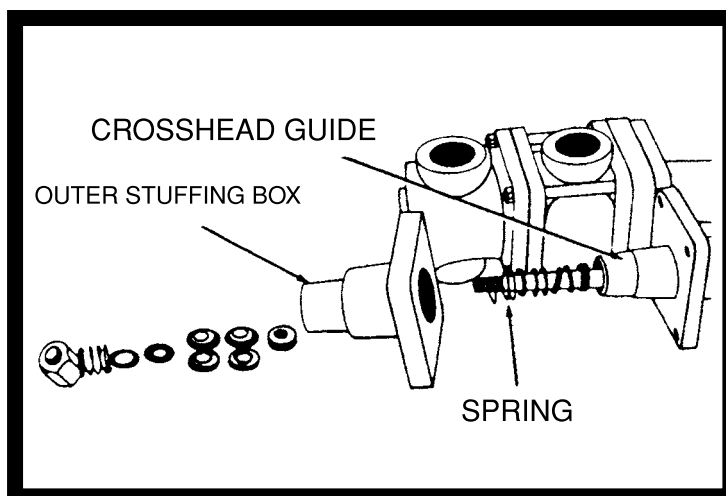
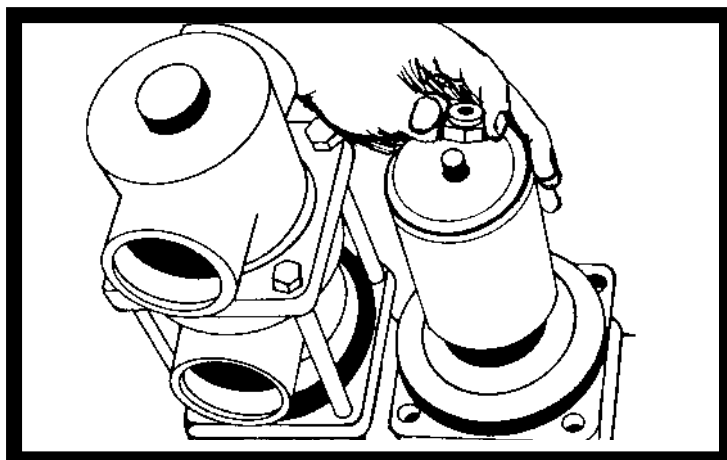
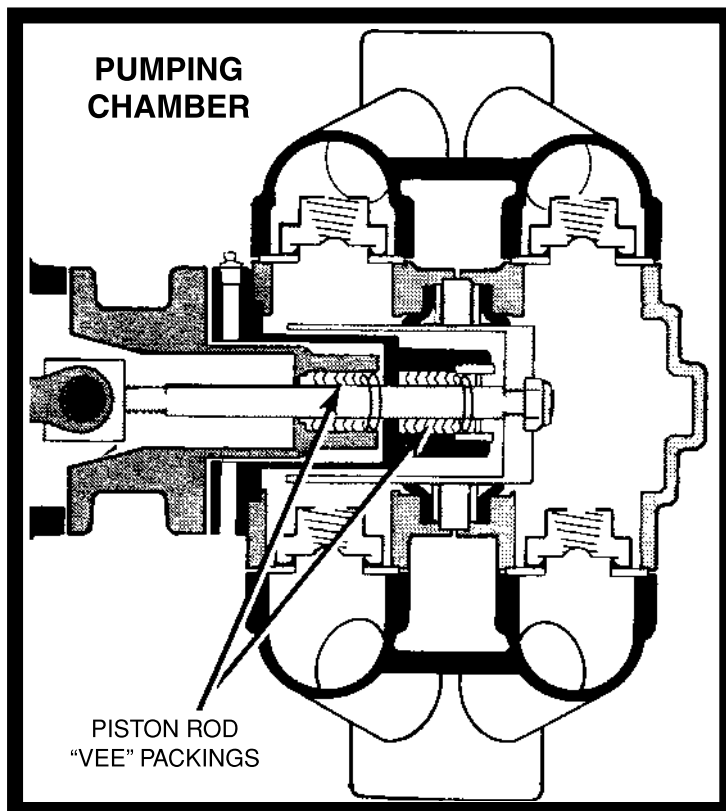

CRANKSHAFT OIL SEAL REPLACEMENT

Lubricate stuffing box until lubricant seeps out of drain hole in the bottom.

REPLACING OIL SEALS AND CRANKSHAFT O'RING

From the setting end of the crankcase, remove stroke setting arm and stroke setting flange.

Remove cover plate and replace grease seal with new seal from 111947 seal kit.

Inspect gasket for breaks and tears on coverplate and replace if necessary.

Remove stroke setting sleeve and inspect for obvious wear or "nicks" which might cause seal failure.

Lubricate O'Ring and place it back on the crankshaft.

Replace stroke setting sleeve, making sure that the eccentric pin slips into the groove of sleeve.

Reassemble coverplate, stroke setting flange and stroke setting arm in reverse order of disassembly.

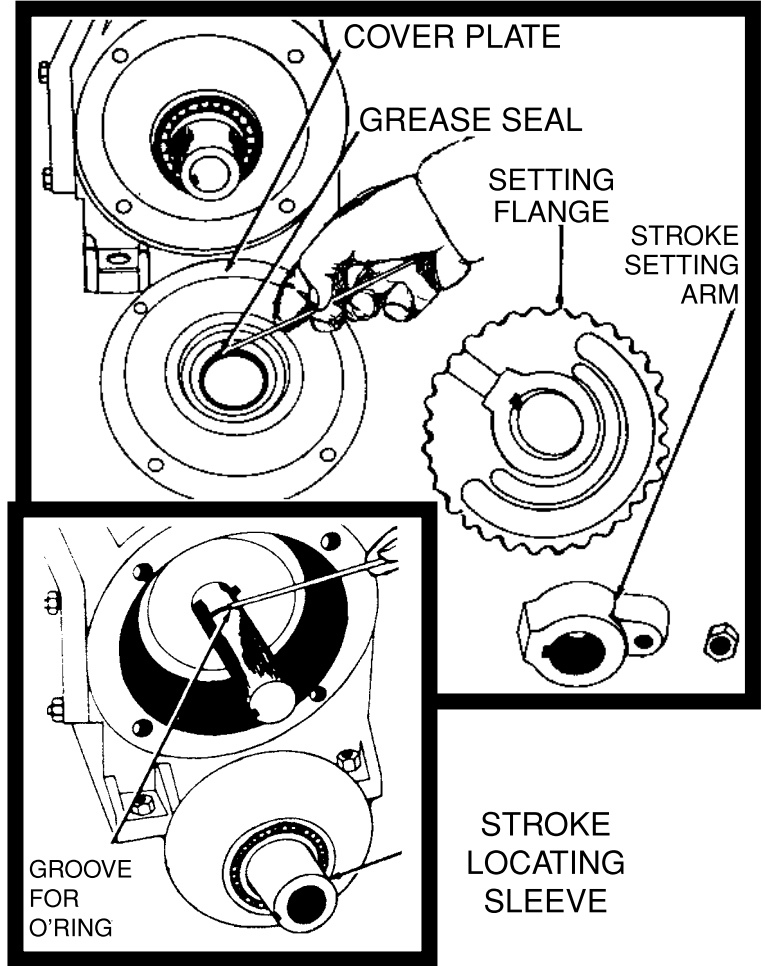

REPLACE SEAL AT THROW-OUT END OF CRANKCASE

Disengage throw-out lever spring from the pawl.

Remove capscrew from handwheel assembly and slide the handwheel and its tension spring off the crankshaft.

Relieve tension from the torsion spring and remove clutch throw-out assembly from the throw-out rod.

Remove rollpin from collar, and remove collar and sprocket from crankshaft.

Remove bearing housing and seal from crankshaft and replace seal.

Inspect crankshaft for obvious wear or nicks which might cause seal failure.

Inspect bearing housing gasket and replace if it shows wear, breaks or tears.

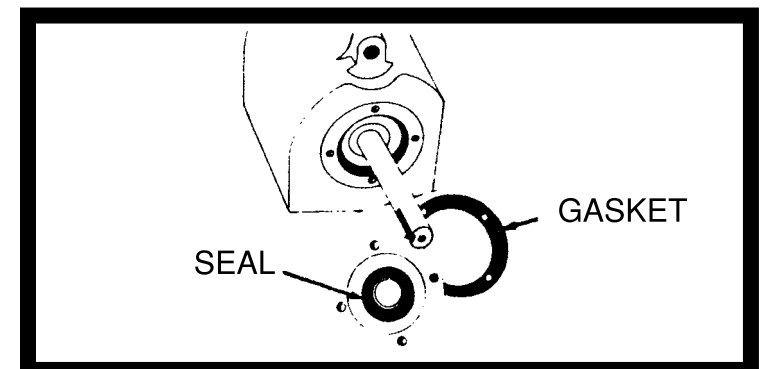
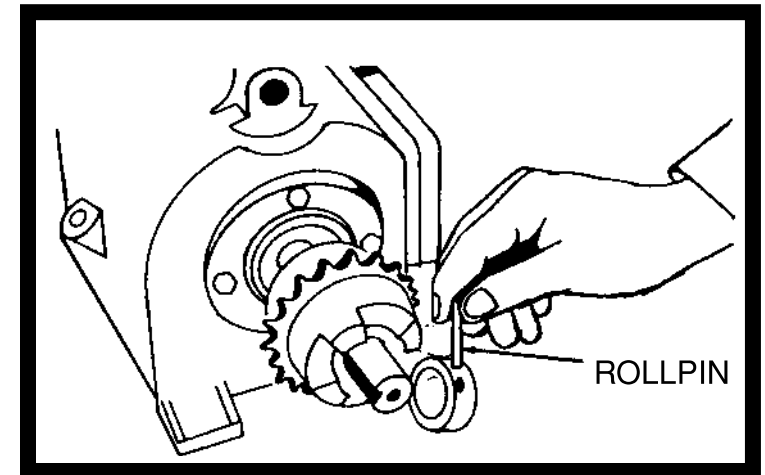

CRANKCASE DISASSEMBLY

Reassemble in reverse order.

Major pump repair requires some in-depth knowledge on working tolerances for internal parts. We recommend that you contact your nearest John Blue Sales and Service dealer for the best results in major pump repair.

With pumps which have been in service for several years, a history of use is helpful. If a pump has been in use by a farmer for 5 to 10 years without any repair, a slight wear on internal parts will probably give another 5 years of good service before wear would justify other parts replacement.

However, if a pump is being used by a dealer using suspension fertilizers, one more year may result in additional parts failing and replacement of drive line components would be justified.

CRANKCASE DISASSEMBLY

Remove pumping chamber components in the following order;

1. Upper and lower Manifolds
2. Outboard cylinder
3. Cylinder packing
4. Inboard cylinder
5. Piston assembly
6. Rod packing
7. Outboard stuffing box
8. Crosshead guide
9. Crosshead pin, bushing and rod

Examine sediment in the crankcase. There will always be a small amount of metal wear and "grit" in the oil.

Check for metal and/or fertilizer discoloration to the oil.

If oil shows fertilizer present, the crankcase should be disassembled and each component examined for rust pitting or deterioration.

Holding the crankcase firmly, take hold of the connecting rod and push and pull. If you feel obvious end play, disassemble all components and examine for wear.

When examining components, give more attention to ones showing "galling" than to ones which are undersize, yet smooth.

Remove stroke setting arm and flange.

Remove clutch and throw-out assembly in the following order: 3/8" bolts, handwheel and spring, clutch throw-out assembly, including rod.

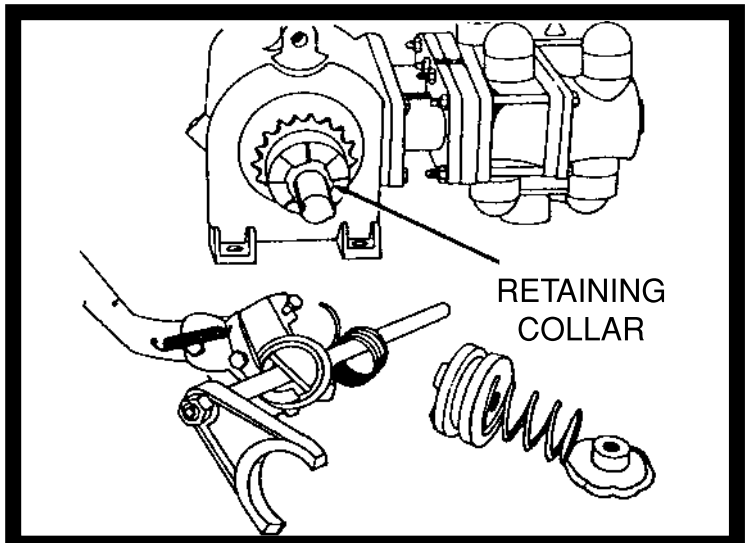
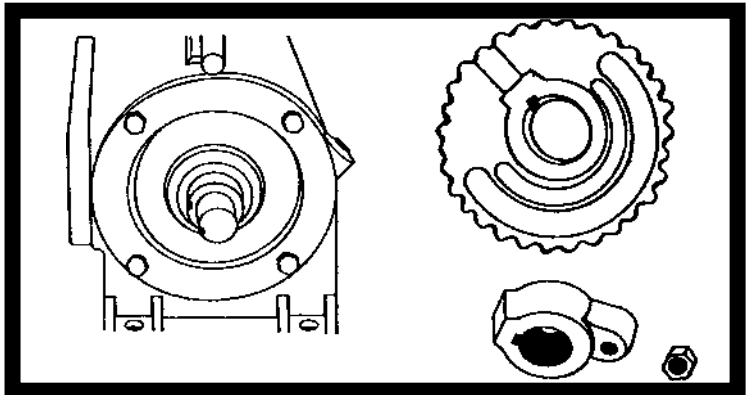
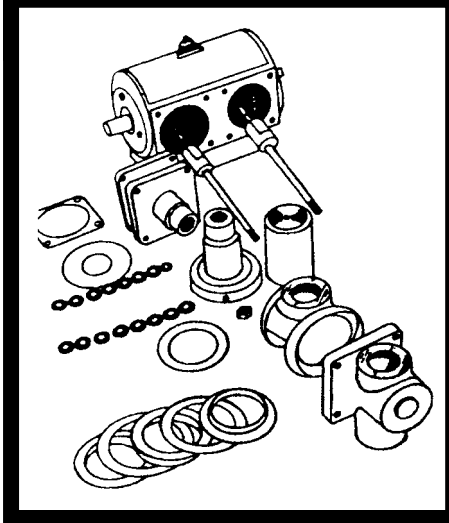
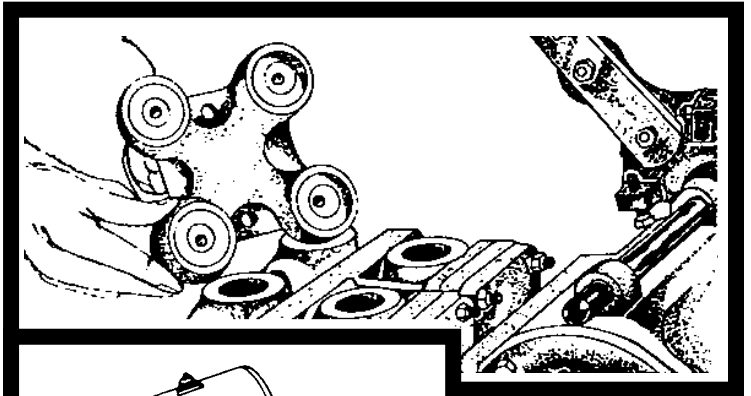

CRANKSHAFT DISASSEMBLY

Supporting the piston rod with a wood block, locate cross-head pin which connects piston rod and connecting rod and carefully drive pin out with a hammer and punch.

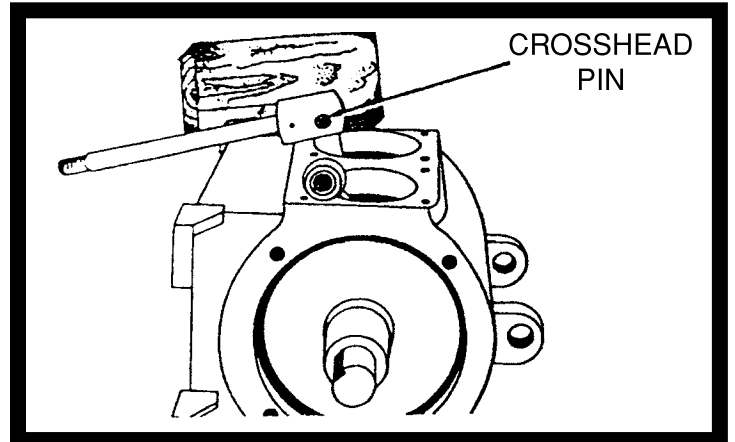

Unbolt end plate from crankcase, slide stroke locating sleeve out and pull large eccentric out of connecting rod and off small eccentric.

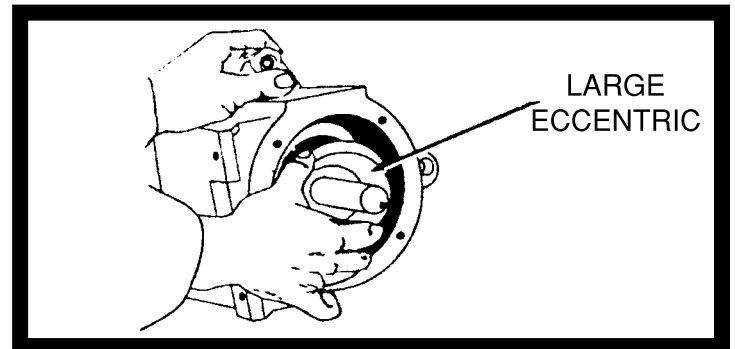

Remove connecting rod and pull crankshaft out.

Examine all components, giving more attention to ones showing "galling" than to ones which are undersize, yet smooth.

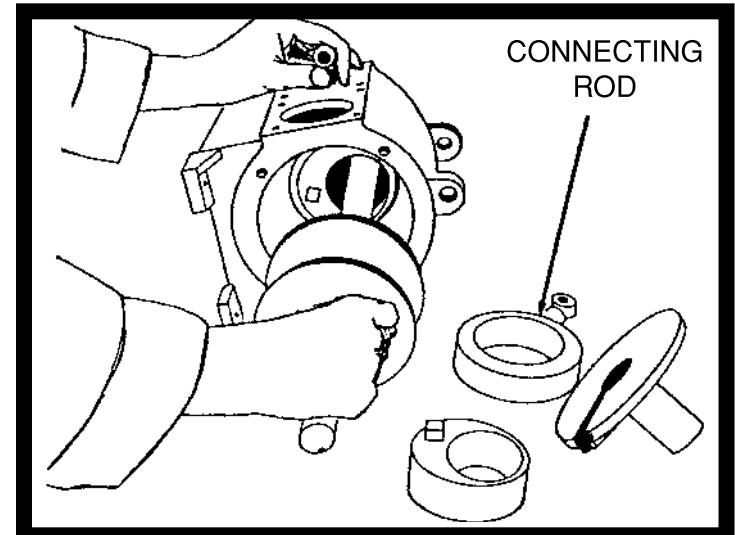

CRANKCASE REASSEMBLY

Reassemble in reverse order. When assembling the stroke locating sleeve, oil the O'ring and twist sleeve onto crankshaft to prevent damage to O'ring.

During reassembly, coat all bolts with permatex before installing on crankcase.

IMPORTANT: In reassembly of stuffing boxes, cylinders and manifolds, leave all bolts loose until assembly is complete. Then turn pump over one cycle with the handwheel. If any binding is noted, adjust stuffing boxes until pump will turn freely, then tighten all bolts securely.

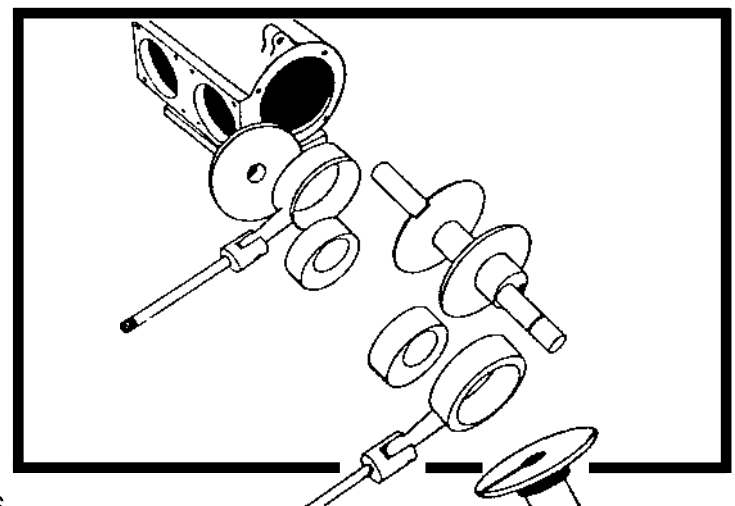

LM-4950 SERIES PUMP PARTS LIST

REF. NO.	PART NO.	ITEM DESCRIPTION	4950 QTY.	4955 QTY.	4959 QTY.	REF. NO.	PART NO.	ITEM DESCRIPTION	4950 QTY.	4955 QTY.	4959 QTY.
1	92037	5/8" JAM NUT	2	0	2	63	105932-91	STROKE SETTING FLANGE	1	1	1
2	113628-01	THROW-OUT YOKE	1	0	1	64	A-368	SETTING SCALE SCREW	3	3	3
3	92014	#10 SQUARE NUT	1	0	0	65	115630-91	STROKE SETTING ARM	1	1	1
4	A-697	WASHER	2	0	0	66	90532	5/16 X 3/8 SET SCREW	3	3	3
5	A-2762	CAM ROLLER	2	0	0	67	H-30	GREASE FITTING	3	3	3
6	A-2763	ROLL PIN	1	0	0	68	93024	3/8 LOCK WASHER	4	4	4
7	90953	2-1/2 RD HD SCREW	1	0	0	69	93011	3/8 FLAT WASHER	4	4	4
8	L-3006	THROW-OUT ROD	1	0	0	70	A-147	LEG MOUNTING PAD	4	4	4
9	90655	3/8 X 1-1/2 HEX BOLT	5	4	4	71	C-431-B	PLUG	3	3	3
10	F-48	THROW-OUT LEVER SPRING	1	0	0	72	105895-01	CROSSHEAD PIN	2	2	2
11	94010	5/32 X 1 COTTER PIN	1	0	0	73	105900-91	PISTON ROD ASSEMBLY	2	2	2
12	90653	3/8 X 1-1/4 HEX BOLT	2	0	1	74	L-3052	CROSSHEAD, GUIDE GASKET	2	2	2
13	L-3064	THROW-OUT LEVER	1	0	0	75	111935-01	CROSSHEAD GUIDE	2	2	2
14	92024	3/8 HEX NUT	14	12	12	76	111943-01	O-RING	2	2	2
***14	T-2010	3/8 NUT-SS	14	12	12	77	L-1109	ROD VEE PACKING SET	4	4	4
15	A-50	HANDWHEEL	1	0	1	78	L-1041	WASHER	6	6	6
16	HA-57	SAFETY CLUTCH SPRING	1	0	0	79	L-1063	PACKING SPRING	4	4	4
16A	108907-01	SAFETY CLUTCH SPRING	0	0	1	80	L-3074	STUFFING BOX GASKET	2	2	2
17	A-260	CLUTCH	1	0	0	81	111937-01	OUTBOARD STUFFING BOX	2	2	2
17A	108905-91	CLUTCH HYDRAULIC	0	0	1	**81	111937-01S	OUTBOARD STUFFING BOX, SS	2	2	2
18	105373-01	CLUTCH COLLAR	2	0	2	82	115134-01	GASKET	2	2	2
19	A-116	OLITE BUSHING	6	2	5	83	L-1042	RETAINING RING	2	2	2
20	H-28	GREASE FITTING	1	0	0	84	L-1031-2	STUFFING BOX INSERT	2	2	2
21	L-4008-A	SPROCKET CARRIER	0	0	1	85	111938-01	INBOARD CYLINDER	2	2	2
21A	108906-01	SPROCKET CARRIER	1	0	1	**85	111938-01S	INBOARD CYLINDER, SS	2	2	2
22	L-4007	18T SPROCKET	3	0	3	86	112816-91	PISTON PLUNGER ASSEMBLY	2	2	2
23	90993	1/4 X 1-1/2 SOCKET HD BOLT	16	16	16	87	L-1047	SELF-LOCKING NUT	2	2	2
24	90637	5/16 X 1 HEX BOLT	1	0	1	88	L-1045-V	FLANGE PLUNGER PACKING	4	4	4
25	L-4249	DRIVE PIN	1	0	0	89	L-1098	PACKING ADJUSTMT. GASKET	4	4	4
26	A-2758-A	PAWL	1	0	0	90	L-1044-A	FLANGE PACKING WASHER	2	2	2
27	A-2757-A	THROW-OUT CAM	1	0	0	91	C-3519	2" THREAD PROTECTOR	1	1	1
28	L-3007	THROW-OUT BRACKET	1	0	0	92	92029	1/2 HEX NUT	2	2	2
29	114165-01	RIGHT-HAND TORSION SPRING	1	0	1	93	111939-01	SUCTION MANIFOLD	1	1	1
30	L-4009	RETAINING COLLAR	1	1	1	**93	111939-01S	SUCTION MANIFOLD, SS	1	1	1
31	110155-01	WASHER, NYLON	1	1	1	94	109112-92	SUCTION VALVE	4	4	4
32	L-1018	OIL SEAL	1	1	1	95	A-2848	VALUE O-RING	8	8	8
33	L-3023	BEARING HOUSING	1	1	1	96	111940-01	OUTBOARD CYLINDER	2	2	2
34	L-3021	BEARING HOUSING GASKET	1	1	1	**96	111940-01S	OUTBOARD CYLINDER, SS	2	2	2
35	L-3019	CRANKSHAFT BEARING	1	1	1	97	91051	3/8 X 8 HEX HEAD BOLT	8	8	8
36	111958-01	NAME PLATE	1	2	2	**97	91072	3/8-16 X 5-1/2 BOLT, SS	8	8	8
37	90634	5/16 X 1/2 BOLT	1	0	0	98	109113-92	DISCHARGE VALVE	4	4	4
38	L-4014	SPRING ANCHOR	1	0	2	99	111936-01	DISCHARGE MANIFOLD	1	1	1
39	90636	5/16 X 3/4 BOLT	1	1	1	**99	111936-01S	DISCHARGE MANIFOLD, SS	1	1	1
40	113634-01	CRANKCASE	1	1	1	100	90711	1/2-13 X 9-1/2 Bolt	2	2	2
41	S-350	VENT PLUG	1	1	1	**100	90710	1/2-13 X 8-1/2 Bolt	2	2	2
42	L-3020	CRANKSHAFT DISC	2	2	2	101	L-3115	1 1/2 THREAD PROTECTOR	1	1	1
43	113645-91	CONNECTION ROD	2	2	2	102	106532-01	18T SPROCKET	0	1	0
44	113629-01	BEARING CRANK PIN	2	2	2	103	90986	3/8 X 5/8 SET SCREW	0	4	0
45	113633-01	LARGE ECCENTRIC	2	2	2	104	110147-01	SPACER	0	1	0
46	L-3017	SMALL ECCENTRIC	1	1	1	105	115031-01	CRANKSHAFT	0	1	0
47	L-3018	STROKE TRANSFER SLEEVE	2	2	2		115122-01	SPACER-ELEC. CLUTCH SHOULDER	0	1	0
48	113588-01	CONNECTING ROD BUSHING	3	3	3		115125-01	1/4" X 1-1/2" DOWEL PIN	0	1	0
49	L-3004	ECCENTRIC PIN	1	1	1	106	114708-91	THROW-OUT ROD ASSEMBLY	0	0	1
50	L-3056	STROKE LOCATING SLEEVE	2	2	2	107	93016	FLAT WASHER	0	0	1
51	L-1020	SETTING ARM KEY	2	0	2	108	105448-01	BACK-UP RING	0	0	1
52	A-261	CLUTCH KEY	1	0	1	109	A-3776	O-RING	0	0	1
53	L-3013	CRANKSHAFT	1	0	1	110	105447-01	BODY	0	0	1
54	A-4333	KEY, WOODRUFF	1	1	1	111	105452-01	BACK-UP RING	0	0	1
55	L-1022	CRANKSHAFT O-RING	1	1	1	112	105461-01	O-RING	0	0	1
56	L-1007-A	BEARING, LOCATING SLEEVE	1	1	1	113	105449-01	PISTON	0	0	1
57	L-1021	OIL SEAL	1	1	1	114	105465-01	BACK-UP RING	0	0	2
58	L-3002	COVER PLATE GASKET	1	1	1	115	A-2849	O-RING	0	0	1
59	L-3001	COVER PLATE	1	1	1	116	105463-01	CYLINDER	0	0	1
60	91017	3/8 SQUARE HEAD BOLT	1	1	1	117	105500-01	BODY O-RING	0	0	1
61	114763-01	PUMP SETTING SCALE	1	1	1	118	93010	5/16 FLAT WASHER	0	0	4
62	A-3097	3/8 SELF-LOCKING NUT	0	1	0	119	93023	5/16 LOCK WASHER	0	0	2
***	115159-91	ELECTRIC CLUTCH KIT	1	1	1	120	92020	5/16 HEX NUT	0	0	2
						121	105501-01	STRAP			2

***Retro-fit Electric Clutch Kit may be adapted to a standard LM-4955 Pump with a serial number after #4800 or with the suffix "-E." **Parts unique to the LM-4950 Stainless Series only.

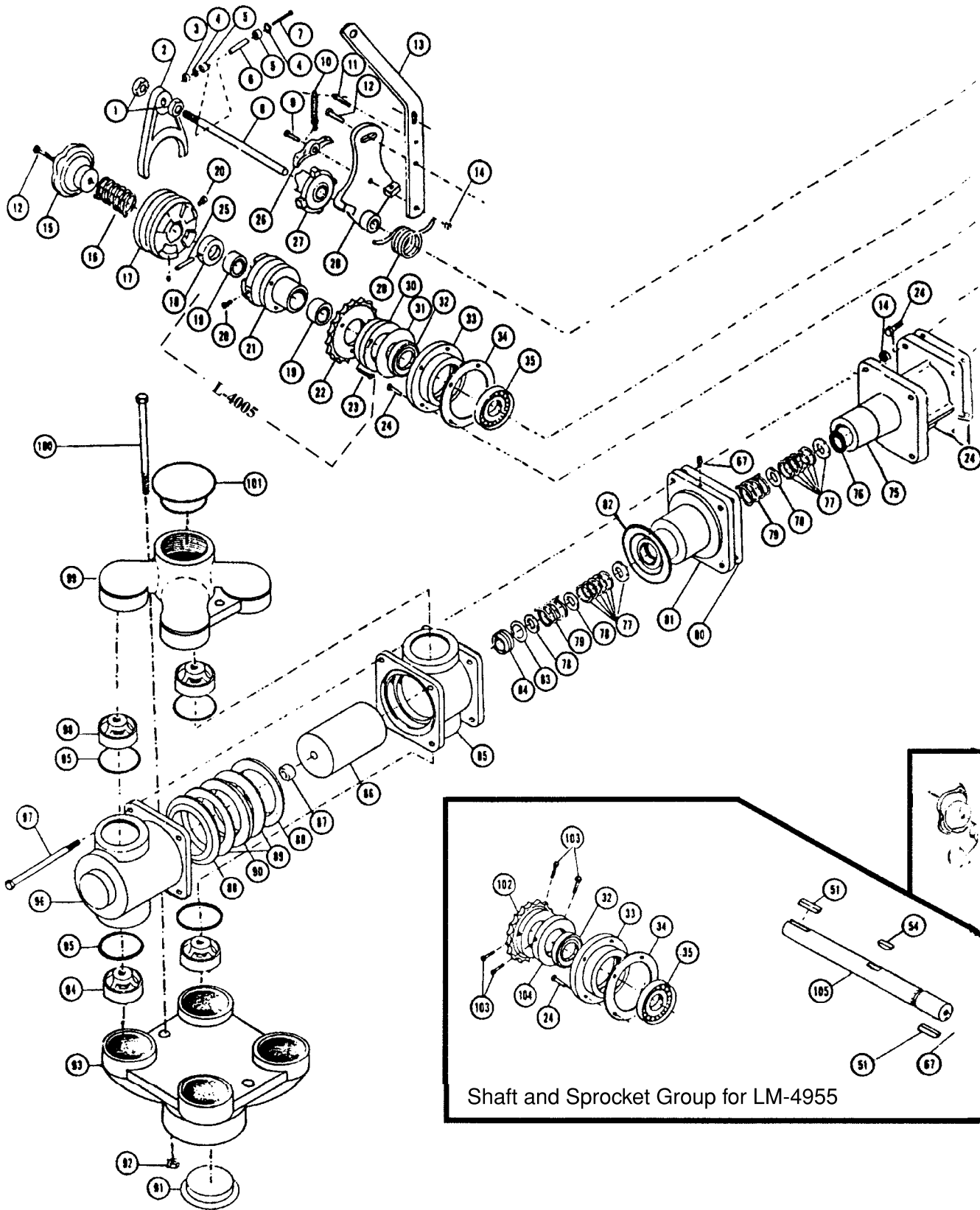

Shaft and Sprocket Group for LM-4955

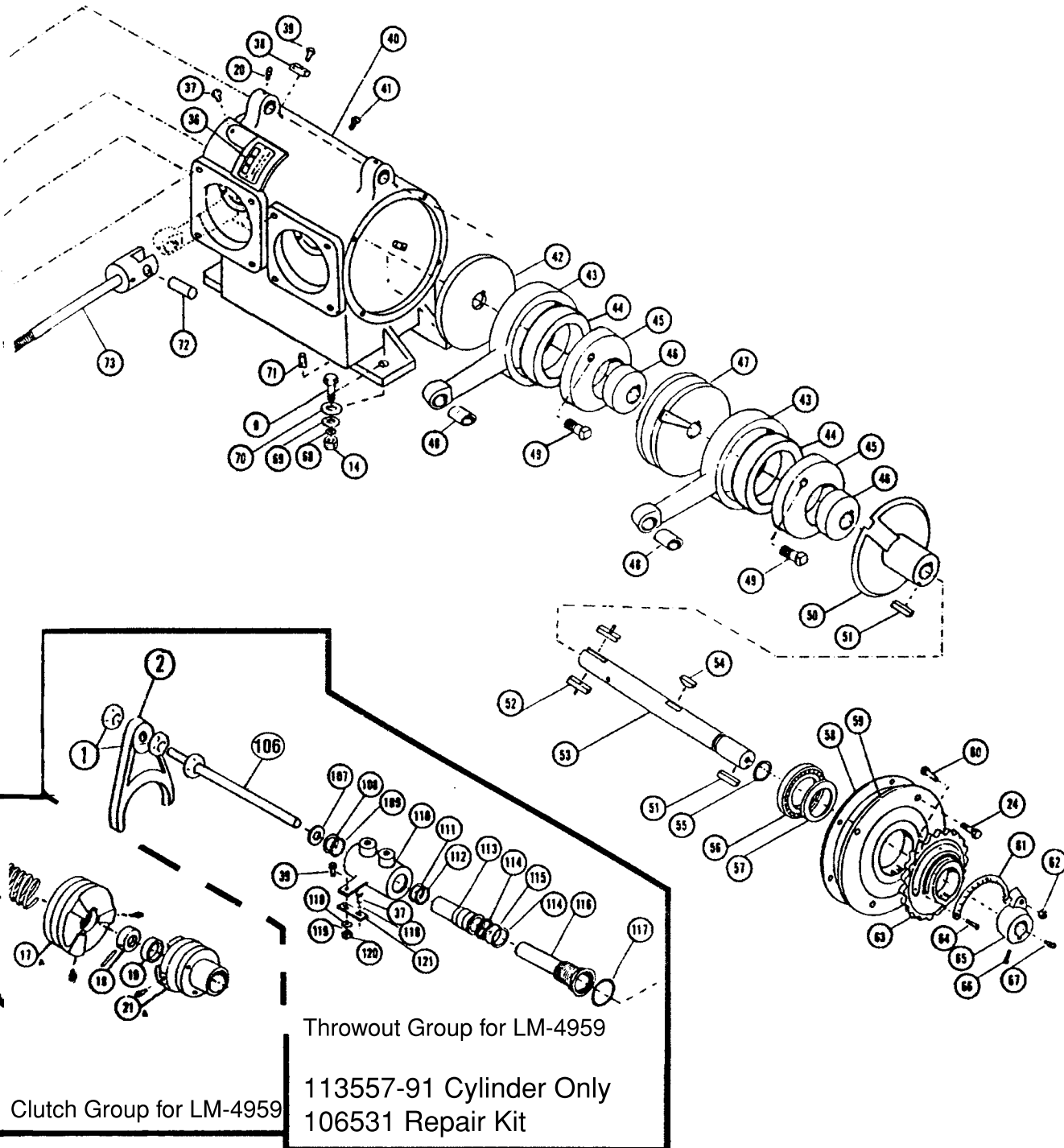

Pump Repair Kit – 111947
 Pump Setting Wrench – L-3092-AS
 Pump Setting Chart – 105913-91

LIMITED WARRANTY

THIS WARRANTY IS IN LIEU OF ALL OTHER WRITTEN OR EXPRESS WARRANTIES AND REPRESENTATIONS. ANY IMPLIED WARRANTIES INCLUDING MERCHANTABILITY OR FITNESS FOR ANY PARTICULAR PURPOSE ARE EXPRESSLY LIMITED TO THIS WRITTEN WARRANTY. CDS-JOHN BLUE COMPANY SHALL NOT BE LIABLE FOR CONSEQUENTIAL DAMAGES.

Use of this product for any purpose other than its original intent, abuse of the product, and/or any modification to the original product is strictly prohibited by the manufacturer, CDS-John Blue Company. Any modification to the product should be approved by CDS-John Blue prior to use. CDS-John Blue Company will deny Warranty claims and liability in any situation involving misuse, abuse or modification.

Each new machine or component manufactured by CDS-John Blue Company through original buyer is warranted by CDS-John Blue Company to buyer and to any party or parties to whom buyer may resell, lease or lend the equipment to be free from defects in material and workmanship under normal use and service. This obligation of CDS-John Blue Company under this warranty is limited to the repair or replacement of defective parts or correction of improper workmanship of an parts of such equipment which shall within one year from the date of CDS-John Blue's original delivery thereof, be returned to CDS-John Blue's factory, transportation charges prepaid and which CDS-John Blue Company shall determine to its satisfaction upon examination thereof to have been thus defective. When it is impractical to return the defective parts of such equipment to CDS-John Blue's factory, then CDS-John Blue shall have no liability for the labor cost involved in repairing or replacing any such parts and shall be liable solely for supplying the material necessary to replace or repair the defective parts, provided that prior thereto CDS-John Blue Company shall have determined to its satisfaction that any such parts are thus defective.

This warranty shall not apply to any equipment which shall have been repaired or altered outside CDS-John Blue's factory in any way so as to affect its durability, nor which has been subjected to misuse, abuse, negligence or accident or operated in any manner other than in accordance with operating instructions provided by CDS-John Blue Company. This warranty does not extend to repairs made necessary by the use of inferior or unsuitable parts or accessories, or parts or accessories not recommended by CDS-John Blue Company.

CDS-John Blue Company makes no warranties in respect to parts, accessories, or components not manufactured by CDS-John Blue Company, same ordinarily being warranted separately by their respective manufacturers.

DIVISION OF ADVANCED SYSTEMS TECHNOLOGIES

HUNTSVILLE, AL

(256) 721-9090

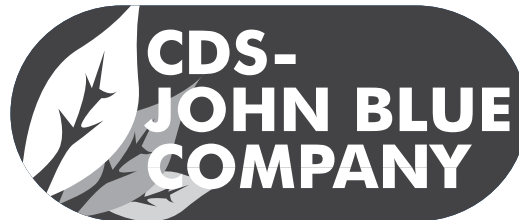

CDS-John Blue Company

Division of Advanced Systems Technology

290 Pinehurst Dr. Huntsville, AL 35806

PO Box 1607 Huntsville, AL 35807

Telephone: (256) 721-9090 • Fax (256) 721-9091 • Toll Free: 1-800-253-2583

www.cds-johnblue.com

YOUR LOCAL DEALER