



CENTRIFUGAL TRANSFER PUMPS

PARTS AND INSTRUCTION MANUAL



SP-3220 Shown

CDS-JOHN BLUE COMPANY

DIVISION OF ADVANCED SYSTEMS TECHNOLOGY, INC.

165 Electronics Blvd, Huntsville, AL 35824

Telephone: (256) 721-9090 - FAX: (256) 721-9091

Toll Free: 1-800-253-2583

Copyright 2015 CDS-John Blue Company

NOTES

SAFETY PRECAUTIONS

- Equipment should be operated only by responsible people.
- A careful operator is the best insurance against an accident.
- Fill system with WATER first and check output.
- Check all valves, fittings, hose clamps, etc. for wear / leaks before admitting process fluid to the system.
- Replace hoses when worn, cracked, or if leaking.

WARNING: USE OF THIS PRODUCT FOR ANY PURPOSES OTHER THAN ITS ORIGINAL INTENT, ABUSE OF THE PRODUCT, AND/OR MODIFICATION TO THE ORIGINAL PRODUCT IS STRICTLY PROHIBITED BY CDS-JOHN BLUE COMPANY. CDS-JOHN BLUE COMPANY RESERVES THE RIGHT TO DENY WARRANTY OR LIABILITY CLAIMS IN ANY/ALL SITUATIONS INVOLVING MISUSE, ABUSE OR MODIFICATION.

THE ORIGINAL INTENT OF THIS PRODUCT DOES NOT INCLUDE USE WHERE THE MAXIMUM ALLOWED SPEED, PRESSURE, OR TEMPERATURE IS EXCEEDED, AND IT DOES NOT INCLUDE APPLICATIONS UTILIZING FLUIDS THAT ARE NOT COMPATIBLE WITH THE PRODUCT'S COMPONENT MATERIALS. DO NOT USE THIS PRODUCT WITH FLAMMABLE OR COMBUSTIBLE FLUIDS SUCH AS GASOLINE, KEROSENE, DIESEL, ETC..., AND DO NOT USE IN EXPLOSIVE ATMOSPHERES. FAILURE TO FOLLOW THIS NOTICE MAY RESULT IN SERIOUS INJURY AND/OR PROPERTY DAMAGE AND WILL VOID THE PRODUCT WARRANTY. IF IN DOUBT ABOUT YOUR APPLICATION, CONTACT YOUR STOCKING DEALER OR THE CDS-JOHN BLUE TECHNICAL STAFF AT 1-800-253-2583.

To The Owner

This manual has been prepared and illustrated to assist you in the maintenance of your CDS – JOHN BLUE PUMP. Enter your serial number and the date of the purchase in the space provided below for future reference in service information or for ordering parts. Because our engineering department is constantly improving products, we reserve the right to make design and specification changes without notice.

Model Number: _____ Serial Number: _____ Purchase Date: _____

TABLE OF CONTENTS

Safety Precautions	3
Note to the Owner	3
Table of Contents	4
Pump Specifications and Flow Curves	5
Pump Model List.....	6
Installation	7
Maintenance	8
Storage	8
Repair	9
Hydraulic System Information	11
Parts Listings	
Straight 2"	13
Straight 3"	14
Self-Priming 2"	15
Self-Priming 3"	16
S-3325-P Pedestal	17
Close-Coupled Pedestals	18
Electric Motor and Gas Engine Models	19
Hydraulic Motor Drive Kits	20
Dimensional Information	21
Troubleshooting	22
Notes	23
Warranty	24

PUMP SPECIFICATIONS

<i>(Values are for water)</i>	S-3220	S-3320	SP-3220	SP-3320 Standard	SP-3320 High Flow	S-3325-P
Max. Attainable Flow:	197 GPM	365 GPM	152 GPM	308 GPM	327 GPM	463 GPM
Max. Attainable Pressure:	39 PSI	60 PSI	42 PSI	67 PSI	67 PSI	99 PSI
Flow @ 25 PSI:	140 GPM	310 GPM	112 GPM	261 GPM	325 GPM	43
Max. Operating Speed:	3600 RPM	3600 RPM	3600 RPM	3600 RPM	3600 RPM	4500 RPM
Max. Required Horsepower:	5 Hp	10 Hp	5 Hp	10 Hp	13 Hp	16.5 Hp
Rotation (from input side):	CW	CW	CW	CW	CW	CW
Plumbing Size:	2" FNPT	3" FNPT	2" FNPT	3" FNPT	3" FNPT	3" FNPT
Housing Configuration:	Straight	Straight	Self-Priming	Self-Priming	Self-Priming	Straight

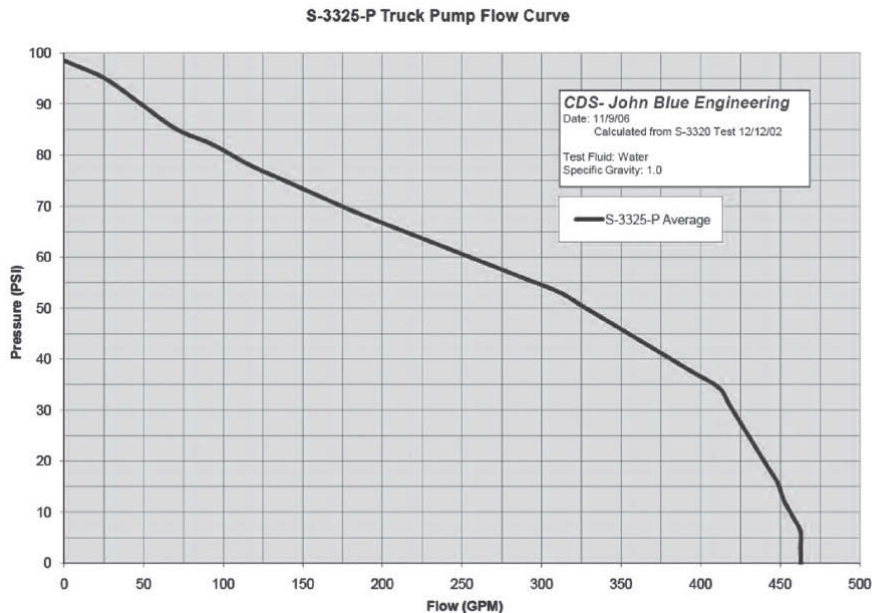
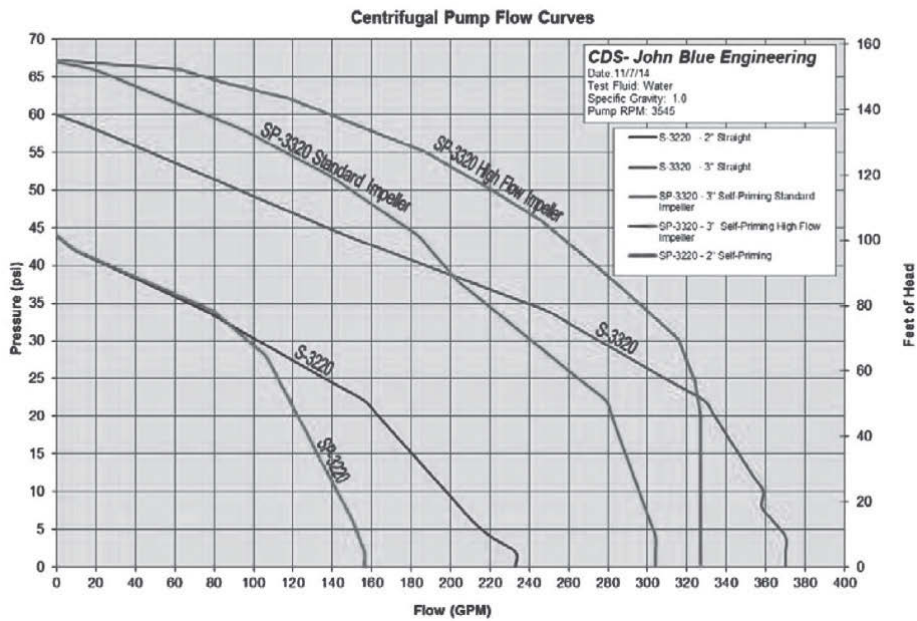

PUMP MODEL LIST

The VAC-U-SEAL line of CDS-John Blue Centrifugal Transfer Pumps is very complete and versatile in that many combinations can be assembled from available components. Due to the complex nature of the system, it is of great importance that you know the exact model of your pump, its size, straight or self priming, and material of construction when obtaining service parts or technical support. The model list and figures below will be helpful in determining the correct nomenclature for your pump.

	Pumps with Adapters for Gasoline Engines		Pumps with Adapters for Electric Motors
S-3220	2" NPT Straight Pump	S-3220-E	2" NPT Straight Pump
S-3320	3" NPT Straight Pump	SP-3220-E	2" NPT Self-Priming Pump
S-3320-BS **†	3" NPT Straight Pump (BS)	S-3320-E	3" NPT Straight Pump
SP-3220	2" NPT Self-Priming Pump	SP-3320-E	3" NPT Self-Priming Pump
SP-3320	3" NPT Self-Priming Pump	SP-3320-EX †	3" NPT Self-Priming Pump High Flow Impeller
SP-3320-BS **†	3" NPT Self-Priming Pump (BS)		
	** BS pumps accept a 1" diameter engine shaft		Pumps Coupled to Gasoline Engines
	Note: Adding "C" suffix denotes silicon carbide seals	S-3220-G5H	2" NPT Straight Pump, 5Hp Honda, w/Base
	Note: Adding "FLG" suffix denotes flanged inlet and outlet adapters	S-3220-G5LCT	2" NPT Straight Pump, 5.5hp LCT, w/ Base
		SP-3220-G5H	2" NPT Self-Priming, 5Hp Honda, w/Base
		SP-3220-G5LCT	2" NPT Self-Priming, 5.5Hp LCT, w/ Base
		SP-3320-G13H †	3" NPT Self-Priming, 13Hp Honda, Elec. Start, w/Base
		SP-3320-G13LCT †	3" NPT Self-Priming, 13Hp LCT, Elec. Start, w/Base
	Pumps Coupled to Electric Motors		Pumps with Hydraulic Drive
S-3220-E5D1	2" NPT Straight Pump, 5 Hp, 1 Phase		
S-3220-E5D3	2" NPT Straight Pump, 5 Hp, 3 Phase	S-3220-PH	2" NPT Straight Pump with Hyd. Drive, w/Base
S-3220-E5T3	2" NPT Straight Pump, 5 Hp, 3 Phase, TEFC	SP-3220-PH	2" NPT Self-Priming Pump with Hyd. Drive, w/Base
S-3320-E10T-1	3" NPT Straight Pump, 10 Hp, 1 Phase, TEFC	S-3325-PH	3" NPT Straight Pump with Hyd. Drive – 25 GPM
S-3320-E10TB-1	3" NPT Straight Pump, 10 Hp, 1 Phase, TEFC, w/Base	SP-3325-PH	3" NPT Self-Priming Pump w/Hyd. Drive– 25 GPM
S-3320-E10T	3" NPT Straight Pump, 10 Hp, 3 Phase, TEFC	S-3325-PHL	3" NPT Straight Pump w/LF Hyd. Drive – 14 GPM
S-3320-E15T †	3" NPT Straight Pump, 15 Hp, 3 Phase, TEFC	SP-3325-PHL	3" NPT Self-Priming Pump w/LF Hyd. Drive– 14 GPM
			Pumps with Pedestals
SP-3220-E5D1B	2" NPT Self-Priming Pump, 5 Hp, 1 Phase, with Base	S-3220-P	2" NPT Straight Pump with Pedestal
SP-3220-E5T1B	2" NPT Self-Priming Pump, 5 Hp, 1 Phase, with Base, TEFC	SP-3220-P	2" NPT Self-Priming Pump with Pedestal
SP-3220-E5D3B	2" NPT Self-Priming Pump, 5 Hp, 3 Phase, with Base	S-3320-P	3" NPT Straight Pump with Pedestal
SP-3220-E5T3B	2" NPT Self-Priming Pump, 5 Hp, 3 Phase, TEFC, with Base	S-3325-P	3" NPT Straight Pump for Truck mounting
SP-3320-E10TB-1	3" NPT Self-Priming Pump, 10 Hp, 1 Phase, TEFC, with Base	SP-3320-P	3" NPT Self-Priming Pump with Pedestal
SP-3320-E10TB	3" NPT Self-Priming Pump, 10 Hp, 3 Phase, TEFC, with Base	SP-3325-P	3" NPT Self-Priming Pump for Truck mounting
SP-3320-E15TB †	3" NPT Self-Priming Pump, 15 Hp, 3 Phase, TEFC, with Base		

†- Pumps Utilizing High Flow Impeller (102037-A)

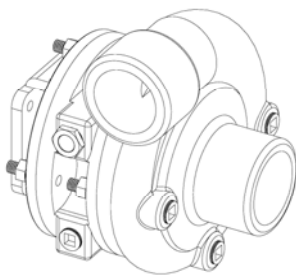

Straight

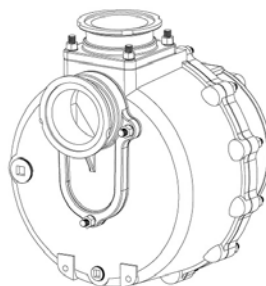

Self-Priming –
Flanged Fittings

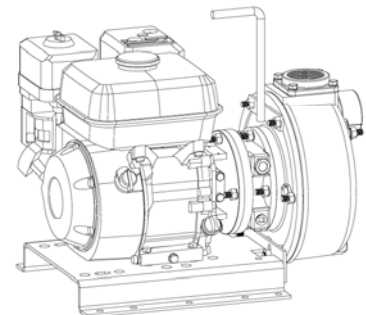

Close Coupled Gas Engine

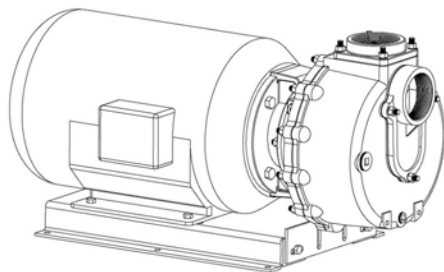

Close Coupled Electric Motor

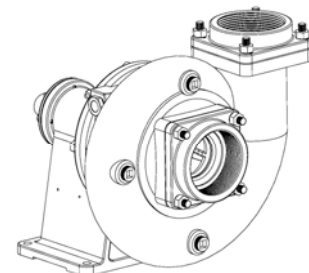

Truck Pump Pedestal – Straight Housing

INSTALLATION

MOUNTING

- The pump should be installed in a clean, dry, and well ventilated area – preferably close to the fluid supply tank.
- The pump should be mounted so that the sight window is at the top of the seal reservoir, and it may be moved to one of the other ports on the seal reservoir if necessary.
- If the seal reservoir fluid is drained for any reason, a 50/50 mixture of ethylene glycol antifreeze and water should be used to replace it, filled to half-way up the window.
- Be sure to note the direction arrow cast into the pump body, and double check your power source's rotation direction.

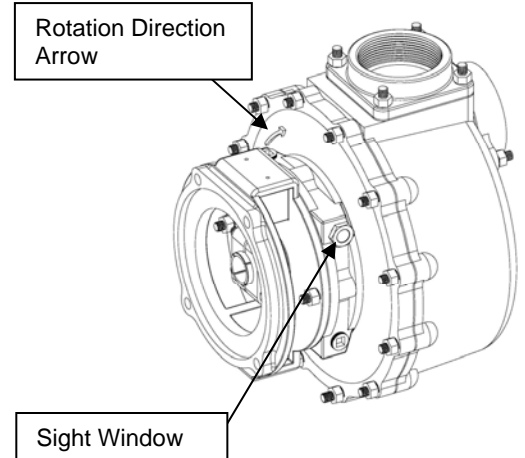

- For close-coupling to a motor, engine, or pedestal, the following must be observed:
 - Vac-U-Seal pumps must NEVER be used on engines or motors with plain bearings – ONLY use engines or motors equipped with ball bearings. Plain bearings allow the shaft to float or slide axially. The engine/motor/pedestal shaft is what supports the impeller in the housing, and it must be rigidly supported and constrained.
 - When sliding the shaft in to the pump shaft, pre-lube the shaft with a light oil and clean the shaft of all debris and burrs. NEVER FORCE THE PUMP ONTO THE SHAFT. It should slide on easily – investigate any interference.
 - When clamping the pump shaft onto the engine/motor/ Pedestal shaft, ensure that the split lines of the coupling are spaced evenly between the slits in the pump shaft.
 - Tighten the bolts of the clamp evenly so that the gaps on each side are equal.

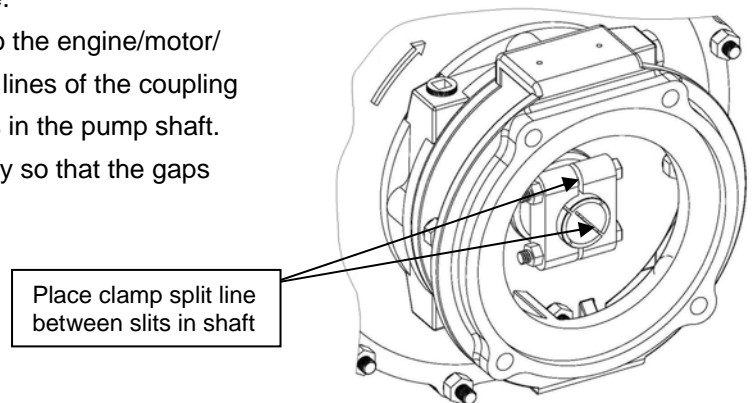

PIPING

- Vac-U-Seal pumps are not designed to support piping. If piping is used, it should be supported independently of the pump and connected to the pump with flexible members such as hose.
- It is recommended that new clean pipe be used at installation, and be of the same size as the pump ports. For long distances, the pipe size may need to be increased.
- The suction pipe should always be sloped upward to avoid creating air pockets in the line.

ELECTRICAL

- For electric motors, a licensed electrician must be used to wire the pump/motor assembly. The wire and fuses should be sized by the licensed electrician based on the motor tag data and the length of wire run.
- Do not use the pump/motor assembly in explosive atmospheres – ensure adequate ventilation.

GAS ENGINES

- For gas engines with electric start, use 6 ga cable to connect both the positive terminal of the battery to the stud on the starter solenoid, and the negative terminal of the battery to an engine mounting bolt or a good grounding point on the frame. The length of cable should be kept to a minimum, preferably 3ft or less.
- The battery used should be 12v – 18Ah or larger, and it must be securely mounted to the frame.
- Coat terminals and cable ends with grease.
- Do not use the pump/engine assembly in explosive atmospheres – ensure adequate ventilation.

MAINTENANCE

- Inspect the seal reservoir fluid level using the sight window – it should be above the middle of the window.
- If dirty, replace the fluid by draining and replacing with a 50/50 mixture of ethylene glycol antifreeze and water. The recommended service interval for this fluid is 100 hours.
- If the fluid in the seal reservoir becomes cloudy or loses fluid after use, the impeller side seal is leaking and should be replaced.
- Inspect the pump frequently for any leaks from the housing gaskets or shaft seal.

STORAGE

**** IMPORTANT – KEEP AIR OUT OF THE PUMP AND KEEP FROM FREEZING****

- Keep air out of the pump! This is the only way to prevent corrosion. Even for short periods of storage, the entrance of air into the pump causes RAPID and SEVERE CORROSION. Freezing temperatures can cause the fluid or water to freeze internally to the pump, which can cause severe damage to castings.
- **To prevent excessive corrosion of the pump's cast iron components:**
 - Flush pump thoroughly with 5 to 10 gallons of a solution that will neutralize the liquid last pumped (refer to that manufacturer's instructions). Fill with clean water and DO NOT DRAIN. Keep pump sealed to exclude air by placing plugs in the suction and discharge lines to keep pump full. For long-term storage (more than 2 weeks), use straight RV-antifreeze (which has a corrosion inhibitor) to fill the pump after flushing.
- **To protect pump from freezing:**
 - Flush pump per instructions above and IMMEDIATELY fill pump with straight RV-antifreeze. Place plugs in the suction and discharge lines to keep pump full and exclude air.

REPAIR

SEAL REPLACEMENT

- * Be sure to order the correct seal for your pump: **Ceramic** (white seat sealing surfaces) or **Carbide** (gray)
- * Gasket and seal kits may also be purchased to rebuild pump – see Parts Listing section

- 1.) Loosen the shaft clamp, and unbolt the pump adapter from the engine/motor/pedestal. Penetrating oil should be allowed to soak between pump shaft and the driving shaft if it is stuck.
- 2.) Carefully remove the pump from the engine/motor/pedestal by pulling it straight off of the shaft. Do not pry the pump back and forth, as it may bend the tabs of the pump shaft.
- 3.) Disassemble the pump by draining the seal reservoir fluid, and then removing the motor/engine adapter and the reservoir housing.
- 4.) Remove the seal seats from the pump castings, and carefully clean the counterbores where they fit.
- 5.) When re-installing new seal seats, coat the rubber o.d. with a quality pipe compound like Rector Seal, and press the seal seat fully into the casting counterbores. The compound will lubricate the seat for installation and prevent corrosion under the seal.
- 6.) Using a small hammer and a plastic tube or block on the seal seat, you may lightly tap the seats into the counterbores to make sure they are bottomed out fully.
- 7.) Before re-assembly, make sure the ceramic faces (where the rotary seal will touch) are clean.
- 8.) Thoroughly clean the shaft and lightly lubricate it with oil or grease before installing the shaft seals and spring onto the shaft.
- 9.) Assemble the pump using new rubber gaskets between the casting components and replace impeller wear rings as necessary. Note: Wear rings fit very tightly and must be stretched by hand before being rolled onto the parts.
- 10.) Re-install the anti-freeze/water mixture as described in the Maintenance section.

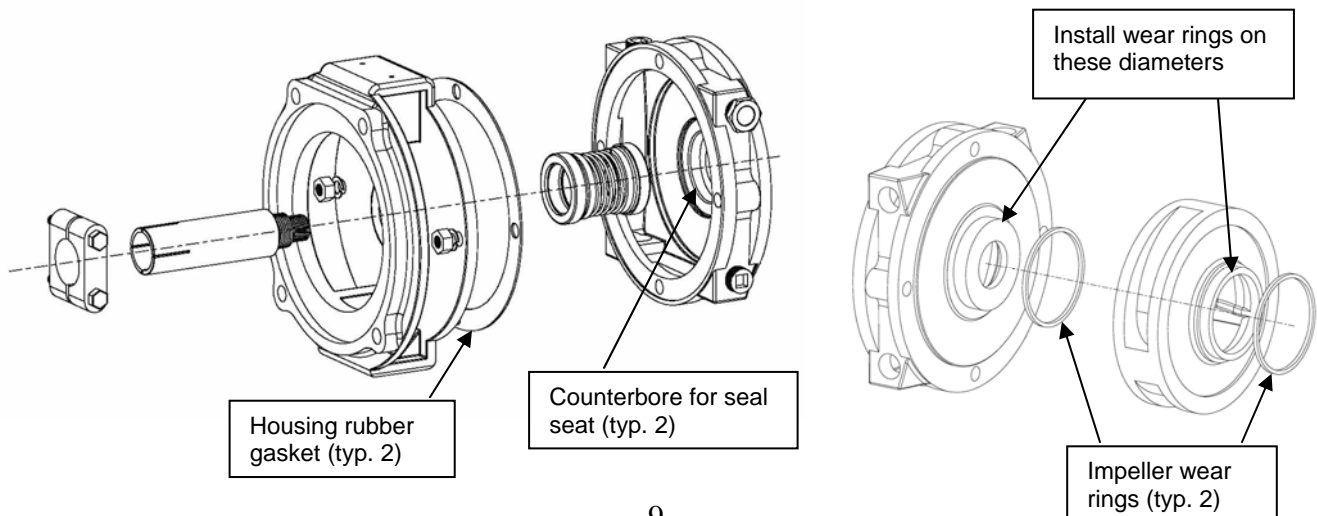

IMPELLER REPLACEMENT (refer to the appropriate parts listing for your model):

- 2" pumps: Remove plumbing from the pump, and then the (4) nuts holding the pump housing to the seal reservoir on a straight pump, or (6) nuts holding the housing to the housing back cover on the self-priming. Remove housing. Hold the pump shaft stationary, and first unscrew the impeller locknut, then the impeller itself (both have right-hand threads) using a large screwdriver inserted in the vanes.
 - Be sure to use new rubber gaskets when re-assembling the pump.
 - It is also recommended to replace the two Teflon wear rings on the impeller
- 3" self-priming pumps: Use the same instructions as above, except that there are (12) nuts holding the pump housing to the housing back cover.
- 3" straight pumps (including the S-3325-P Truck Pump): Because the studs attaching the pump housing extend through the seal reservoir, the reservoir must be drained before the (4) nuts are removed and the pump pulled apart. Replace all rubber gaskets when re-assembling. Fill the reservoir per the instructions given in the Maintenance section.

PEDESTAL BEARING/SHAFT REPLACEMENT (refer to the appropriate parts listing for your model):

- 2" pumps: The shaft and bearings of the 2" pedestal must be replaced as an assembly, and it must be pressed out through the pump side of the pedestal.
- 3" pumps: The shaft or bearings may be replaced independently of each other. The bearing cap must be removed after removing the (3) bolts retaining it. The shaft and bearings may now be pressed out through the pump side of the housing.
- S/SP-3325-P Truck Pumps: The pump must be disassembled (see impeller removal instructions above) prior to replacing the bearings and/or shaft.

HYDRAULIC CIRCUIT INFORMATION

INSTALLATION INFORMATION

- Hydraulically driven pumps require a pedestal assembly to accept the motor adapter. If you are converting an existing pump without a pedestal, one will have to be obtained.
- The hydraulic motor is attached to the pedestal using a motor adapter and a flexible coupling.
- The hydraulic motor high pressure inlet port is marked “IN”, “P”, or “PR” (pressure), and the outlet or return is usually marked “OUT” or “TK” (tank).

- The hydraulic motor requirements for driving 2” pumps are: 6 GPM min, 1000 psi min, CCW Rot.
 - Hydraulic drive kit: 110345 (contains 110346-01 motor, S-3601 adapter, and hardware)
 - Kit installs on the S-3342 2” pump pedestal

- The hydraulic motor requirements for driving 3” pumps depend on which motor is selected:
 - Hydraulic drive kit: **115910-91** (contains 107030-**02** motor, 107016-02 adapter, and hardware)
 - 25 GPM min, 1500 psi min, CCW Rot.
 - Hydraulic drive kit: **115910-91L** (contains 107030-**03** motor, 107016-02 adapter, and hardware)
 - 14 GPM min, 1500 psi min, CCW Rot.
 - Both kits install onto the S/SP-3325-P 3” truck pump pedestal

CHECK VALVE

- The hydraulic motor must be equipped with an in-line check valve at its outlet to protect the motor seals in the event the return hose is pressurized. It is recommended that a low pressure oil return is used.

TRACTOR CONTROL VALVE

- The tractor valve lever for any of the types of tractor hydraulic systems (listed below) must be locked in the open position for operation of the pump.
- If the tractor control valve is used to start and stop the pump on a closed-center hydraulic system, it is possible to create damaging pressure spikes because the valve can block the return port while the motor is running (creating a pressure spike in that line from the motor/pump momentum). Alternatives to prevent pressures spikes are adding an in-line start-stop valve, or setting the tractor system to “float” when turning off the flow to the motor.

TRACTOR HYDRAULIC SYSTEM TYPES

- There are three types of tractor hydraulic systems available today:

OPEN CENTER SYSTEM

- Open center systems utilize a constant flow pump
- This requires the use of an in-line **by-pass valve** to control the speed of the hydraulic motor. (Note: The 2" pump motor (110346-01) has a built-in bypass valve, and it is adjusted using the slotted shaft and locknut on the side of the motor.)
- If a large amount of oil is bypassed when running the pump motor, a significant amount of heat can be generated in the oil, which could damage the tractor's hydraulic system.
- Auxiliary cooling or reducing the engine speed may be necessary to avoid damage.

CLOSED CENTER PRESSURE COMPENSATED SYSTEM

- Closed center pressure compensated systems utilize a variable stroke pump that increases the flow rate until a certain pressure is reached, at which point the flow rate remains constant.
- In order to operate the pump hydraulic motor at the proper speed, pressure must be built-up against the pump to restrict its rate of flow, so a restriction must be added before the motor inlet.
- This may be accomplished in two ways: with a **needle valve** in-line before the motor inlet port, or with an **in-line orifice** before the motor inlet port. It is important to install the orifice before the inlet port only, because damage to the motor may result if it is installed in the outlet.
- The speed of the pump may then be adjusted with the tractor's flow control valve.
- Do not use a by-pass valve with a pressure compensated closed center system.
- When turning off flow to the motor using the tractor control valve, the controls must be set to the float position to prevent pressure spikes.

CLOSED CENTER LOAD SENSING SYSTEM

- Closed center load sensing systems are similar to the pressure compensated systems, except that they have flow compensation too, which results in less heat generation and higher efficiency.
- The speed of the pump will be adjusted with the tractor's flow control valve.
- Do not use a by-pass valve or an orifice with a load sensing closed center system.
- When turning off flow to the motor using the tractor control valve, the controls must be set to the float position to prevent pressure spikes.

PARTS LISTING: S-3220 (2" STRAIGHT)

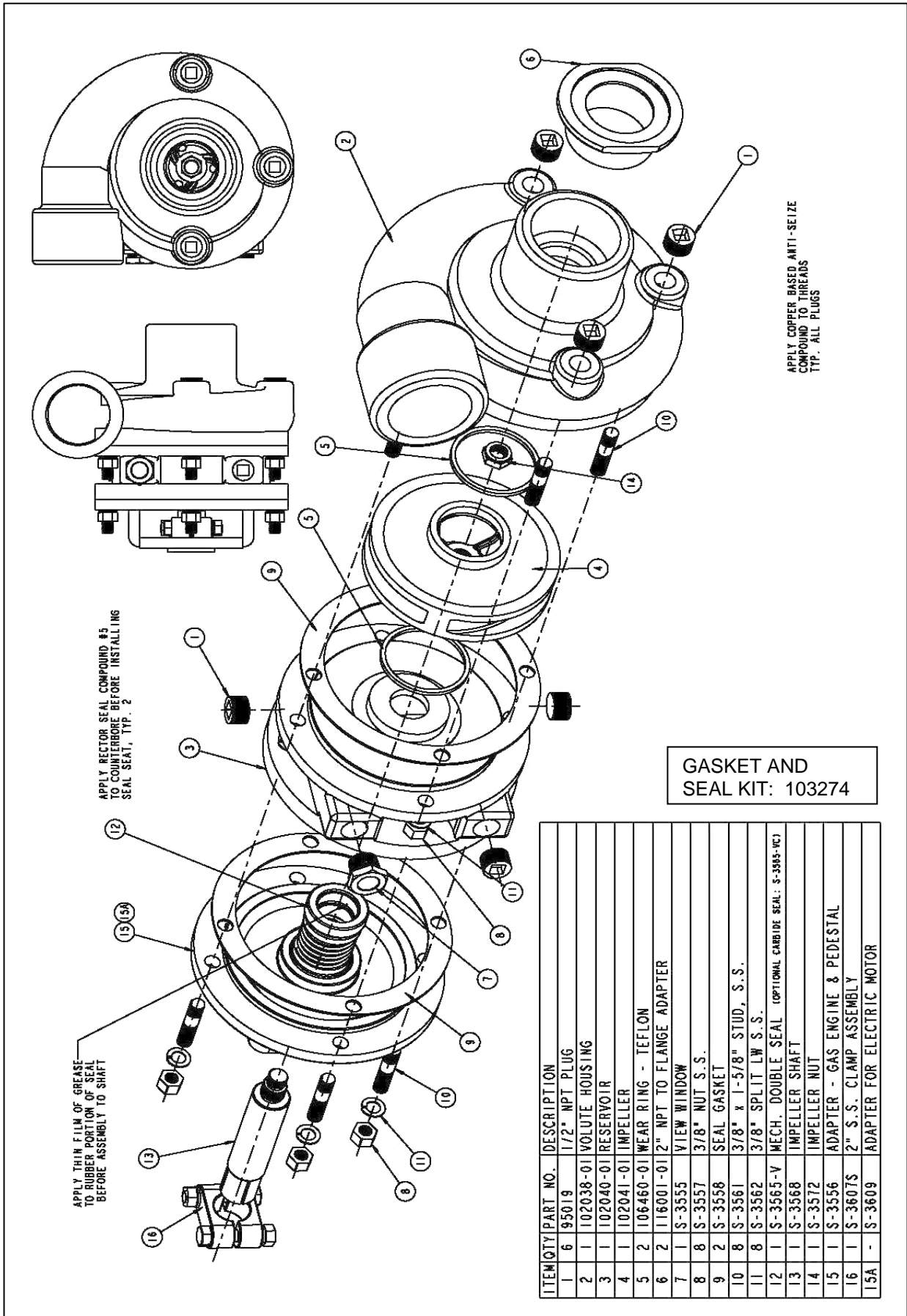

GASKET AND SEAL KIT: 103274

ITEM QTY	PART NO.	DESCRIPTION
1	6	95019 1/2" NPT PLUG
2	1	102038-01 VOLUTE HOUSING
3	1	102040-01 RESERVOIR
4	1	102041-01 IMPELLER
5	2	106460-01 WEAR RING - TEFLON
6	2	116001-01 2" NPT TO FLANGE ADAPTER
7	1	S-3535 VIEW WINDOW
8	8	S-3557 3/8" NUT S.S.
9	2	S-3558 SEAL GASKET
10	8	S-3561 3/8" x 1-5/8" STUD, S.S.
11	8	S-3562 3/8" SPLIT LW S.S.
12	1	S-3565-V MECH. DOUBLE SEAL (OPTIONAL CARBIDE SEAL: S-3565-VC)
13	1	S-3568 IMPELLER SHAFT
14	1	S-3572 IMPELLER NUT
15	1	S-3536 ADAPTER - GAS ENGINE & PEDESTAL
16	1	S-3607S 2" S.S. CLAMP ASSEMBLY
15A	-	S-3609 ADAPTER FOR ELECTRIC MOTOR

PARTS LISTING: S-3320 (3" STRAIGHT)

APPLY THIN FILM OF GREASE TO RUBBER PORTION OF SEAL BEFORE ASSEMBLY TO SHAFT

APPLY RECTOR SEAL COMPOUND #5 TO COUNTERBORE BEFORE INSTALLING SEAL SEAT, TYP. 2

APPLY COPPER BASED ANTI-SEIZE COMPOUND TO THREADS TYP. ALL PLUGS

GASKET AND SEAL KIT: 103277

ITEM QTY	PART NO.	DESCRIPTION
1	43005	MECH. DOUBLE SEAL (OPTIONAL CARBIDE SEAL: 43011)
2	12	93025 3/8" LOCKWASHER, S. S.
3	6	95019 1/2" NPT PLUG
4	1	102034-01 VOLUTE HOUSING
5	1	102035-01 RESERVOIR
6	1	102037-01 IMPELLER
7	2	110152-01 ANNULAR SEAL
8	1	S-3555 VIEW WINDOW
9	12	S-3557 3/8" NUT S. S.
10	8	S-3561 3/8" x 1-578" STUD, S. S.
11	2	S-3638 GASKET SEAL
12	1	S-3649 3/4"-16 LEFT HAND LOCKNUT
13	2	S-3656 FLANGE GASKET
14	2	S-3657 3" F. P. T. DISCHARGE FLANGE
15	1	S-3657-FLG FLANGED ADAPTER
16	4	S-3664 3/8" x 3-1/2" STUD, S. S.
17	1	S-3646 IMPELLER SHAFT
18	1	102189-01 ADAPTER FOR GAS ENGINE
19	1	S-3608S 3" S. S. CLAMP ASSEMBLY
17A	-	114524-01 IMPELLER SHAFT FOR "BS" GAS ENGINE MODEL
18A	-	102190-01 ADAPTER FOR ELECTRIC MOTOR
18B	-	114523-01 ADAPTER FOR "BS" GAS ENGINE MODEL
19A	-	S-3608AS 3" S. S. KEYED CLAMP FOR "BS" IMPELLER SHAFT

PARTS LISTING: SP-3220 (2" SELF-PRIMING)

GASKET AND SEAL KIT: 103276

APPLY RECTOR SEAL COMPOUND #5 TO COUNTERBORE BEFORE INSTALLING SEAL SEAT, TYP. 2

APPLY THIN FILM OF GREASE TO RUBBER PORTION OF SEAL BEFORE ASSEMBLY TO SHAFT

APPLY COPPER BASED ANTI-SEIZE COMPOUND TO THREADS TYP. ALL PLUGS

BOTTOM 2 STUDS ONLY

ITEM QTY	PART NO.	DESCRIPTION
1	4	95019 1/2" NPT PLUG
2	1	102039-01 SCROLL PLATE
3	1	102040-01 RESERVOIR
4	1	102041-01 IMPELLER
5	2	106480-01 WEAR RING - TEFLON
6	2	L-4135 1/4" X 3/4" ROLL PIN, S.S.
7	1	S-3551 2" F.P.T. OUTLET (OPTIONAL 1-1/2" NPT OUTLET: S-3492)
8	1	S-3551-FLG 2" DISCHARGE FLANGE
9	1	S-3552 FLANGE GASKET
10	4	S-3553 5/16" - 18NC x 1" LG. HHCS, SS
11	4	S-3554 5/16" LOCKWASHER, SS
12	1	S-3555 VIEW WINDOW
13	17	S-3557 3/8" NUT S.S.
14	2	S-3558 SEAL GASKET
15	1	S-3559 HOUSING COVER
16	15	S-3561 3/8" x 1-5/8" STUD, S.S.
17	17	S-3562 3/8" SPLIT LW S.S.
18	1	S-3565-V MECH. DOUBLE SEAL (OPTIONAL CARBIDE SEAL: S-3565-VC)
19	1	S-3568 IMPELLER SHAFT
20	1	S-3569 2" F.P.T. SUCTION FLANGE
21	1	S-3569-FLG 2" SUCTION FLANGE
22	1	S-3570 SUCTION FLANGE GASKET
23	1	S-3572 IMPELLER NUT
24	1	S-3577 GASKET
25	1	S-3580 HOUSING
26	1	S-3581 HOUSING GASKET
27	1	S-3556 ADAPTER - GAS ENGINE & PEDESTAL
28	2	S-3597 3/8" x 2" STUD, S.S.
29	1	S-3607S 2" S.S. CLAMP ASSEMBLY
29A	-	S-3609 ADAPTER - ELECTRIC MOTOR

PARTS LISTING: SP-3320 (3" SELF-PRIMING)

GASKET AND SEAL KIT: 103278

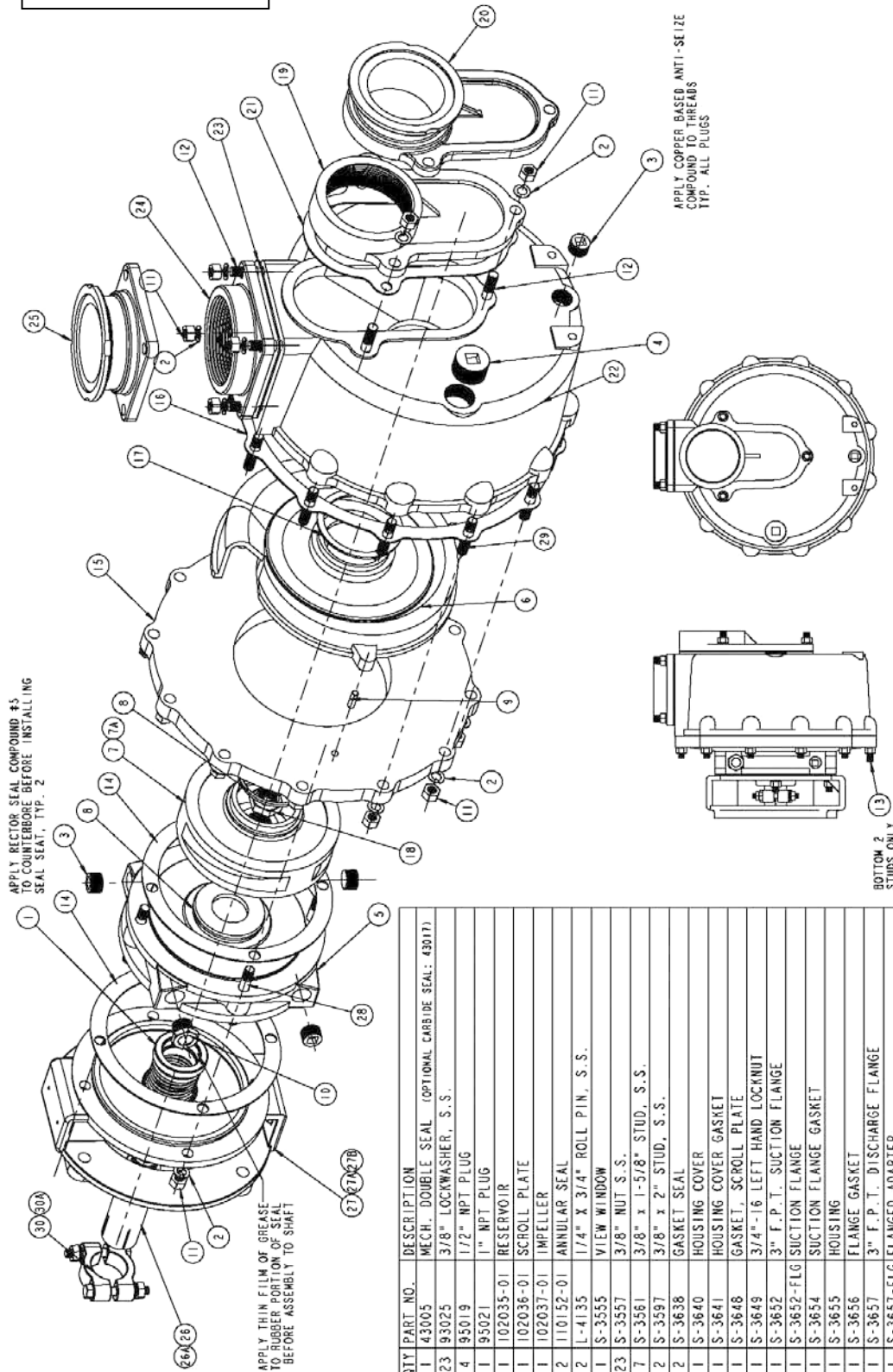

ITEM QTY	PART NO.	DESCRIPTION
1	43005	MECH. DOUBLE SEAL (OPTIONAL CARBIDE SEAL: 43017)
2	23	3/8" LOCKWASHER, S.S.
3	4	95019 1/2" NPT PLUG
4	1	95021 1" NPT PLUG
5	1	102035-01 RESERVOIR
6	1	102036-01 SCROLL PLATE
7	1	102037-01 IMPELLER
8	2	110152-01 ANNULAR SEAL
9	2	L-4135 1/4" X 3/4" ROLL PIN, S.S.
10	1	S-3555 VIEW WINDOW
11	23	S-3557 3/8" NUT S.S.
12	7	S-3561 3/8" x 1-5/8" STUD, S.S.
13	2	S-3597 3/8" x 2" STUD, S.S.
14	2	S-3638 GASKET SEAL
15	1	S-3640 HOUSING COVER
16	1	S-3641 HOUSING COVER GASKET
17	1	S-3648 GASKET, SCROLL PLATE
18	1	S-3649 3/4"-16 LEFT HAND LOCKNUT
19	1	S-3652 3" F.P.T. SUCTION FLANGE
20	1	S-3652-FLG SUCTION FLANGE
21	1	S-3654 SUCTION FLANGE GASKET
22	1	S-3655 HOUSING
23	1	S-3656 FLANGE GASKET
24	1	S-3657 3" F.P.T. DISCHARGE FLANGE
25	1	S-3657-FLG FLANGED ADAPTER
26	1	S-3646 IMPELLER SHAFT, 1-1/8"
27	1	102189-01 ADAPTER, GAS ENGINE
28	4	S-3664 3/8" x 3-1/2" STUD, S.S.
29	10	S-3666 3/8" x 1-7/8" STUD, S.S.
30	1	S-3608S 3" S.S. CLAMP ASSEMBLY
7A	-	102037-A HIGH FLOW IMPELLER
26A	-	114524-01 IMPELLER SHAFT FOR "BS" GAS ENGINE MODEL
27A	-	102190-01 ADAPTER FOR ELECTRIC MOTOR
27B	-	114523-01 ADAPTER FOR "BS" GAS ENGINE MODEL
30A	-	S-3608AS 3" METED STAINLESS CLAMP FOR "BS" IMPELLER SHAFT

PARTS LISTING: S-3325-P TRUCK PUMP PEDESTAL (USED WITH 3" STRAIGHT OR SELF-PRIMING PUMPS)

S-3325 TRUCK PUMP GASKET
AND SEAL KIT: 110128

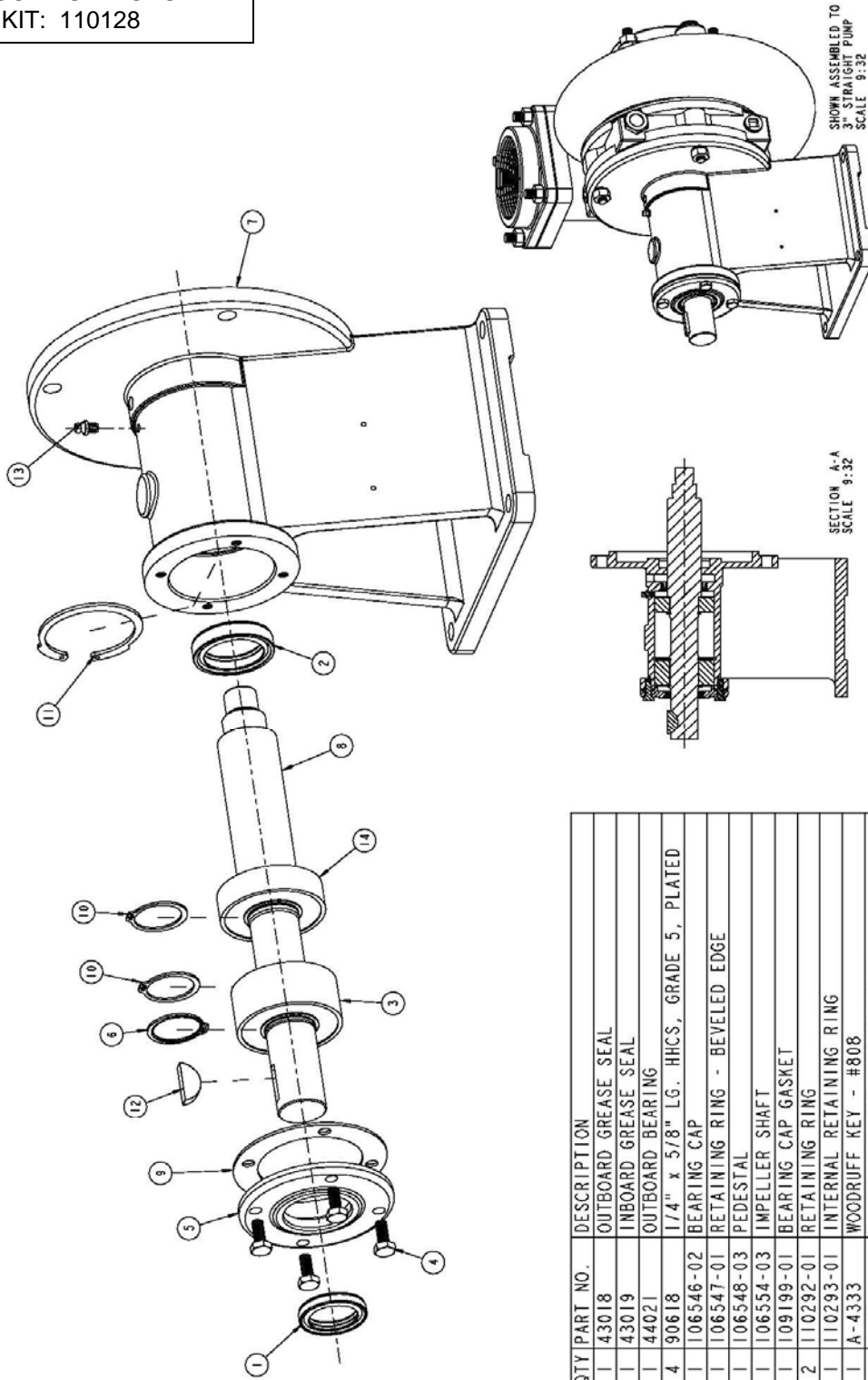

ITEM QTY	PART NO.	DESCRIPTION
1	43018	OUTBOARD GREASE SEAL
2	43019	INBOARD GREASE SEAL
3	44021	OUTBOARD BEARING
4	90618	1/4" x 5/8" LG. HHCS, GRADE 5, PLATED
5	106546-02	BEARING CAP
6	106547-01	RETAINING RING - BEVELED EDGE
7	106548-03	PEDESTAL
8	106554-03	IMPELLER SHAFT
9	109199-01	BEARING CAP GASKET
10	110292-01	RETAINING RING
11	110293-01	INTERNAL RETAINING RING
12	A-4333	WOODRUFF KEY - #808
13	H-28	GREASE FITTING, DRIVE TYPE
14	S-3634	INBOARD BEARING

PARTS LISTING: CLOSE-COUPLED PEDESTALS

2" PUMP PEDESTAL S-3342

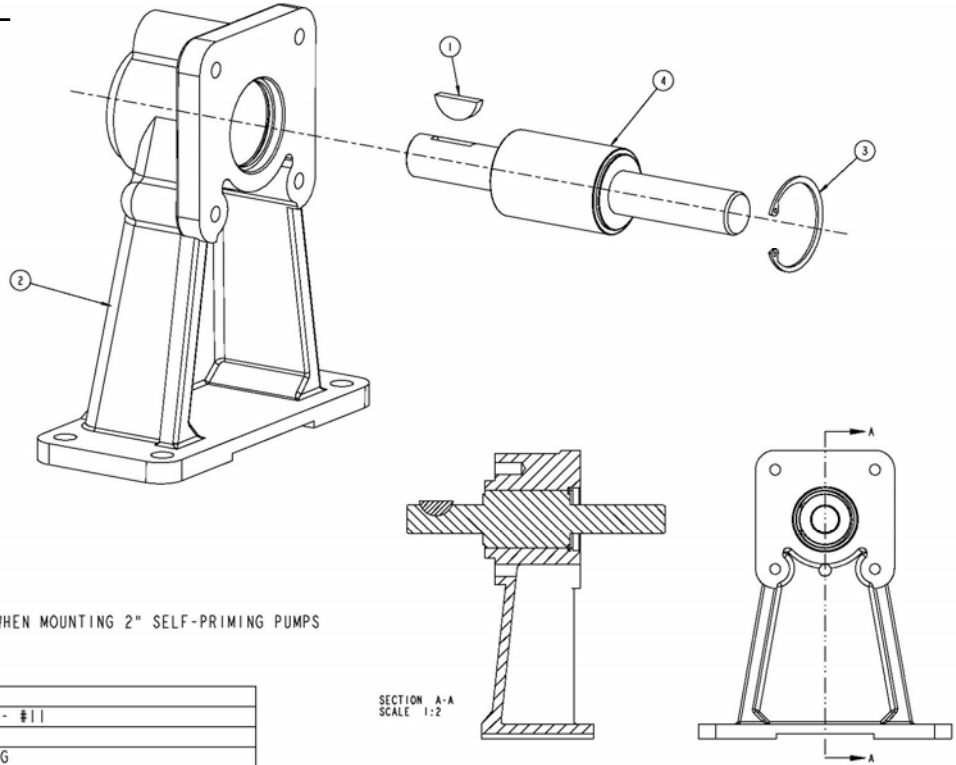

NOTE FOR SELF-PRIMING PUMPS:
USE S-3573 ANGLE BRACKET WHEN MOUNTING 2" SELF-PRIMING PUMPS

ITEM	QTY	PART NO.	DESCRIPTION
1	1	S-3583	WOODRUFF KEY - #11
2	1	S-3584	PEDESTAL
3	1	S-3585	RETAINING RING
4	1	S-3586	BEARING AND SHAFT ASSEMBLY

3" PUMP PEDESTAL S-3334

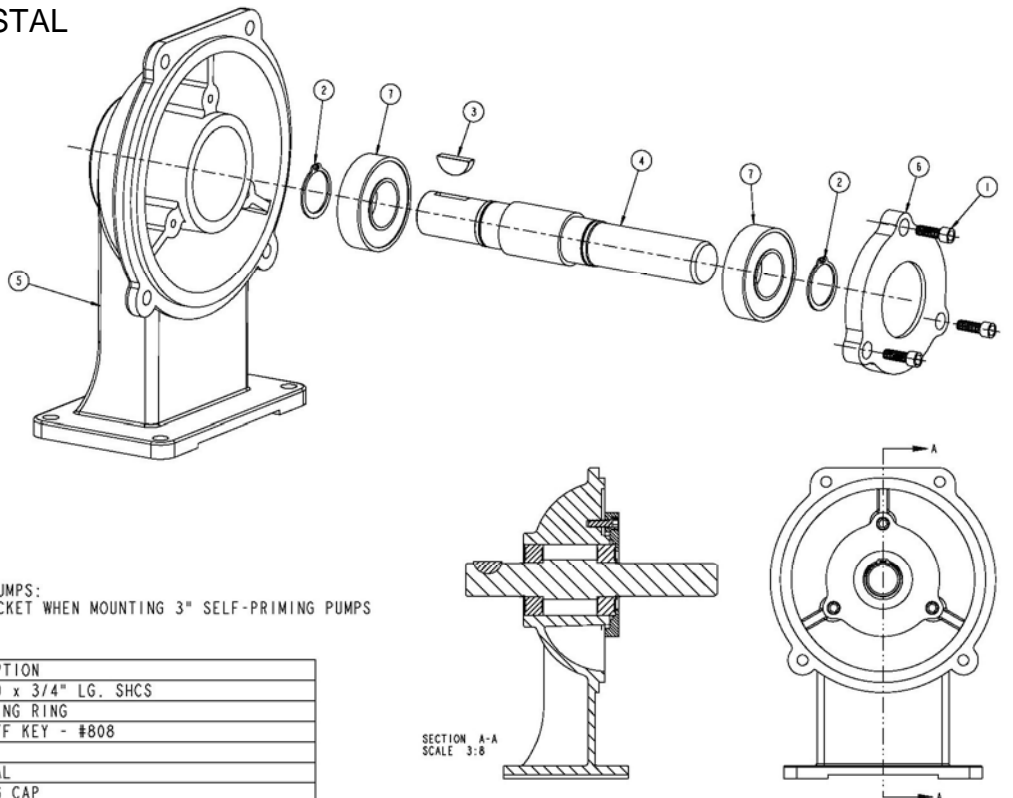

NOTE FOR SELF-PRIMING PUMPS:
USE S-3667 ANGLE BRACKET WHEN MOUNTING 3" SELF-PRIMING PUMPS

ITEM	QTY	PART NO.	DESCRIPTION
1	3	90514	1/4"-20 x 3/4" LG. SHCS
2	2	110292-01	RETAINING RING
3	1	A-4333	WOODRUFF KEY - #808
4	1	S-3630	SHAFT
5	1	S-3632	PEDESTAL
6	1	S-3633	BEARING CAP
7	2	S-3634	INBOARD BEARING

PARTS LISTING: ELECTRIC MOTOR & GAS ENGINE MODELS

(A) 2" PUMP W/GAS OR ELEC.

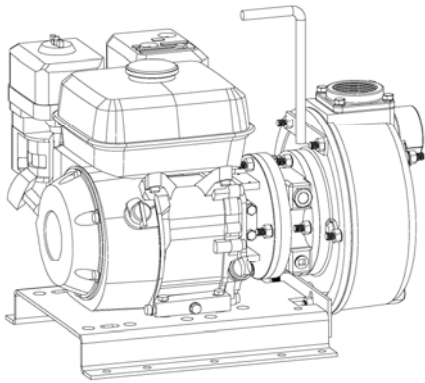

(B) 3" PUMP W/10HP ELEC.

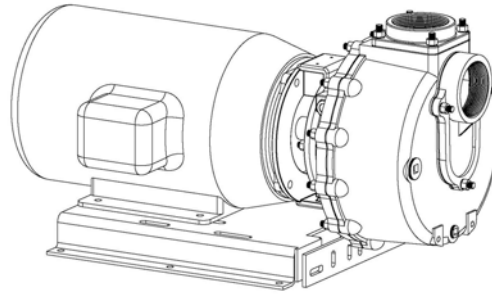

(B) 3" PUMP W/13HP GAS

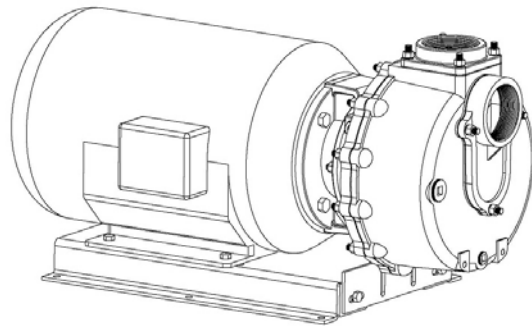

(C) 3" PUMP W/15HP ELEC.

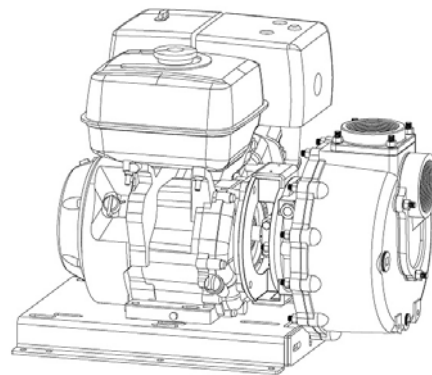

MODEL	PART #	DESCRIPTION
A	S-3321	BASE KIT - 2" PUMP FOR ELEC. MOTOR OR GAS ENGINE (INCLUDES S-3595, S-3596, MOUNTING HARDWARE)
	S-3595	BASE - 2" PUMP W/ELEC. MOTOR OR GAS ENGINE
	S-3596	PUMP HANDLE - USED WITH 2" SP PUMP
	C-5962 / C-5960	5HP ELECTRIC MOTOR, DRIP-PROOF (3PH / 1PH)
	C-5963 / C-5961	5HP ELECTRIC MOTOR, TEFC (3PH / 1PH)
	113798-01	5.5 HP HONDA GAS ENGINE
	116056-01	5.5 HP LCT GAS ENGINE
B	S-3336	BASE KIT - 3" PUMP FOR 10 HP ELECTRIC MOTOR OR GAS ENGINE (INCLUDES 108130-91, 108131-01, MOUNTING HARDWARE)
	108130-91	BASE - 3" PUMP W/ELEC. MOTOR OR GAS ENGINE
	108131-01	SUPPORT PLATE - USED FOR 3" SP PUMP W/10 HP MOTOR & GAS
	C-517 / 115277-01	10HP ELECTRIC MOTOR, TEFC (3PH / 1PH)
	115457-01	13HP HONDA GAS ENGINE
	116057-01	13HP LCT GAS ENGINE
C	108129	BASE KIT - 3" PUMP FOR 15 HP ELECTRIC MOTOR (INCLUDES 108130-91, 108127-01, MOUNTING HARDWARE)
	108130-91	BASE - 3" PUMP W/ELEC. MOTOR OR GAS ENGINE
	108127-01	SUPPORT PLATE - USED FOR 3" SP PUMP W/15 HP MOTOR
	108128	15HP ELECTRIC MOTOR, TEFC, 3PH

PARTS LISTING: HYDRAULIC MOTOR DRIVE KITS

2" PUMP HYDRAULIC MOTOR DRIVE KIT 110345

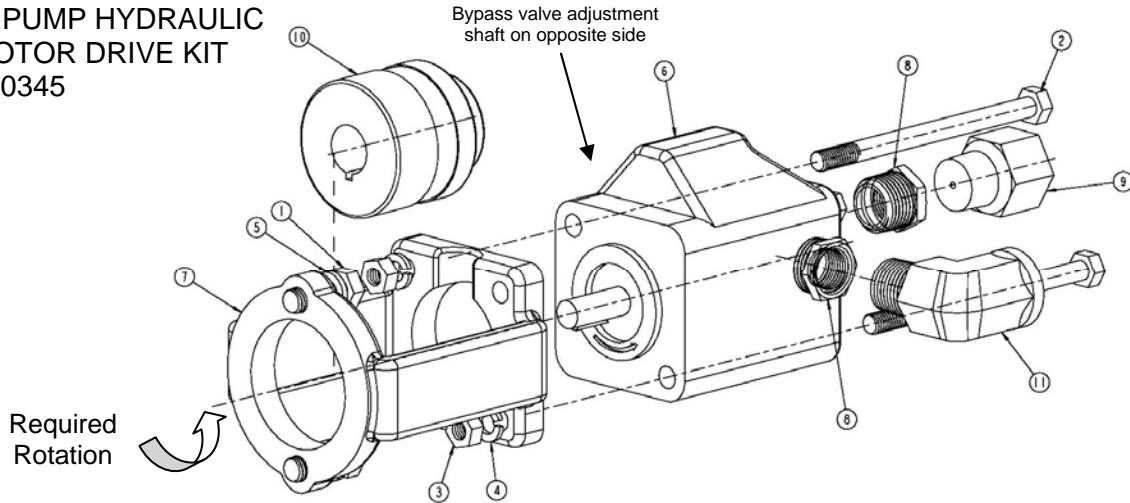

ITEM	QTY	PART NO.	DESCRIPTION
1	2	90651	3/8"-16NC X 1" LG. HEX HEAD BOLT
2	2	90959	5/16"-18NC X 4-1/2" LG. HEX HEAD BOLT
3	2	92020	3/8"-16NC HEX NUT
4	2	93023	5/16" SPLIT LW, PLTD.
5	2	93024	3/8" SPLIT LW, PLTD.
6	1	110346-01	2" PUMP HYDRAULIC MOTOR
7	1	S-3601	HYD. MOTOR ADAPTER
8	2	S-3682	REDUCING CONNECTOR, 1/2 X 3/8 NPT
9	1	S-3684	ORIFICE FITTING, 3/32"
10	1	S-3686	SHAFT COUPLING, 7/16" X 3/4"
11	1	S-8411	1/2" STEEL ELBOW

HYDRAULIC MOTOR DETAILS:

COUNTER-CLOCKWISE (CCW) ROTATION
 4-BOLT 4F17 FLANGE
 3400 RPM MAX 1000 PSI MAX CONT.
 0.00149 GAL/REV
 3/8" NPT INLET AND OUTLET PORTS
 7/16" DIAMETER x 1.13" LONG SHAFT
 APPROX. 5 GPM REQUIRED AT 3400 RPM

3" PUMP HYDRAULIC MOTOR DRIVE KITS 115910-91 - 25 GPM 15910-91L - 14 GPM

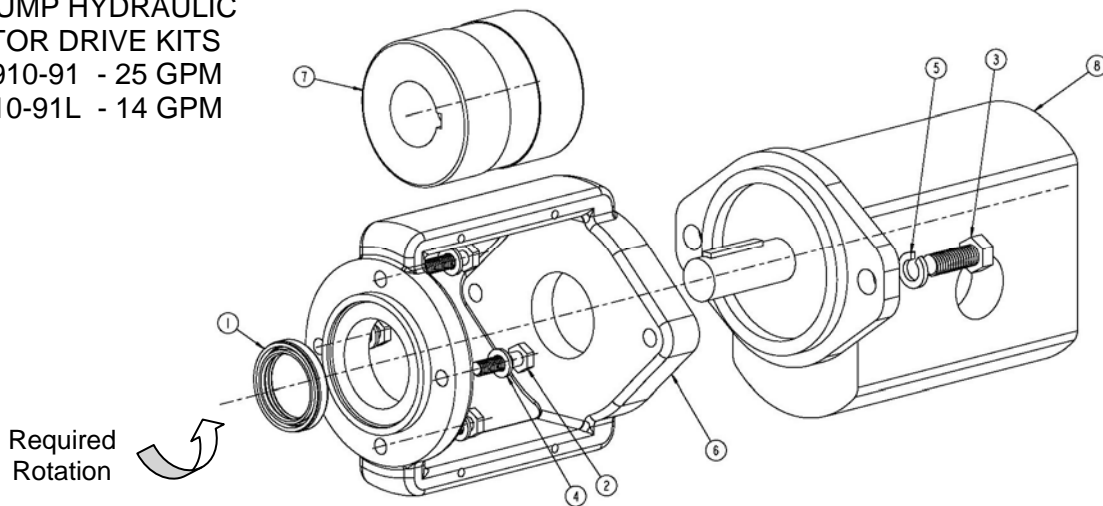

ITEM	QTY	PART NO.	DESCRIPTION
1	1	43018	OUTBOARD GREASE SEAL
2	4	90620	1/4"-20NC x 1" LG. HHCS, PLATED
3	2	90860	3/8"-16NC X 1" LG HHCS, PLATED
4	4	93005	1/4" SPLIT LOCKWASHER, PLATED
5	2	93024	3/8" SPLIT LW, PLTD.
6	1	107016-02	MOTOR ADAPTER
7	1	S-3673	SHAFT COUPLING, 1-1/8" X 3/4"
8	1	107030-02	STD. 3" PUMP HYDRAULIC MOTOR - .0072 GAL/REV
		107030-03	OPTIONAL LOW FLOW MOTOR - 0.0038 GAL/REV

HYDRAULIC MOTOR DETAILS:

COUNTER-CLOCKWISE (CCW) ROTATION
 SAE "A" 2-BOLT FLANGE
 3400 RPM MAX 3500 PSI MAX CONT.
 #16 O-RING INLET AND OUTLET PORTS
 3/4" DIAMETER x 1.94" LONG SHAFT
 "107030-02" STD. MOTOR: 0.0072 GAL/REV
 (APPROX. 25 GPM REQUIRED AT 3400 RPM)
 "107030-03" LOW FLOW MOTOR: 0.0038 GAL/REV
 (APPROX. 14 GPM REQUIRED AT 3400 RPM)

DIMENSIONAL INFORMATION

S-3220 (2" NPT PORTS)

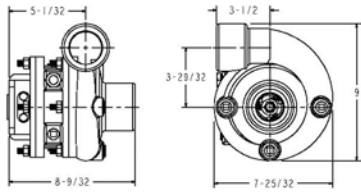

S-3320 (3" NPT PORTS)

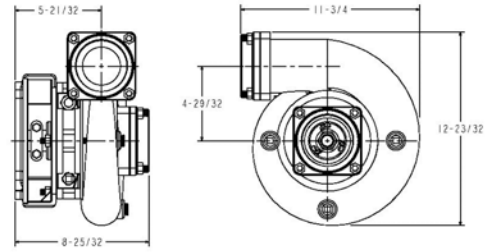

SP-3220 (2" NPT PORTS)

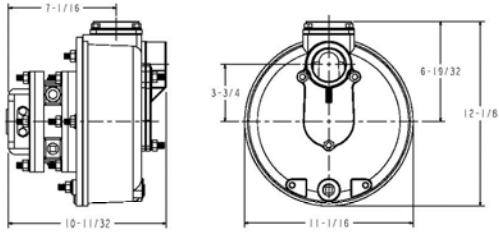

SP-3320 (3" NPT PORTS)

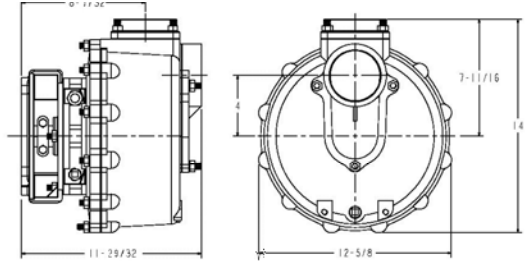

2" PEDESTAL

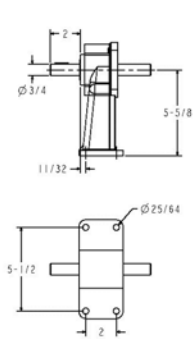

3" PEDESTAL

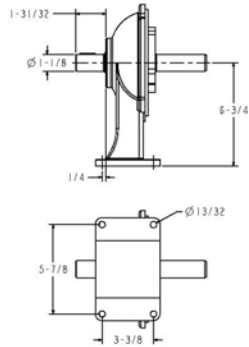

S-3325-P (3" NPT PORTS)

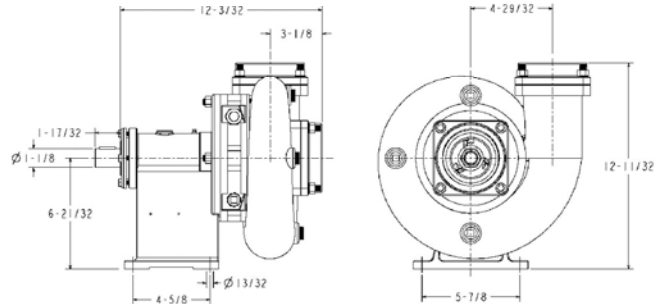

2" PUMP BASE DETAIL

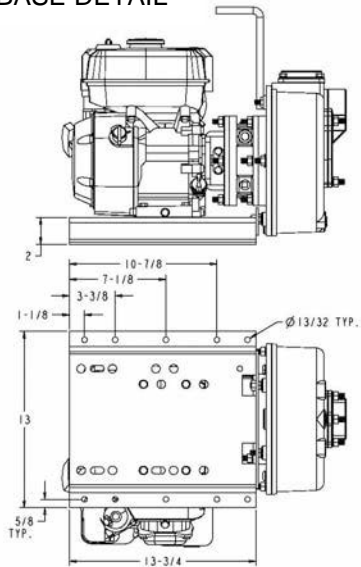

3" PUMP BASE DETAIL

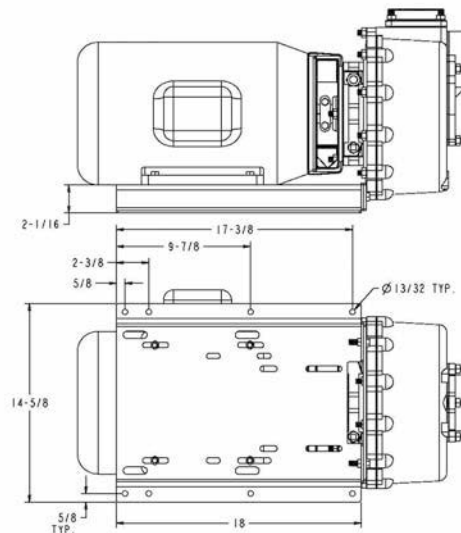

TROUBLE SHOOTING

ISSUE	PROBABLE CAUSE
Pump makes rattling noise while running	Cavitation or pump starvation (suction lift is too high or the inlet line is too restrictive)
Reduced pump output or pressure	Clogged impeller or inlet piping (including strainer)
	Leaks in suction line or at inlet gasket
	Collapsed suction line
	Trapped air in sections of suction line
	Suction lift is too great
	Discharge lift is too great
	Worn or damaged parts (impeller or casing)
Pump fails to prime or slow prime	Leaks in suction line or at inlet gasket
	Suction lift is too great
	Collapsed suction line
	Not enough water in casing to prime pump (self-priming)
Seal reservoir fluid changes level	Leak at the input shaft seal if level is low
	Leak at the impeller side seal if level is high
Pump makes screeching or metal on metal noises	Improper installation on motor, engine, or pedestal shaft The shaft (and impeller) have been forced into the pump and against the volute

NOTES

LIMITED WARRANTY

THIS WARRANTY IS IN LIEU OF ALL OTHER WRITTEN OR EXPRESS WARRANTIES AND REPRESENTATIONS. ANY IMPLIED WARRANTIES INCLUDING MERCHANTABILITY OR FITNESS FOR ANY PARTICULAR PURPOSE ARE EXPRESSLY LIMITED TO THIS WRITTEN WARRANTY. CDS-JOHN BLUE COMPANY SHALL NOT BE LIABLE FOR CONSEQUENTIAL DAMAGES.

Use of this product for any purpose other than its original intent, abuse of the product, and/or any modification to the original product is strictly prohibited by the manufacturer, CDS-John Blue Company. Any modification to the product should be approved by CDS-John Blue Company prior to use. CDS-John Blue Company will deny Warranty claims and liability in any situation involving misuse, abuse or modification.

Each new machine or component manufactured by CDS-John Blue Company through original buyer is warranted by CDS-John Blue Company to buyer and to any party or parties to whom buyer may resell, lease or lend the equipment to be free from defects in material and workmanship under normal use and service. This obligation of CDS-John Blue Company under this warranty is limited to the repair or replacement of defective parts or correction of improper workmanship of any parts of such equipment which shall within two years from the date of CDS-John Blue's original delivery thereof, be returned to CDS-John Blue's factory, transportation charges prepaid and which CDS-John Blue Company shall determine to its satisfaction upon examination thereof to have been thus defective. When it is impractical to return the defective parts of such equipment to CDS-John Blue's factory, then CDS-John Blue shall have no liability for the labor cost involved in repairing or replacing any such parts and shall be liable solely for supplying the material necessary to replace or repair the defective parts, provided that prior thereto CDS-John Blue Company shall have determined to its satisfaction that any such parts are thus defective.

This warranty shall not apply to any equipment which shall have been repaired or altered outside CDS-John Blue's factory in any way so as to affect its durability, nor which has been subjected to misuse, abuse, negligence or accident, or operated in any manner other than in accordance with operating instructions provided by CDS-John Blue Company. This warranty does not extend to repairs made necessary by the use of inferior or unsuitable parts or accessories, or parts or accessories not recommended by CDS-John Blue Company.

CDS-John Blue Company makes no warranties in respect to parts, accessories or components not manufactured by CDS-John Blue Company, same ordinarily being warranted separately by their respective manufacturers.

DIVISION OF ADVANCED SYSTEMS TECHNOLOGIES

HUNTSVILLE, AL (256) 721-9090



CDS-John Blue Company

Division of Advanced Systems Technology

165 Electronics Blvd, Huntsville, AL 35824

Telephone: (256) 721-9090 - Fax (256)-721-9091 - Toll Free 1-800-253-2583

www.cds-johnblue.com

YOUR LOCAL DEALER

