

# FILL-RITE®

## SERIES BD1200C / BD4200D DC FUEL TRANSFER PUMPS FOR BIODIESEL B21-B100

(Biodiesel must conform to ASTM D6751 Standard)

### Owner's Operation & Safety Manual



BD1210C (shown)



#### CAUTION

Not for use with Gasoline, Diesel Fuel or Biodiesel less than B21. Use the Fill-Rite® Series FR1200 and FR4200 pumps to dispense gasoline & diesel fuel.



#### SAFETY INSTRUCTIONS

To ensure safe and efficient operation, it is essential to read and follow each of these warnings and precautions.

1. Do NOT smoke near pump or use pump near an open flame. Fire could result.
2. Disconnect power to pump before servicing pump.
3. Take motors needing service to an authorized repair shop to maintain "explosion-proof" and "rain-proof" integrity.
4. A biodiesel compatible filter should be used on pump outlet to ensure that no foreign material is transferred to fuel tank.
5. The pump motor is equipped with thermal overload protection. If overheated, it will shut itself off without any damage to the windings. Move ON / OFF lever to the 'OFF' position to reset pump.
6. Tank or barrel should be anchored to prevent tipping in both the full and empty conditions.
7. To minimize static electricity build-up, keep nozzle in contact with container being filled while filling container.



#### DANGER



Electrical wiring should be done by a licensed electrician in compliance with local, state and national electrical code, ANSI/NFPA 70, 30, 30A as appropriate. Rigid conduit should be used and a proper ground must be provided to avoid the possibility of electrical shock. Failure to comply with this warning could result in serious injury and/or loss of property. Use only static wire, conductive hose when pumping flammable fluids.



#### WARNING

This product should not be used for fluid transfer into aircraft. This product is not suited for use with fluids for human consumption or fluids containing water.

#### GENERAL DESCRIPTION

The Fill-Rite Series BD1200C/BD4200D products are positive displacement, rotary vane pumps. Their rugged motors are explosion-proof and rain-proof to ensure a long life of dependability.

#### MECHANICAL INSTALLATION INSTRUCTIONS

Do **NOT** install additional foot valves or check valves unless they have a pressure relief valve.

1. Use Teflon® Tape on all pipe threads
2. Tightly screw suction pipe (21) into inlet flange (1) of pumping unit.
3. Extend suction pipe into tank or barrel to within 3" of tank bottom. Do not rest suction pipe on bottom of tank.
4. Screw inlet flange of pump into tank or barrel opening. Inlet flange must be completely and securely threaded into an undamaged tank or barrel bung.

#### ELECTRICAL INSTALLATION INSTRUCTIONS

1. Install pump as described in Mechanical Installation Instructions.  
**Read and understand all of the electrical wiring instructions before proceeding.**
2. Remove pump's electrical junction box cover and straighten the 2 wires to make the stripped wire ends accessible outside of the junction box.
3. Screw furnished cable connector into ½ inch NPT conduit opening in pump junction box.
4. Strip 6 inches of the outer covering from one end of the furnished electrical cable being careful not to damage the black and red wire insulation.
5. Loosen cable connector nut and pass the stripped end of the furnished cable through the cable connector until 2 inches of the unstripped cable is within the cable connector. Tighten the cable connector nut.
6. Strip ½ inch of the installation from the ends of the red and black cable wires. Using the furnished wire nuts, connect these wires to the pump wires matching the colors. Be sure no bare wire is exposed.
7. Fold wires into junction box and replace cover making sure the gasket is in place. Make sure all screws are seated so there is no space between the cover and the junction box.

#### For Vehicle Installation

Follow steps 1 through 7 above.

- A. Electrically ground the pump to the vehicle (fuel tank pump is mounted on must also be grounded). To electrically ground pump, remove green grounding screw located next to junction box cover. Insert this screw through eyelet of furnished green grounding wire assembly and refasten it securely to the pump. The other end of the wire is to be stripped of insulation and the bare wire securely bonded to the vehicle frame.

**CAUTION: Do not connect the positive or negative power to the green screw or wire as this could cause a fire.**

- B. Pass the electrical wires to the source of the vehical power system, supporting the wires as necessary and protecting them from sharp edges, heat and anything that could damage the wires and insulation.
- C. Attach one end of a 30 amp, slow-blow fuse holder to the **red** pump wire. Make a solid electrical connection with the other end

of the fuse holder to the **positive** side of the battery. Make a solid connection with the **black** pump wire to the **negative** battery terminal or the end of the negative battery cable.

**CAUTION: Do not attempt to power the pump from vehicle wiring thinner than 12 gage such as the cigarette lighter wire because these thin wires could overheat and cause a fire.**

- D. Check all connections to make sure they are connected per instructions and all electrical codes. Install the 30 amp, slow-blow fuse in the fuse holder. The installation is now complete.

**CAUTION: Do not connect the positive or negative power to the green screw or wire as this could cause a fire.**

- B. Pass the electrical wires to the power source, supporting the wires as necessary and protecting them from sharp edges, heat and anything that could damage the wires and insulation.
- C. Attach one end of a 30 amp, slow-blow fuse holder to the **red** pump wire. Make a solid electrical connection to the **positive** terminal of the power source with the other end of the fuse holder. Make a solid connection with the **black** pump wire to the **negative** terminal of the power source.

**CAUTION: Do not attempt to power the pump from vehicle wiring thinner than 12 gage such as the cigarette lighter wire because these thin wires could overheat and cause a fire.**

- D. Check all connections to make sure they are connected per instructions and all electrical codes. Install the 30 amp, slow-blow fuse in the fuse holder. The installation is now complete.

## For Skid Mounted or Mobile Tanks

Follow steps 1 through 7 on Page 1.

- A. Electrically ground the pump to the Tank. To electrically ground pump, remove green grounding screw located next to junction box cover. Insert this screw through eyelet of furnished green grounding wire assembly and refasten it securely to the pump. The other end of the wire is to be stripped of insulation and the bare wire securely bonded to the tank.

## TROUBLESHOOTING

### IF PUMP FAILS TO PRIME:

- Check suction line for leaks or obstructions.
- Check bypass valve for dirt. The poppet should slide freely.
- Check electrical connections. Pump will run backwards if the black and red wires are reversed.
- Open nozzle to allow air to be removed from the system

### LOW PUMPING CAPACITY:

- Strainer screen clogged.
- Bypass valve not seating properly
- Obstruction in suction lines.
- Make sure all 5 vanes slide easily in their slots.

### PUMP IS BOUND:

If the motor hums but will not start, the probable cause is a stuck rotor. Remove rotor cover and check rotor and vanes for dirt.

## BIODIESEL NOTES

**Definition:** Biodiesel is a clean burning fuel made from vegetable oil or animal fat that has been processed to meet the requirements of ASTM D6751 standard. Only biodiesel that meets the ASTM D6751 standard are to be used with Fill-Rite Series BD1200C and BD4200D pumps. Unprocessed or recycled vegetable oil are not biodiesel and are not to be used with the Fill-Rite Series BD1200C or BD4200D pumps.

Biodiesel can be used as a pure fuel, but is often blended with petroleum diesel fuel. When blended, the resulting fuel is known by the percentage of biodiesel in the blend; ie. a 20% biodiesel blend with 80% petroleum diesel is known as B20. Pure biodiesel is B100, also known as "Neat" biodiesel. Blends with 20% biodiesel or less (B1-B20) are generally treated like petroleum diesel fuel.

The Fill-Rite Series BD1200C and BD4200D Transfer Pumps are designed to handle biodiesel blends of B21–B100 (21%-100% biodiesel). Users who wish to dispense blends with lower concentrations of biodiesel (B1-B20) should use the Fill-Rite Series FR1200C or FR4200D fuel pumps.

**Temperature Limitations:** B100 (100% biodiesel) that meets ASTM D6751 has a "gel" point of 38°F (3.3°C). If B100 gets colder than 40°F (4.4°C), the Fill-Rite Series BD1200C and BD4200D Transfer Pumps may not operate properly due to the thickness of the fluid. In some situations, tank manufacturers may be able to supply tank and pipeline heaters that are safe to use and can keep the temperature of the B100 above 40°F.

**Cleaning Properties of Biodiesel:** Biodiesel has solvent properties that give it scrubbing and cleaning properties that tend to loosen rust, varnish, and dirt in storage tanks, piping, and equipment. The resulting debris can clog filters and screens, or damage equipment. It is important to understand this and take precautions to prevent problems when first using biodiesel.

**Shelf Life of Biodiesel:** It is recommended that biodiesel be used within 6 months for best performance. Microbial growth may occur if biodiesel is stored for longer periods.

For more information on biodiesel, go to [www.biodiesel.org](http://www.biodiesel.org).

## PARTS LIST

ITM NO.	PART NO.	DESCRIPTION	QTY
1	1200F6465	Inlet Flange	1
2	100F0760	Screen	1
3	100F0792	Inlet Gasket Flurocarbon	1
4	1200F2763	Bypass Valve Flurocarbon	1
5	1200G9290	Bypass Gasket Flurocarbon (-121)	1
6	1200F2770	Bypass Spring	1
7	1200F6464	Bypass Cap	1
8	1200F6721	1/4-20 x 3/4 HHCS	4
9	4200G9807	Vane, Carbon	5
10	1200G8881	Rotor	1
11	1200F6440	Rotor Key	1
12	1200F6435	Rotor Cover	1
13	1200F6538	Rotor Cover Gasket Flurocarbon (-138)	1
14	1200KTF6446	Seal Assembly	1
15	702F3400	3/4" Steel Elbow (BD1210)	1
	800F4400	1" Street Elbow (BD4210)	1

ITM NO.	PART NO.	DESCRIPTION	QTY
16	600F2220	Screw 5/16-18 x 5/8 HHCS	2
17	700F6673	Nozzle Cover	1
18	BDH0709	1" Manual Nozzle	1
18b	6F3095	3/4 x 1 Reducer Bushing	1
19	BDH0707	3/4" Automatic Nozzle	OPT
	BDH0708	1" Automatic Nozzle	OPT
20	BDH0659	3/4" x 12' (BD1210)	1
	BDH0660	1" x 12' (BD4210)	1
21	1200KTG9099	Suction Pipe Steel	1
33	1200R9067	18' Power Cable	1
34	1200G9038	Junction Box Gasket	1
35	1200G8999	Junction Box Cover	1
36	VP1400F8823	Screw #10-32 x 3/4 PHMS	4

For more information go to [www.fillrite.com](http://www.fillrite.com)

### Optional Bio Diesel Meter Kits

PART#	DESCRIPTION
BD807CMK	3/4" Meter with mechanical register for BD1210
BD901MK	1" Meter with mechanical register for BD4210

Date of Manufacture can be found on the motor nameplate.  
XX XX  
Week year

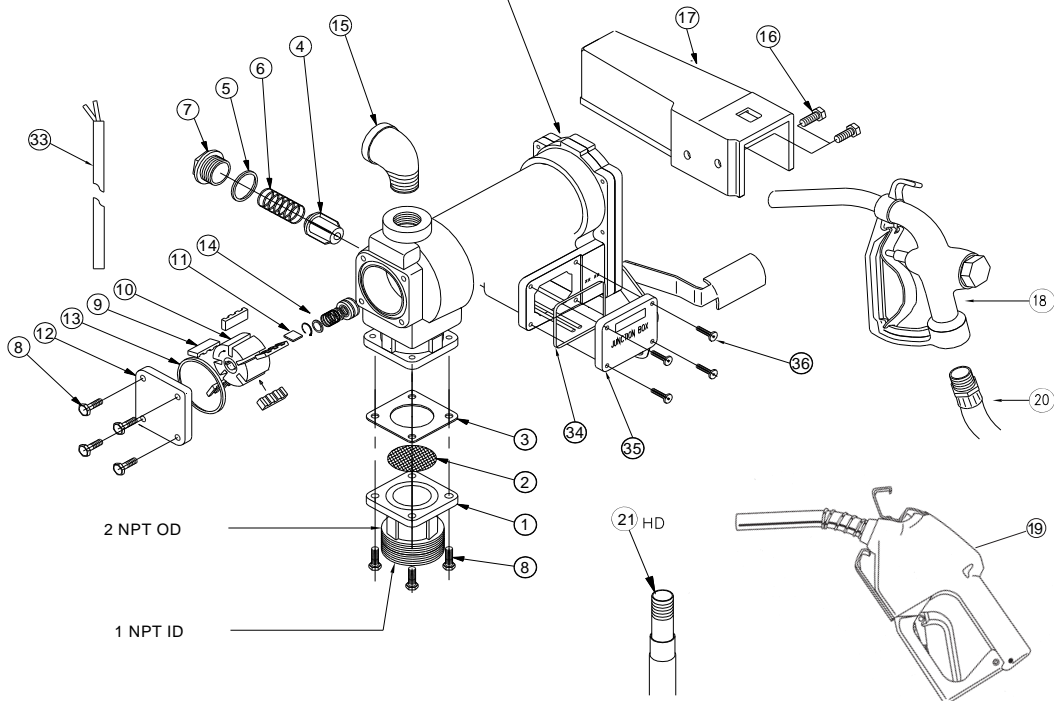

#### REPAIR KIT BD1210KTH0710

Includes Items  
2,3,4,5,6,9,10,11,12,13,14

# Heavy Duty

## Two Year Warranty

	BD1210C	BD4210D
Warranty	Two Years	Two Years
Motor HP	1/4 HP	1/4 HP
Motor Volt	12V DC	12V DC
Amp	25	30
Rainproof	yes	yes
	57 LPM	76 LPM
Flow with manual nozzle	15 GPM	20 GPM
Hose with static wire	3/4" x 12'	1" x 12'
Dimensions	12" wide 9" high 9" deep	13" wide 12" high 9" deep
Duty cycle	30 min.	30 min.
Max. Operating Temp	150°F	150°F
Min. Operating Temp	40°F*	40°F*
Minimum suction lift Bio Diesel B21-B100	6'	6'
Maximum outlet pressure	12 psi	14 psi
Minimum dry vacuum	5" mercury	5" mercury
Outlet	3/4" F NPT	1" F NPT
Threaded tank adapter	2" M NPT	2" M NPT
Inlet suction port	1" F NPT	1" F NPT
Thermal overload protection	yes	yes
Integral inlet screen	yes	yes
Motor UL and cUL listed	yes	yes
Ball Bearing construction	yes	yes
Security	Padlocking	Padlocking
Fluid Compatibility	Biodiesel B21-B100	Biodiesel B21-B100
* Bio Diesel B100 gel temperature is 38°F. (Bio Diesel that conforms to ASTM D6751 Standard)		

## PRODUCT WARRANTY

Tuthill Transfer Systems ("Manufacturer") warrants to each consumer buyer of its Fill-Rite products (the "Buyer"), from the date of invoice or sales receipt, that goods of its manufacture ("Goods") will be free from defects of material and workmanship. Duration of this warranty is as follows:

- Heavy Duty Products - Two years
- Standard Duty Products – One year
- Economy Duty Products – One year
- Cabinet pumps, Parts, and Accessories - One year

Manufacturer's sole obligation under the foregoing warranties will be limited to either, at Manufacturers' option, replacing or repairing defective Goods (subject to limitations hereinafter provided) or refunding the purchase price for such Goods theretofore paid by the Buyer, and Buyer's exclusive remedy for breach of any such warranties will be enforcement of such obligations of Manufacturer. If Manufacturer so requests the return of the Goods, the Goods will be redelivered to Manufacturer in accordance with Manufacturer's instructions F.O.B. Factory. The remedies contained herein shall

constitute the sole recourse of the Buyer against Manufacturer for breach of warranty. IN NO EVENT SHALL MANUFACTURER'S LIABILITY ON ANY CLAIM FOR DAMAGES ARISING OUT OF THE MANUFACTURE, SALE, DELIVERY, OR USE OF THE GOODS EXCEED THE PURCHASE PRICE OF THE GOODS. The foregoing warranties will not extend to Goods subjected to misuse, neglect, accident or improper installation or maintenance, or which have been altered or repaired by anyone other than Manufacturer or its authorized representative. THE FOREGOING WARRANTIES ARE EXCLUSIVE AND IN LIEU OF ALL OTHER WARRANTIES OF MERCHANTABILITY, FITNESS FOR PURPOSE OF ANY OTHER TYPE, WHETHER EXPRESS OR IMPLIED. No person may vary the foregoing warranties and remedies except in writing signed by a duly authorized officer of Manufacturer. Warranties or remedies that differ from the foregoing shall not otherwise be binding on Manufacturer. The Buyer's acceptance of delivery of the Goods constitutes acceptance of the foregoing warranties and remedies, and all conditions and limitations thereof.



**TUTHILL**  
Transfer Systems

8825 Aviation Drive  
Fort Wayne, Indiana USA 46809  
Tel 260 747-7524 Fax 260 747-3159

www.tuthill.com